

Evaluation Board for the **ADuM4136** iCoupler, Dual-Supply, High Voltage, Isolated IGBT Gate Driver

FEATURES

- 4 A peak drive output capability**
- Output power device resistance: <math><1 \Omega</math>**
- Desaturation protection**
 - Isolated fault output**
 - Soft shutdown on fault**
- Isolated fault and ready functions**
- Low propagation delay: <math><50 \text{ ns}</math>**
- Operating temperature range: -40°C to $+125^\circ\text{C}$**
- Output voltage range to 35 V**
- Output and input undervoltage lockout (UVLO)**
- Pad placement for multiple switch types**
- Screw terminals for easy connectivity**
- Jumpered enable/disable**

EVALUATION KIT CONTENTS

EVAL-ADuM4136EBZ evaluation board

EQUIPMENT NEEDED

Suggested test equipment

- Primary side power supply: 0 V to 6 V at 100 mA**
- Secondary side supply: 0 V to 35 V at 250 mA**
- Optional secondary supply: 0 V to 15 V at 250 mA**
- Square wave generator: 0 V to 5 V**

GENERAL DESCRIPTION

The **EVAL-ADuM4136EBZ** evaluation board supports the **ADuM4136** single-channel gate driver, which is specifically optimized for driving insulated gate bipolar transistors (IGBTs). Analog Devices, Inc., iCoupler® technology provides isolation between the input signal and the output gate driver.

The **ADuM4136** provides operation with voltages of up to 35 V. With a dual-rail supply, the negative rail can go as low as -15 V, providing robust turn off of the IGBT.

The **EVAL-ADuM4136EBZ** evaluation board facilitates testing of the desaturation circuitry with pads available for standard desaturation detection. The evaluation board has layout locations for three different types of discrete switches, allowing for a wide range of device testing. Screw terminals provide easy access to supplying the secondary side with either a single or dual supply.

For complete information about the **ADuM4136**, refer to the product data sheet that should be consulted in conjunction with this user guide when using the evaluation board.

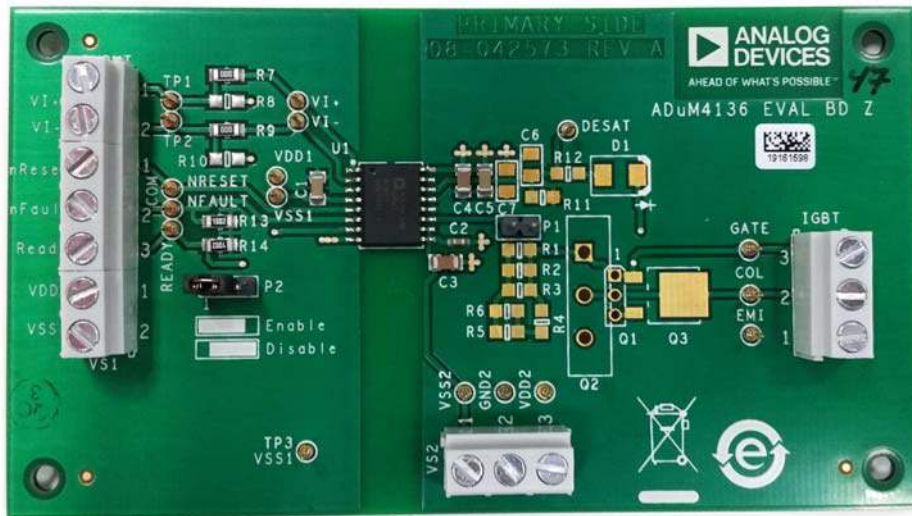

Figure 1. Picture of the **EVAL-ADuM4136EBZ** in Stock Configuration

TABLE OF CONTENTS

Features	1	Initial Configuration	3
Evaluation Kit Contents.....	1	Pad Layout for the Device Under Test (DUT).....	3
Equipment Needed.....	1	Power Connections	3
General Description	1	Input/Output Connections	3
Revision History	2	Bill of Materials.....	4
Setting Up the EVAL-ADuM4136EBZ.....	3		

REVISION HISTORY

7/2016—Revision 0: Initial Version

SETTING UP THE EVAL-ADUM4136EBZ INITIAL CONFIGURATION

Before the first use, certain steps must be completed to prepare the board for operation. In the stock configuration, the R1 to R6 resistors are not placed. These are the locations of the series external resistors for the charging and discharging paths to V_{OUT_ON} and V_{OUT_OFF} . It is recommended to use 1206 surface-mount resistors with values between approximately $1\ \Omega$ and $10\ \Omega$, depending on the load being driven. An actual IGBT or MOSFET can be placed in the provided landing patterns to the right of P1. P1 allows shorting across the series external resistors to observe overshoot and/or allow the user to probe voltage to quantify peak currents.

In the stock configuration, the desaturation circuitry is left open. Before the first use, if desaturation functionality is not used, it is recommended to short the DESAT pin to ground, either by a wire or by placing a $0\ \Omega$ resistor in the C6 component pad. Failure to do so results in a desaturation fault being observed on the first rising edge of the output.

If the desaturation circuitry is tested, an IGBT or MOSFET must be added to the circuit to allow for the DESAT pin to be pulled down during on times, preventing the desaturation fault. Additionally, C6 (C_{BLANK}), R12 (R_{BLANK}), and D1 must have the appropriate components placed. For details about sizing, refer to the ADuM4136 data sheet. R11 is provided to allow extra DESAT pin blanking current by means of an external pull-up resistor. C7 can provide decoupling for this external pull-up current source, if desired.

R13 and R14 come with $10\ k\Omega$ resistors in place. These resistors provide pull-ups to the READY and FAULT pins. P2 allows for easy enabling and disabling of the device by means of jumper pins. A silkscreen reminder is included to show which pins to short to enable or disable the device. R8 and R10 allow for easy placement of $50\ \Omega$ terminating resistors, if desired.

Pins accompany the screw terminals. The user can decide which connection mechanism to use. Do not leave VSS2 floating. It must always be at or less than the potential of GND2. Shorting VSS2 and GND2 is a valid operating point.

During operation, if a fault is seen, the \overline{FAULT} pin is brought low. In this case, the device can be reset by either powering down VDD1 to GND1 and powering back up, or by bringing the \overline{RESET} pin low then high again. The easiest way to toggle \overline{RESET} is to remove the jumper on P3 from Pin 2 and Pin 3 and then replace it. An internal pull-down resistor brings \overline{RESET} low on its own.

PAD LAYOUT FOR THE DEVICE UNDER TEST (DUT)

Figure 4 shows the top layer artwork for the dual-gate driver circuit.

- U1 is the footprint for the ADuM4136.
- C1, C2, and C5 are $0.1\ \mu\text{F}$ bypass capacitors; C3 and C4 are $10\ \mu\text{F}$ bypass capacitors. C7 is provided as an extra space in

case more decoupling is desired. C6 allows for a desaturation blanking capacitor to be placed.

- Q1, Q2, and Q3 can be populated with TO-252 MOSFETs or IGBTs with the pinout shown in Figure 2.
- R1 to R6 are gate resistors that control the edges of the outputs. By default, no resistors are installed; these resistors must be populated with low value 1206 resistors, generally in the $1\ \Omega$ to $10\ \Omega$ range.

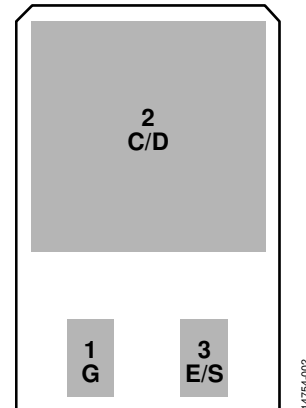

Figure 2. IGBT/MOSFET Footprint

POWER CONNECTIONS

Follow these steps to connect the ADuM4136 evaluation board to the power supply:

1. Connect the 5 V or 3.3 V input supply with the positive terminal on VDD1 and the ground on VSS1.
2. Connect the ADuM4136 VDD2 supply voltage (12 V to 35 V) to the VDD2 pin and its return to the VSS2 pin.

VSS1 and VSS2 are functionally isolated. The emitter/source of the IGBT/MOSFET is tied to GND2.

INPUT/OUTPUT CONNECTIONS

The VI+ and VI− pins are complementary metal oxide semiconductor (CMOS) inputs. R8 and R10 are provided in case the user needs to terminate the inputs with a $50\ \Omega$ load.

R7 and R9 are provided to add damping, if needed. However, in most cases, the $0\ \Omega$ resistors in the stock configuration can remain on R7 and R9.

The ADuM4136 evaluation board comes with screw terminals for both the input and output connections. These terminals are to facilitate connection options but are not the best option for high performance transient testing. The best measurements performed on the load, whether it is an IGBT or MOSFET or a load capacitor, come from small loop measurements performed right at the load. Using the screw terminals as either the sensing node or for the connection of the load often results in overshoot being observed during measurement.

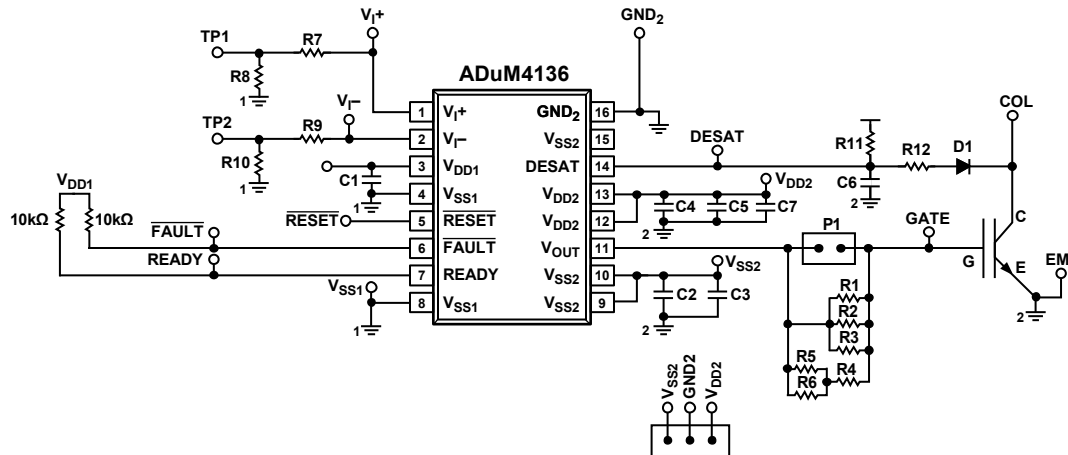

Figure 3. Schematic of the EVAL-ADuM4136EBZ

14754-003

BILL OF MATERIALS

Table 1. Bill of Materials for Stock Board

Reference	Part
R13, R14	Resistor, 10 kΩ, 1206
R7, R9	Resistor, 0 Ω, 1206
U1	ADuM4136
C1, C5	Capacitor, 0.1 μF, 25 V, 10%, 1206
C3, C4	Capacitor, 10 μF, 50 V, 10%, 1206
C2	Capacitor, 0.1 μF, 25 V, 10%, 0402
R1 to R6, R11, R12, C6, C7, D1, R8, R10	Not installed

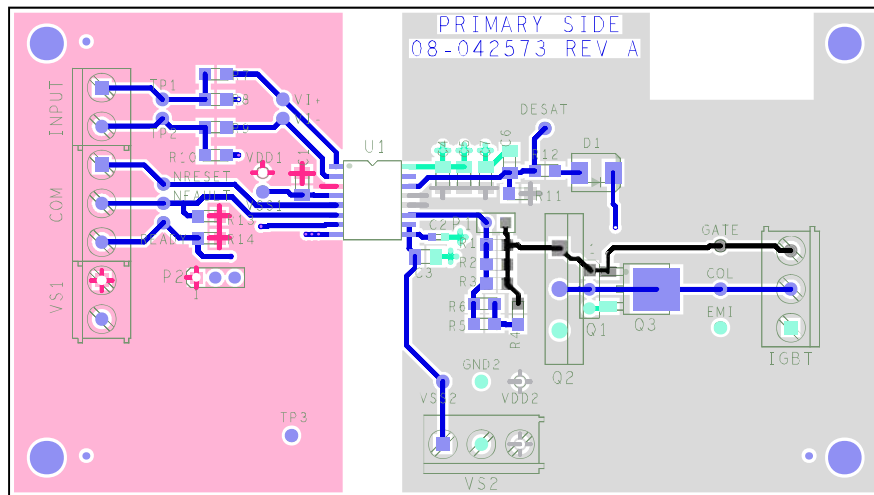

Figure 4. EVAL-ADuM4136EBZ Evaluation Board Top Layer

14754-004

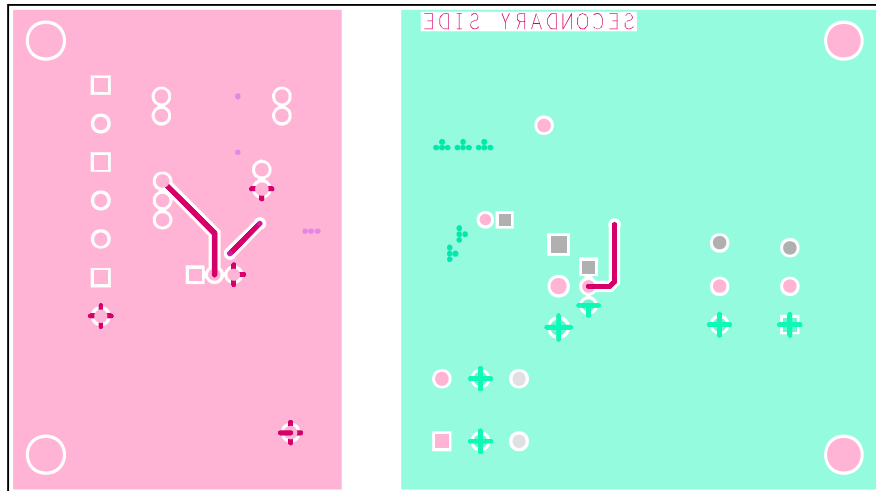

Figure 5. EVAL-ADuM4136EBZ Evaluation Board Bottom Layer



ESD Caution

ESD (electrostatic discharge) sensitive device. Charged devices and circuit boards can discharge without detection. Although this product features patented or proprietary protection circuitry, damage may occur on devices subjected to high energy ESD. Therefore, proper ESD precautions should be taken to avoid performance degradation or loss of functionality.

Legal Terms and Conditions

By using the evaluation board discussed herein (together with any tools, components documentation or support materials, the "Evaluation Board"), you are agreeing to be bound by the terms and conditions set forth below ("Agreement") unless you have purchased the Evaluation Board, in which case the Analog Devices Standard Terms and Conditions of Sale shall govern. Do not use the Evaluation Board until you have read and agreed to the Agreement. Your use of the Evaluation Board shall signify your acceptance of the Agreement. This Agreement is made by and between you ("Customer") and Analog Devices, Inc. ("ADI"), with its principal place of business at One Technology Way, Norwood, MA 02062, USA. Subject to the terms and conditions of the Agreement, ADI hereby grants to Customer a free, limited, personal, temporary, non-exclusive, non-sublicensable, non-transferable license to use the Evaluation Board FOR EVALUATION PURPOSES ONLY. Customer understands and agrees that the Evaluation Board is provided for the sole and exclusive purpose referenced above, and agrees not to use the Evaluation Board for any other purpose. Furthermore, the license granted is expressly made subject to the following additional limitations: Customer shall not (i) rent, lease, display, sell, transfer, assign, sublicense, or distribute the Evaluation Board; and (ii) permit any Third Party to access the Evaluation Board. As used herein, the term "Third Party" includes any entity other than ADI, Customer, their employees, affiliates and in-house consultants. The Evaluation Board is NOT sold to Customer; all rights not expressly granted herein, including ownership of the Evaluation Board, are reserved by ADI. CONFIDENTIALITY. This Agreement and the Evaluation Board shall all be considered the confidential and proprietary information of ADI. Customer may not disclose or transfer any portion of the Evaluation Board to any other party for any reason. Upon discontinuation of use of the Evaluation Board or termination of this Agreement, Customer agrees to promptly return the Evaluation Board to ADI. ADDITIONAL RESTRICTIONS. Customer may not disassemble, decompile or reverse engineer chips on the Evaluation Board. Customer shall inform ADI of any occurred damages or any modifications or alterations it makes to the Evaluation Board, including but not limited to soldering or any other activity that affects the material content of the Evaluation Board. Modifications to the Evaluation Board must comply with applicable law, including but not limited to the RoHS Directive. TERMINATION. ADI may terminate this Agreement at any time upon giving written notice to Customer. Customer agrees to return to ADI the Evaluation Board at that time. LIMITATION OF LIABILITY. THE EVALUATION BOARD PROVIDED HEREUNDER IS PROVIDED "AS IS" AND ADI MAKES NO WARRANTIES OR REPRESENTATIONS OF ANY KIND WITH RESPECT TO IT. ADI SPECIFICALLY DISCLAIMS ANY REPRESENTATIONS, ENDORSEMENTS, GUARANTEES, OR WARRANTIES, EXPRESS OR IMPLIED, RELATED TO THE EVALUATION BOARD INCLUDING, BUT NOT LIMITED TO, THE IMPLIED WARRANTY OF MERCHANTABILITY, TITLE, FITNESS FOR A PARTICULAR PURPOSE OR NON-INFRINGEMENT OF INTELLECTUAL PROPERTY RIGHTS. IN NO EVENT WILL ADI AND ITS LICENSORS BE LIABLE FOR ANY INCIDENTAL, SPECIAL, INDIRECT, OR CONSEQUENTIAL DAMAGES RESULTING FROM CUSTOMER'S POSSESSION OR USE OF THE EVALUATION BOARD, INCLUDING BUT NOT LIMITED TO LOST PROFITS, DELAY COSTS, LABOR COSTS OR LOSS OF GOODWILL. ADI'S TOTAL LIABILITY FROM ANY AND ALL CAUSES SHALL BE LIMITED TO THE AMOUNT OF ONE HUNDRED US DOLLARS (\$100.00). EXPORT. Customer agrees that it will not directly or indirectly export the Evaluation Board to another country, and that it will comply with all applicable United States federal laws and regulations relating to exports. GOVERNING LAW. This Agreement shall be governed by and construed in accordance with the substantive laws of the Commonwealth of Massachusetts (excluding conflict of law rules). Any legal action regarding this Agreement will be heard in the state or federal courts having jurisdiction in Suffolk County, Massachusetts, and Customer hereby submits to the personal jurisdiction and venue of such courts. The United Nations Convention on Contracts for the International Sale of Goods shall not apply to this Agreement and is expressly disclaimed.