



力元電子（香港）有限公司

OLED 显示屏说明书

型号：LY190-128064

地址：深圳市南山區南光路 126 號鵬都大廈 B 座 1504

電話：0755-26523608

傳真：0755-86368541

郵編：518052

郵箱：jack@liyuan-elec.com

網址：www.liyuan-elec.com

PRODUCT SPECIFICATION

CONTENT

REVISION RECORD	3
1 OVERVIEW	4
2 FEATURES.....	4
3 MECHANICAL DATA	4
4 MECHANICAL DRAWING	5
5 MODULE INTERFACE.....	6
6 FUNCTION BLOCK DIAGRAM.....	7
6.1 FUNCTION BLOCK DIAGRAM.....	7
6.2 PANEL LAYOUT DIAGRAM.....	7
7 ABSOLUTE MAXIMUM RATINGS.....	8
8 ELECTRICAL CHARACTERISTICS.....	8
8.1 DC ELECTRICAL CHARACTERISTICS	8
8.2 ELECTRO-OPTICAL CHARACTERISTICS	9
8.3 AC ELECTRICAL CHARACTERISTICS	10
9 FUNCTIONAL SPECIFICATION AND APPLICATION CIRCUIT.....	14
9.1 POWER ON AND POWER OFF SEQUENCE.....	14
9.2 APPLICATION CIRCUIT.....	15
9.3 DISPLAY CONTROL INSTRUCTION.....	16
9.4 RECOMMENDED SOFTWARE INITIALIZATION	16
10 PACKAGE SPECIFICATION.....	17
11 RELIABILITY	18
11.1 RELIABILITY TEST.....	18
11.2 LIFETIME.....	18
11.3 FAILURE CHECK STANDARD.....	18
12 ILLUSTRATION OF OLED PRODUCT NAME	19
13 OUTGOING QUALITY CONTROL SPECIFICATIONS.....	20
13.1 SAMPLING METHOD	20
13.2 INSPECTION CONDITIONS	20
13.3 QUALITY ASSURANCE ZONES.....	20
13.4 INSPECTION STANDARD.....	21
14 PRECAUTIONS FOR OPERATION AND STORAGE.....	23
14.1 PRECAUTIONS FOR OPERATION	23
14.2 SOLDERING	24
14.3 PRECAUTIONS FOR STORAGE.....	24

PRODUCT SPECIFICATION

1 Overview

LY190-128064 is an OLED monochrome 128×64 dot matrix display module. The characteristics of this display module are high brightness, self-emission, high contrast ratio, slim/thin outline, wide viewing angle, wide temperature range, and low power consumption.

2 Features

- Display Color: White
- Dot Matrix:128×64
- Driver IC: SSD1308Z
- Interface:8-bit 8080,8-bit 6800, 4-wire SPI, I²C
- Wide range of operating temperature: -20℃~70℃

3 Mechanical Data

NO.	ITEM	SPECIFICATION	UNIT
1	Dot Matrix	128(W)×64(H)	-
2	Dot Size	0.15(W)×0.15 (H)	mm ²
3	Dot Pitch	0.17(W)×0.175 (H)	mm ²
4	Aperture Rate	76	%
5	Active Area	21.74(W)×11.175 (H)	mm ²
6	Panel Size	26.7(W)×19.26(H)	mm ²
7	Module Size	According to the annexed mechanical drawing	mm ³
8	Diagonal A/A Size	0.96	inch
9	Module Weight	1.33 ± 10%	gram

PRODUCT SPECIFICATION

4 Mechanical Drawing

如本印章非红色, 则表明该文件为非受控版本, 不会受到控制和更新. 请使用受控文件.
分发号: _____

受控章

Rev.	Date	Note
1	2009.02.25	Primary
2		

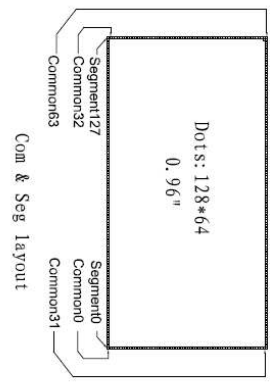
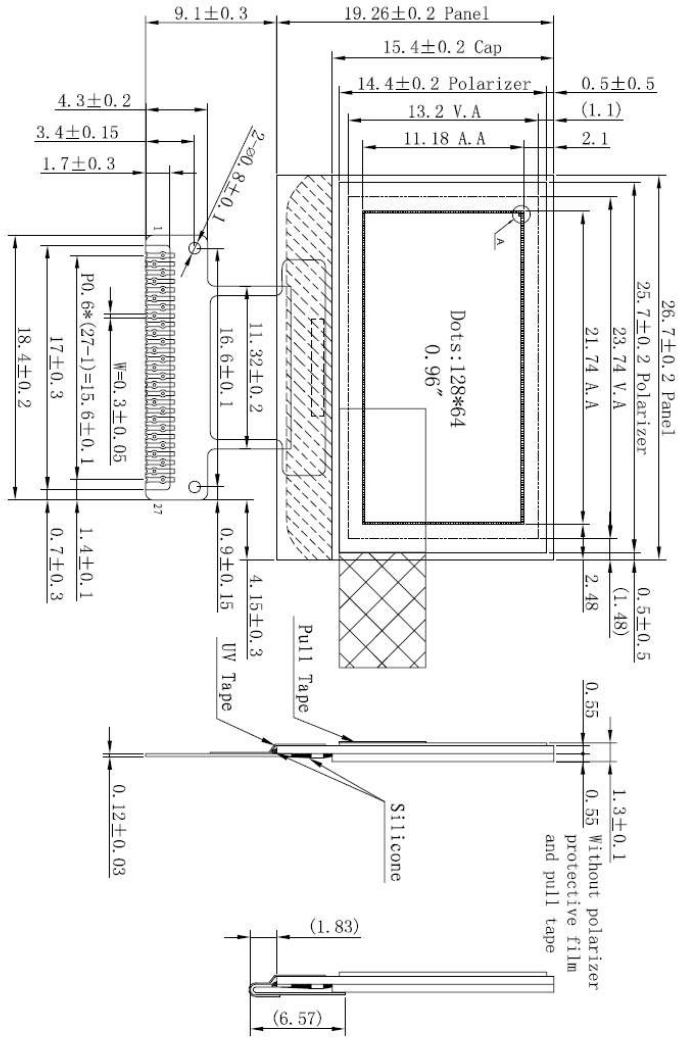

NO.	Pin Assignment	SYMBOL
1	NC	NC
2	VSS	VSS
3	NC	NC
4	NC	NC
5	NC	NC
6	NC	NC
7	NC	NC
8	VDD	VDD
9	BS1	BS1
10	BS2	BS2
11	CS#	CS#
12	RES#	RES#
13	D/C#	D/C#
14	R/W#	R/W#
15	E	E
16	VCOMH	VCOMH
17	VCC	VCC
18	D0	D0
19	D1	D1
20	D2	D2
21	D3	D3
22	D4	D4
23	D5	D5
24	D6	D6
25	D7	D7
26	IRRF	IRRF
27	NC	NC

- Specification
1. Display: OLED(White)
 2. Format: 128*64
 3. Driver IC: SSD1308Z
 4. General Tolerance: ± 0.3
 5. Operate temp.: $-20^{\circ}\text{C} \sim 70^{\circ}\text{C}$
 6. Storage temp.: $-30^{\circ}\text{C} \sim 80^{\circ}\text{C}$
 7. Duty: 1/64

Customer Approval	Part Name	Module Ass'y	Date	Rev	Unit	Sheet
Signature	00190	00190-MA1-A	2009.02.25	A	mm	1/1
	Project Code		DES' D BY	CHK' D BY	CHK' D BY	APPROVED
	Part No.					

PRODUCT SPECIFICATION

5 Module Interface

PIN NO.	PIN NAME	DESCRIPTION																																																													
1	NC	No Connection.																																																													
2	VSS	Ground.																																																													
3~7	NC	No Connection.																																																													
8	VDD	Power supply pin for core logic operation.																																																													
9	BS1	MCU bus interface selection pins.																																																													
10	BS2	<table border="1" style="width: 100%; border-collapse: collapse;"> <thead> <tr> <th>SSD1308 Pin Name</th> <th>I²C Interface</th> <th>6800-parallel interface (8 bit)</th> <th>8080-parallel interface (8 bit)</th> <th>4-wire Serial interface</th> </tr> </thead> <tbody> <tr> <td>BS1</td> <td>1</td> <td>0</td> <td>1</td> <td>0</td> </tr> <tr> <td>BS2</td> <td>0</td> <td>1</td> <td>1</td> <td>0</td> </tr> </tbody> </table>	SSD1308 Pin Name	I ² C Interface	6800-parallel interface (8 bit)	8080-parallel interface (8 bit)	4-wire Serial interface	BS1	1	0	1	0	BS2	0	1	1	0																																														
SSD1308 Pin Name	I ² C Interface	6800-parallel interface (8 bit)	8080-parallel interface (8 bit)	4-wire Serial interface																																																											
BS1	1	0	1	0																																																											
BS2	0	1	1	0																																																											
11	CS#	Chip Select, active low.																																																													
12	RES#	Reset, active low.																																																													
13	D/C#	H:Data; L :Command.																																																													
14	R/W#	6800: Read or Write ; 8080: Write; SPI or I ² C:connected to VSS.																																																													
15	E(/RD)	6800: Enable (E); 8080:Read; SPI or I ² C:connected to VSS.																																																													
16	VCOMH	Common signal deselected voltage level.Connected a capacitor to VSS.																																																													
17	VCC	Power supply for panel driving voltage.																																																													
18~25	D0~D7	<p>Data bus.</p> <table border="1" style="width: 100%; border-collapse: collapse;"> <thead> <tr> <th rowspan="2">Pin Name</th> <th colspan="9">Data/Command Interface</th> </tr> <tr> <th>D7</th> <th>D6</th> <th>D5</th> <th>D4</th> <th>D3</th> <th>D2</th> <th>D1</th> <th>D0</th> <th></th> </tr> </thead> <tbody> <tr> <td>8-bit 8080</td> <td colspan="9">D[7:0]</td> </tr> <tr> <td>8-bit 6800</td> <td colspan="9">D[7:0]</td> </tr> <tr> <td>4-wire SPI</td> <td colspan="5">Tie LOW</td> <td>NC</td> <td>SDIN</td> <td>SCLK</td> <td></td> <td></td> </tr> <tr> <td>I²C</td> <td colspan="5">Tie LOW</td> <td>SDA_{OUT}</td> <td>SDA_{IN}</td> <td>SCL</td> <td></td> <td></td> </tr> </tbody> </table>	Pin Name	Data/Command Interface									D7	D6	D5	D4	D3	D2	D1	D0		8-bit 8080	D[7:0]									8-bit 6800	D[7:0]									4-wire SPI	Tie LOW					NC	SDIN	SCLK			I ² C	Tie LOW					SDA _{OUT}	SDA _{IN}	SCL		
Pin Name	Data/Command Interface																																																														
	D7	D6	D5	D4	D3	D2	D1	D0																																																							
8-bit 8080	D[7:0]																																																														
8-bit 6800	D[7:0]																																																														
4-wire SPI	Tie LOW					NC	SDIN	SCLK																																																							
I ² C	Tie LOW					SDA _{OUT}	SDA _{IN}	SCL																																																							
26	IREF	Segment output current reference pin.Connected a resistor to VSS.																																																													
27	NC	No Connection.																																																													

6 Function Block Diagram

6.1 Function Block Diagram

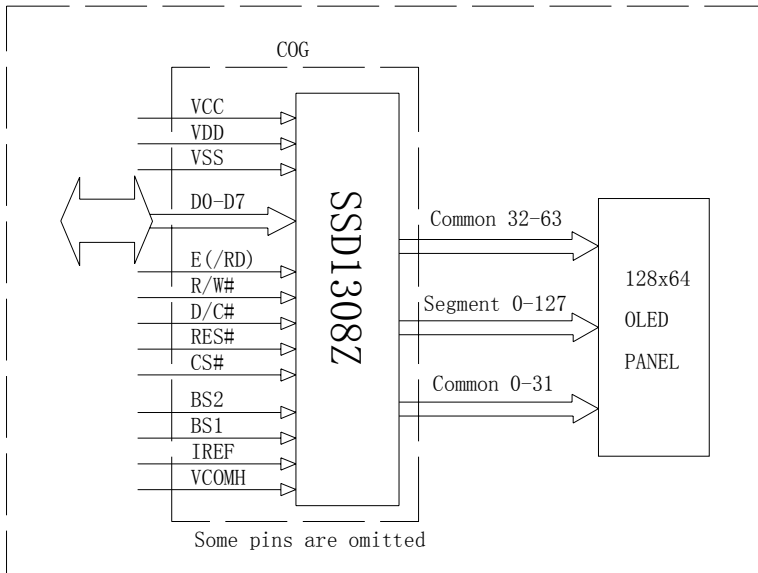

6.2 Panel Layout Diagram

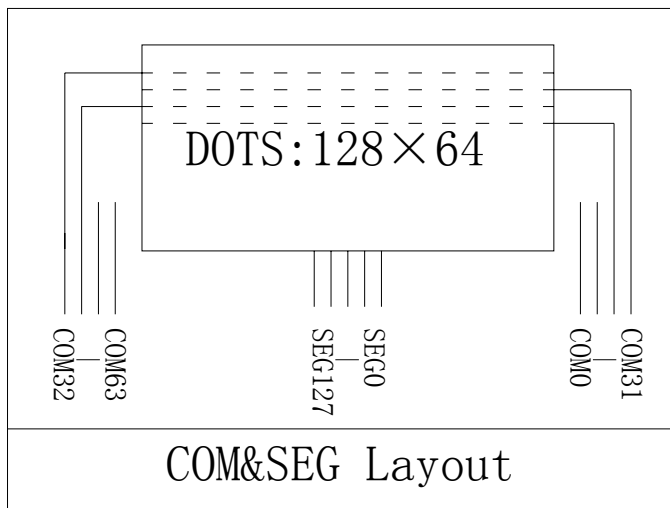

PRODUCT SPECIFICATION

7 Absolute Maximum Ratings

ITEM	SYMBOL	MIN	MAX	UNIT	REMARK
Logic supply voltage	V _{DD}	-0.3	4	V	IC maximum rating
OLED Operating voltage	V _{CC}	0	16	V	IC maximum rating
Operating Temp.	Top	-20	70	°C	-
Storage Temp	Tstg	-30	80	°C	-

Note (1): All of the voltages are on the basis of “VSS = 0V”.

Note (2): Permanent breakage of module may occur if the module is used beyond the maximum rating. The module can be normal operated under the conditions according to Section 8 “Electrical Characteristics”. Malfunctioning of the module may occur and the reliability of the module may deteriorate if the module is used beyond the conditions.

8 Electrical Characteristics

8.1 DC Electrical Characteristics

ITEM	SYMBOL	TEST CONDITION	MIN	TYPE	MAX	UNIT
Logic Supply Voltage	V _{DD}	22±3°C, 55±15%R.H	1.65	3	3.3	V
OLED Driver Supply Voltage	V _{CC}	22±3°C, 55±15%R.H	11.5	12	12.5	V
High-level Input Voltage	V _{IH}	-	0.8×V _{DD}	-	-	V
Low-level Input Voltage	V _{IL}	-	0	-	0.2×V _{DD}	V
High-level Output Voltage	V _{OH}	-	0.9×V _{DD}	-	-	V
Low-level Output Voltage	V _{OL}	-	0	-	0.1×V _{DD}	V

Note : The V_{CC} input must be kept in a stable value; ripple and noise are not allowed.

PRODUCT SPECIFICATION

8.2 Electro-optical Characteristics

ITEM	SYMBOL	TEST CONDITION	MIN	TYPE	MAX	UNIT
Normal Mode Brightness	L _{br}	All pixels ON(1)	80	100	-	cd/m ²
Standby Mode Brightness		Standby Mode 10% pixels ON(2)	-	25	-	cd/m ²
Normal Mode Power Consumption	Pt	All pixels ON(1)	-	96	120	mW
Standby Mode Power Consumption		Standby Mode 10% pixels ON(2)	-	7.2	-	mW
C.I.E(White)	(x)	x,y(CIE1931)	0.26	0.30	0.34	-
	(y)		0.28	0.32	0.36	-
Dark Room Contrast	CR	-	≥2000:1	-	-	-
Response Time	-	-	-	10	-	μ s
View Angle	-	-	≥160	-	-	Degree

Note(1): Normal Mode test conditions are as follows:

- Driving voltage :12V
- Contrast setting : 0x50
- Frame rate : 107Hz
- Duty setting : 1/64

Note(2): Standby Mode test conditions are as follows:

- Driving voltage : 12V
 - Contrast setting : 0x00
 - Frame rate : 107Hz
 - Duty setting : 1/64
-

PRODUCT SPECIFICATION

8.3 AC Electrical Characteristics

(1)6800-Series MPU Parallel Interface Timing Characteristics

(VDD - VSS = 1.65V to 3.3V, TA = 25°C)

Symbol	Parameter	Min	Typ	Max	Unit
t_{cycle}	Clock Cycle Time	300	-	-	ns
t_{AS}	Address Setup Time	0	-	-	ns
t_{AH}	Address Hold Time	0	-	-	ns
t_{DSW}	Write Data Setup Time	40	-	-	ns
t_{DHW}	Write Data Hold Time	7	-	-	ns
t_{DHR}	Read Data Hold Time	20	-	-	ns
t_{OH}	Output Disable Time	-	-	70	ns
t_{ACC}	Access Time	-	-	140	ns
PW_{CSL}	Chip Select Low Pulse Width (read)	120	-	-	ns
	Chip Select Low Pulse Width (write)	60	-	-	ns
PW_{CSH}	Chip Select High Pulse Width (read)	60	-	-	ns
	Chip Select High Pulse Width (write)	60	-	-	ns
t_{R}	Rise Time	-	-	40	ns
t_{F}	Fall Time	-	-	40	ns

6800-series MCU parallel interface characteristics

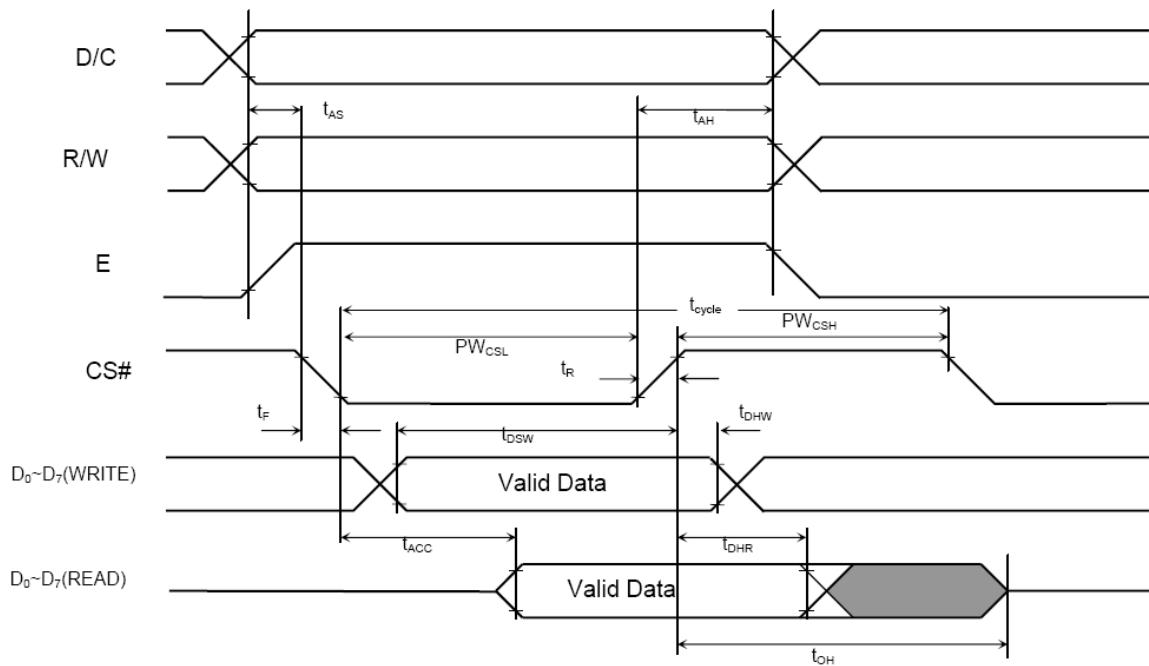

PRODUCT SPECIFICATION

(2)8080-Series MPU Parallel Interface Timing Characteristics

(VDD - VSS = 1.65V to 3.3V, TA = 25°C)

Symbol	Parameter	Min	Typ	Max	Unit
t_{cycle}	Clock Cycle Time	300	-	-	ns
t_{AS}	Address Setup Time	10	-	-	ns
t_{AH}	Address Hold Time	0	-	-	ns
t_{DSW}	Write Data Setup Time	40	-	-	ns
t_{DHW}	Write Data Hold Time	7	-	-	ns
t_{DHR}	Read Data Hold Time	20	-	-	ns
t_{OH}	Output Disable Time	-	-	70	ns
t_{ACC}	Access Time	-	-	140	ns
t_{PWLr}	Read Low Time	120	-	-	ns
t_{PWLw}	Write Low Time	60	-	-	ns
t_{PWHr}	Read High Time	60	-	-	ns
t_{PWHw}	Write High Time	60	-	-	ns
t_R	Rise Time	-	-	40	ns
t_F	Fall Time	-	-	40	ns
t_{CS}	Chip select setup time	0	-	-	ns
t_{CSH}	Chip select hold time to read signal	0	-	-	ns
t_{CSF}	Chip select hold time	20	-	-	ns

8080-series parallel interface characteristics

Write Cycle

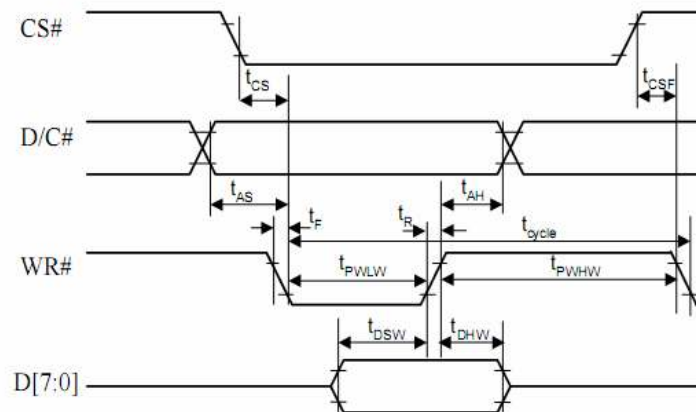

Read cycle

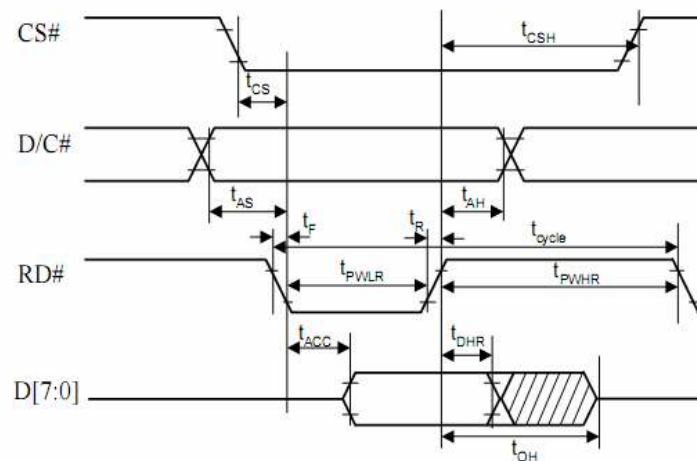

PRODUCT SPECIFICATION

(3)4-wire Serial Interface Timing Characteristics

(VDD - VSS = 1.65V to 3.3V, TA = 25°C)

Symbol	Parameter	Min	Typ	Max	Unit
t_{cycle}	Clock Cycle Time	100	-	-	ns
t_{AS}	Address Setup Time	15	-	-	ns
t_{AH}	Address Hold Time	15	-	-	ns
t_{CSS}	Chip Select Setup Time	20	-	-	ns
t_{CSH}	Chip Select Hold Time	10	-	-	ns
t_{DSW}	Write Data Setup Time	15	-	-	ns </td
t_{DHW}	Write Data Hold Time	15	-	-	ns
t_{CLKL}	Clock Low Time	20	-	-	ns
t_{CLKH}	Clock High Time	20	-	-	ns
t_{R}	Rise Time	-	-	40	ns
t_{F}	Fall Time	-	-	40	ns

4-wire Serial interface characteristics

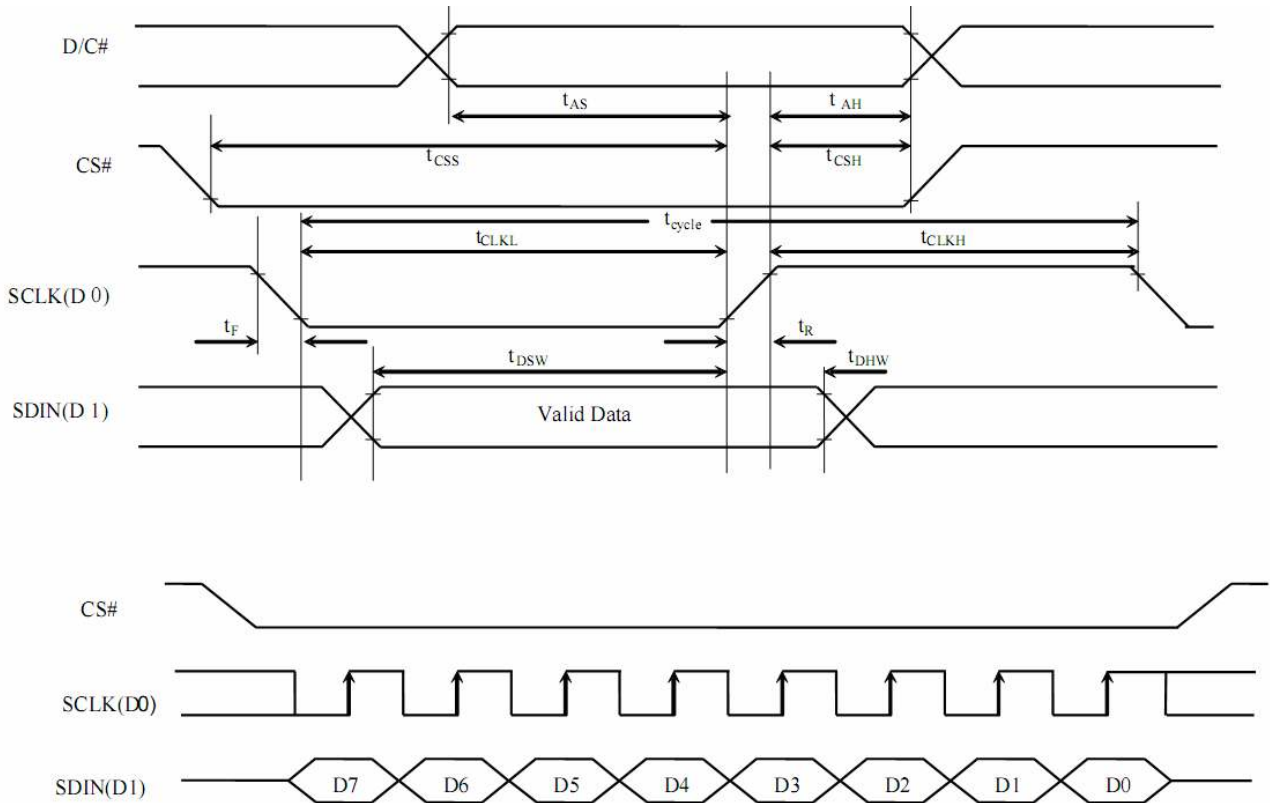

PRODUCT SPECIFICATION

(4) I²C interface Timing Characteristics

(VDD - VSS = 1.65V to 3.3V, TA = 25°C)

Symbol	Parameter	Min	Typ	Max	Unit
t_{cycle}	Clock Cycle Time	2.5	-	-	us
t_{HSTART}	Start condition Hold Time	0.6	-	-	us
t_{HD}	Data Hold Time (for “SDA _{OUT} ” pin)	0	-	-	ns
	Data Hold Time (for “SDA _{IN} ” pin)	300	-	-	ns
t_{SD}	Data Setup Time	100	-	-	ns
t_{SSTART}	Start condition Setup Time (Only relevant for a repeated Start condition)	0.6	-	-	us
t_{SSTOP}	Stop condition Setup Time	0.6	-	-	us
t_{R}	Rise Time for data and clock pin	-	-	300	ns
t_{F}	Fall Time for data and clock pin	-	-	300	ns
t_{IDLE}	Idle Time before a new transmission can start	1.3	-	-	us

I²C interface Timing characteristics

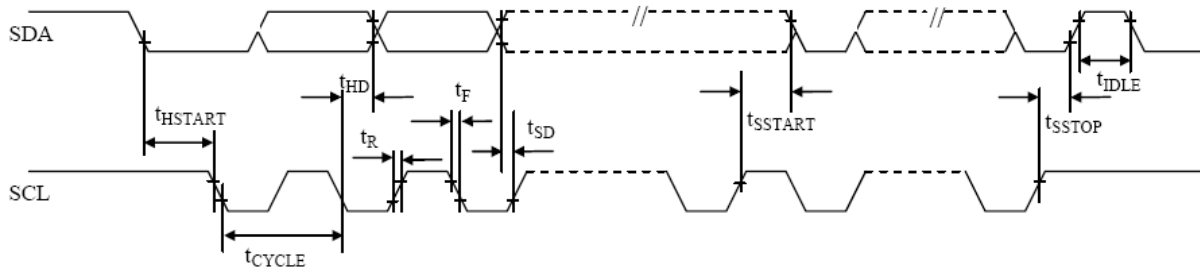

9 Functional Specification and Application Circuit

9.1 Power ON and Power OFF Sequence

Power ON Sequence:

1. Power ON V_{DD}
2. After V_{DD} become stable, set RES# pin LOW (logic low) for at least $3\mu s$ (t_1)⁽⁴⁾ and then HIGH (logic high).
3. After set RES# pin LOW (logic low), wait for at least $3\mu s$ (t_2). Then Power ON V_{CC} ⁽¹⁾.
4. After V_{CC} become stable, send command AFh for display ON. SEG/COM will be ON after $100ms$ (t_{AF}).

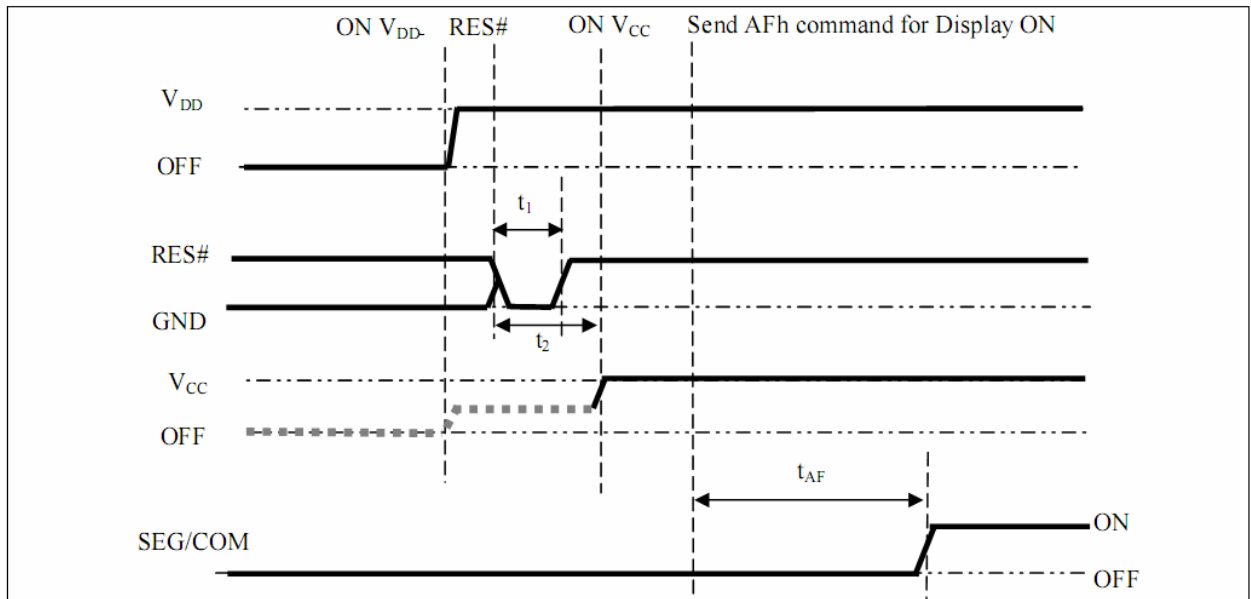

Power OFF Sequence:

1. Send command AEh for display OFF.
2. Power OFF V_{CC} ^{(1),(2),(3)}.
3. Power OFF V_{DD} after t_{OFF} .⁽⁵⁾ (Typical $t_{OFF}=100ms$)

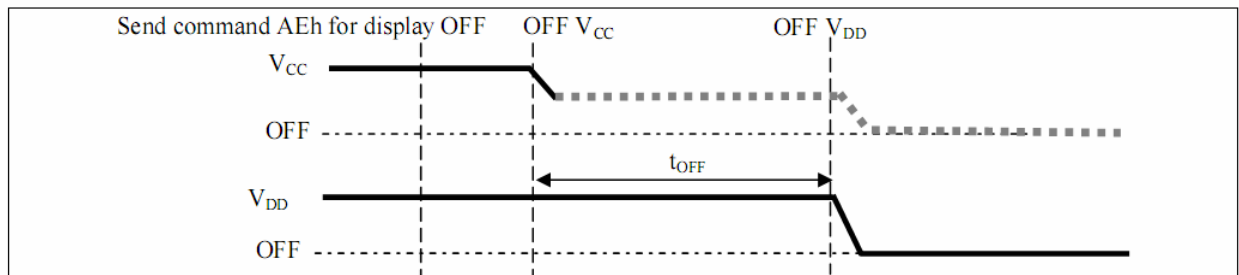

Note:

- (1) Since an ESD protection circuit is connected between V_{DD} and V_{CC} , V_{CC} becomes lower than V_{DD} whenever V_{DD} is ON and V_{CC} is OFF as shown in the dotted line of V_{CC} in above figures.
- (2) V_{CC} should be kept float (disable) when it is OFF.
- (3) Power Pins(V_{DD} , V_{CC}) can never be pulled to ground under any circumstance.
- (4) The register values are reset after t_1 .
- (5) V_{DD} should not be Power OFF before V_{CC} Power OFF

9.2 Application Circuit

The configuration for 8080-parallel interface mode, external VCC is shown in the following diagram:

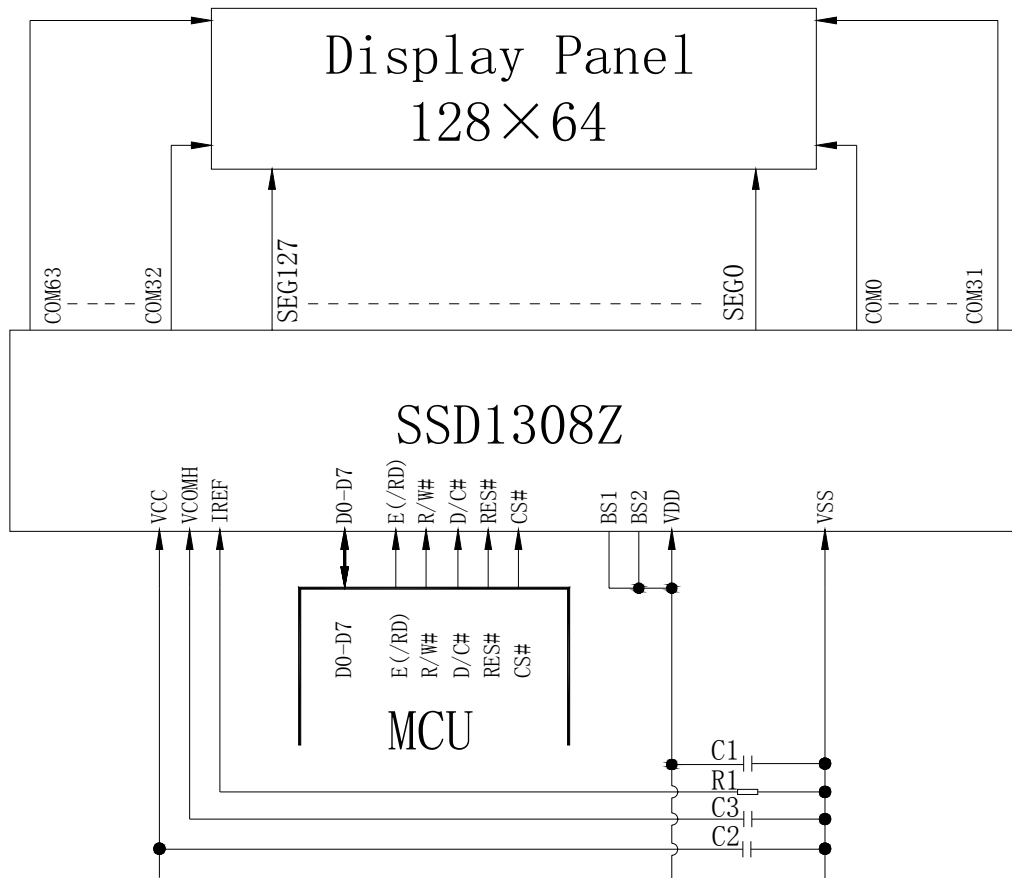

Pin connected to MCU interface: D[7:0], E(/RD), R/W#, D/C#, RES# , CS#

Recommended components

C1: 1.0 μ F

C2: 2.2 μ F

C3: 2.2 μ F

R1: 500k Ω , $R1 = (\text{Voltage at IREF} - \text{GND}) / \text{IREF}$

Voltage at IREF pin = VCC-3V

9.3 Display Control Instruction



Refer to SSD1308 IC Specification.

9.4 Recommended Software Initialization

```
void init_program()
{
    write_c(0xae);    // display off
    write_c(0xa1);    //segment remap
    write_c(0xda);    //common pads hardware: alternative
    write_c(0x12);
    write_c(0xc8);    //common output scan direction:com63~com0
    write_c(0xa8);    //multiplex ration mode:63
    write_c(0x3f);
    write_c(0xd5);    //display divide ratio/osc. freq. mode
    write_c(0x80);
    write_c(0x81);    //contrast control
    write_c(0x50);
    write_c(0xd9);    //set pre-charge period
    write_c(0x21);
    write_c(0x20);    //Set Memory Addressing Mode
    write_c(0x02);
    write_c(0xdb);    //VCOM deselect level mode
    write_c(0x30);
    write_c(0xad);    //master configuration
    write_c(0x00);
    write_c(0xa4);    //out follows RAM content
    write_c(0xa6);    //set normal display
    write_c(0xaf);    // display on
}
```

10 Package Specification

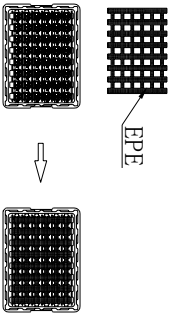
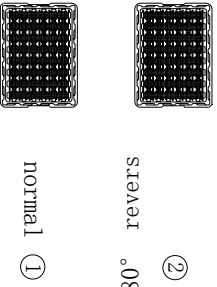
Package order (1) ~ (9)

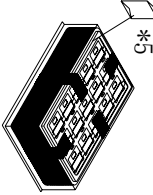
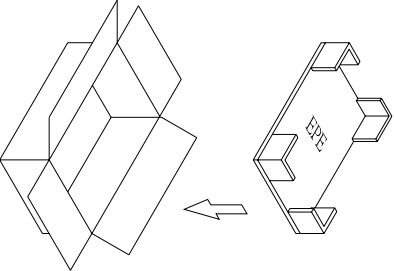
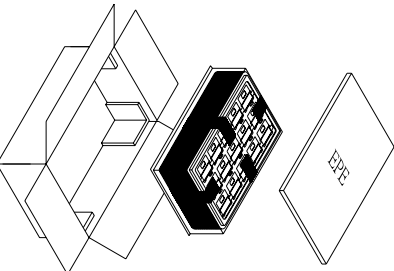
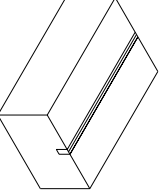
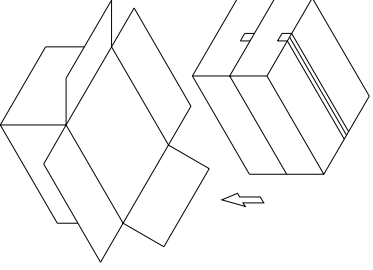
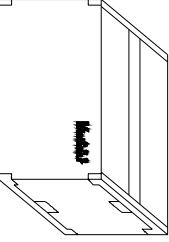
<p>(1) Tray: 370*273 t=0.8mm Add EPE in every contained tray</p> 	<p>(2)</p>  <p>normal ① stair ②</p>	<p>(3) order ① ② ① ② fix trays with tape Package quantity products: 672 pcs of 1 small carton 1 tray contain 48 pcs 14 contained trays, 1 empty tray</p> 	<p>(4) package with plastic bags add five desiccants create a power vacuum</p>  <p>*5</p>
<p>(5)</p> 	<p>(6)</p> 	<p>(7)</p>  <p>small carton package L425*W330*L175 mm</p>	<p>(8)</p>  <p>2 small cartons in 1 big carton</p>
<p>(9)</p> <p>28 contained trays, 2 empty trays, Package quantity products: 1344 pcs of 1 big carton</p>  <p>Package finished L450*W350*L360 mm</p>			

NOTE: Tape on the small carton & big carton

PRODUCT SPECIFICATION

11 Reliability

11.1 Reliability Test

NO.	ITEM	CONDITION	QUANTITY
1	High Temperature (Non-operation)	80°C,240hrs	4
2	Low Temperature (Non-operation)	-30°C,240hrs	4
3	High Temperature (Operation)	70°C,240hrs	4
4	Low Temperature (Operation)	-20°C,240hrs	4
5	High Temperature / High Humidity (Operation)	60°C,90%RH,240hrs	4
6	Thermal shock (Non-operation)	-30°C~80°C(-30°C/30min;transit/3min;80°C/30min;transit/3min) 1cycle: 66min,30cycles	4
7	Vibration	Frequency: 5~50Hz,0.5G Scan rate: 1 oct/min Time: 2 hrs/axis Test axis: X, Y, Z	1 Carton
8	Drop	Height: 100 cm Sequence: 1 angle, 3 edges and 6 faces	1 Carton

Test and measurement conditions

1. All measurements shall not be started until the specimens attain to temperature stability, the stable time is at least 15 minutes.
2. The degradation of polarizer is ignored for item 5.
3. The tolerance of temperature is $\pm 3^{\circ}\text{C}$, and the tolerance of relative humidity is $\pm 5\%$.

Evaluation criteria

1. The function test is OK.
2. No observable defects.
3. Luminance: $\geq 50\%$ of initial value.
4. Current consumption: within $\pm 50\%$ of initial value.

11.2 Lifetime

End of lifetime is specified as 50% of initial brightness and the test pattern at operating condition is 50% alternating checkerboard.

ITEM	MIN	MAX	UNIT	CONDITION
Operation Life Time	20000	-	hrs	100 cd/m ² ,50% Checkerboard

An average operating lifetime of more than 10,000 hrs (checkerboard) at room temperature is approached by 240 hrs @ 80°C operating.

11.3 Failure Check Standard

After the completion of the described reliability test, the samples were left at room temperature for 2 hrs prior to conducting the failure test at $22\pm 3^{\circ}\text{C}$; $55\pm 15\%$ RH.

12 Illustration of OLED Product Name

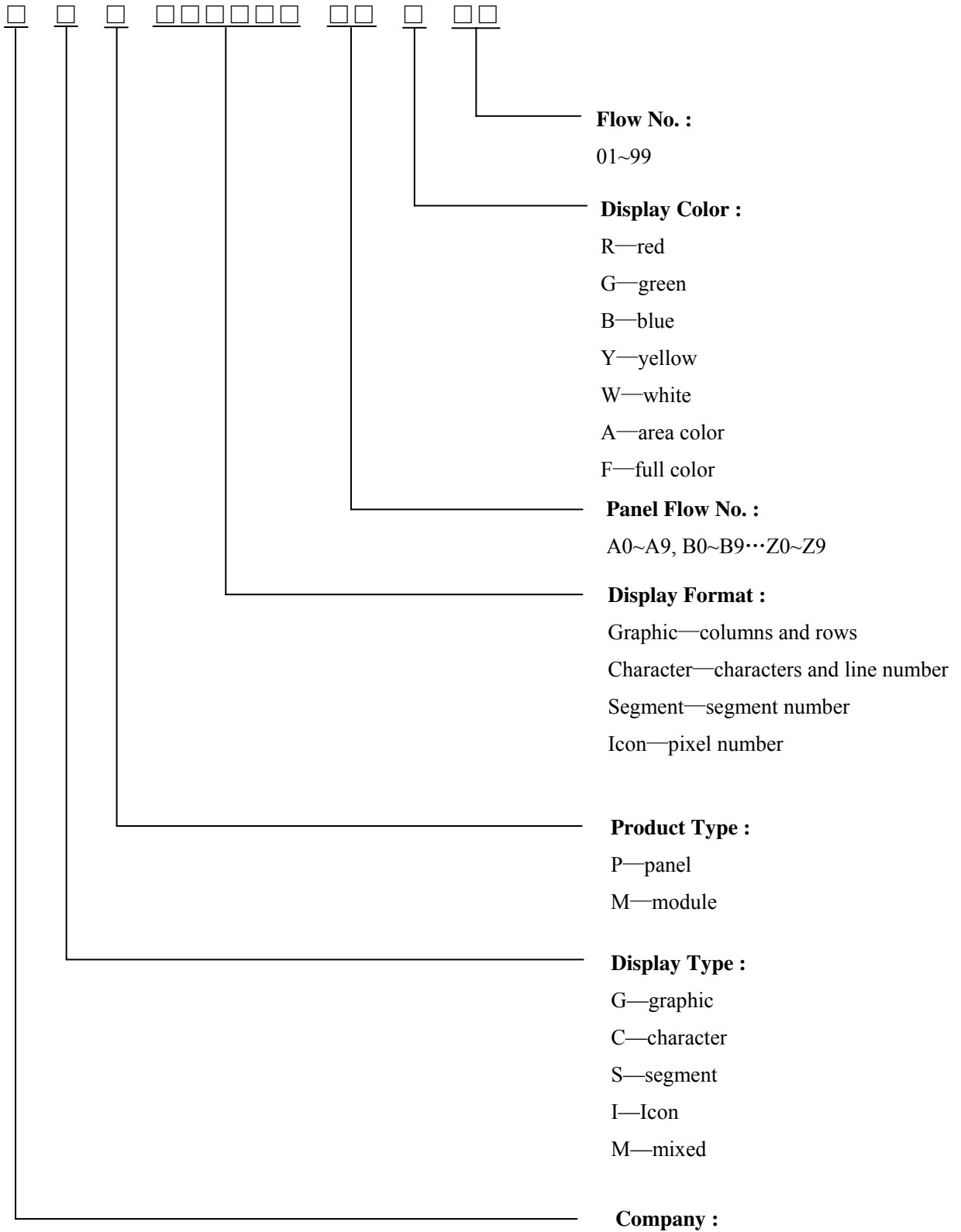

13 Outgoing Quality Control Specifications

13.1 Sampling Method

- (1) GB/T 2828.1-2003/ISO2859-1: 1999, inspection level II , normal inspection, single sample inspection
- (2) AQL: Major 0.65; Minor 1.0

13.2 Inspection Conditions

The environmental conditions for test and measurement are performed as follows.

Temperature: $22\pm 3^{\circ}\text{C}$

Humidity: $55\pm 15\%\text{R.H}$

Fluorescent Lamp: 30W

Distance between the Panel & Lamp: $\geq 50\text{cm}$

Distance between the Panel & Eyes: $\geq 30\text{cm}$

Viewing angle from the vertical in each direction: $\leq 45^{\circ}$

(See the sketch below)

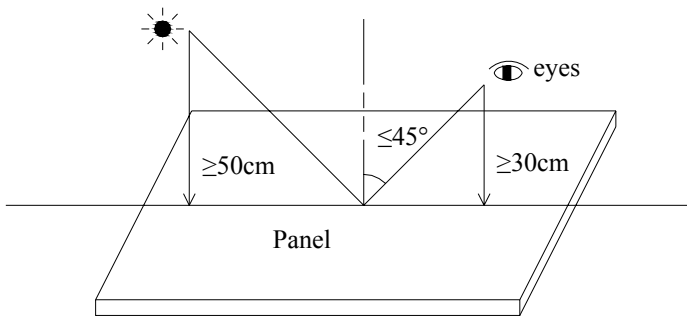

13.3 Quality Assurance Zones

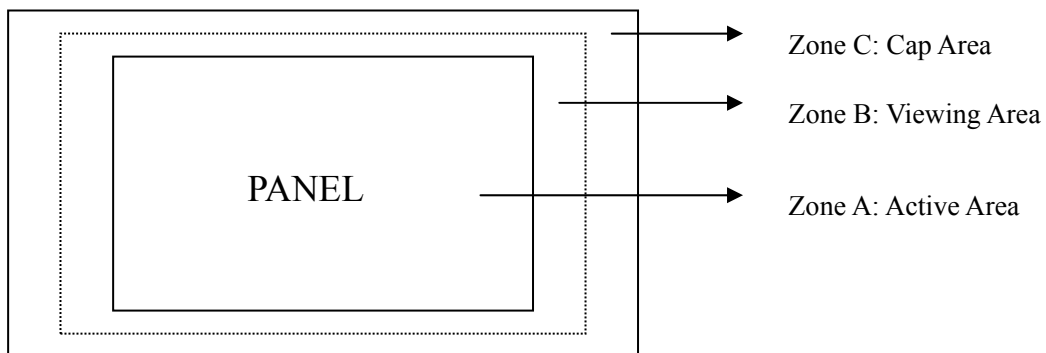

PRODUCT SPECIFICATION

13.4 Inspection Standard

Definition of Φ &L&W (Unit: mm)

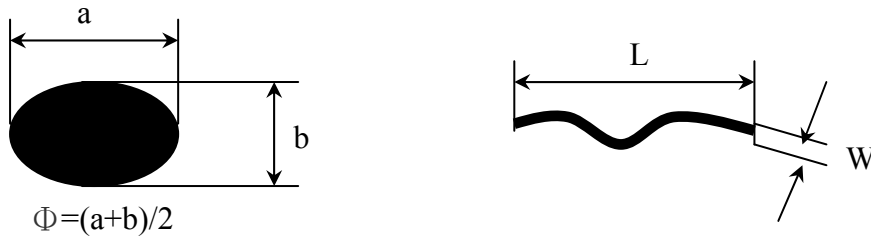

I . Appearance Defects

NO.	ITEM	CRITERIA	CLASSIFICATION																
1	Polarizer Black or White spot, Dirty spot, Foreign matter, Dent on the polarizer	<table border="1"> <thead> <tr> <th rowspan="2">Average Diameter (mm)</th> <th colspan="2">Acceptable Number</th> </tr> <tr> <th>Zone A,B</th> <th>Zone C</th> </tr> </thead> <tbody> <tr> <td>$\Phi \leq 0.15$</td> <td>Ignore</td> <td rowspan="3">Ignore</td> </tr> <tr> <td>$0.15 < \Phi \leq 0.30$</td> <td>3</td> </tr> <tr> <td>$\Phi > 0.30$</td> <td>0</td> </tr> </tbody> </table>	Average Diameter (mm)	Acceptable Number		Zone A,B	Zone C	$\Phi \leq 0.15$	Ignore	Ignore	$0.15 < \Phi \leq 0.30$	3	$\Phi > 0.30$	0	Minor				
Average Diameter (mm)	Acceptable Number																		
	Zone A,B	Zone C																	
$\Phi \leq 0.15$	Ignore	Ignore																	
$0.15 < \Phi \leq 0.30$	3																		
$\Phi > 0.30$	0																		
2	Scratch/line on the glass/Polarizer	<table border="1"> <thead> <tr> <th rowspan="2">Width (mm)</th> <th rowspan="2">Length (mm)</th> <th colspan="2">Acceptable Number</th> </tr> <tr> <th>Zone A,B</th> <th>Zone C</th> </tr> </thead> <tbody> <tr> <td>$W \leq 0.03$</td> <td>---</td> <td>Ignore</td> <td rowspan="3">Ignore</td> </tr> <tr> <td>$0.03 < W \leq 0.08$</td> <td>$L \leq 5.0$</td> <td>3</td> </tr> <tr> <td>$W > 0.08$</td> <td>---</td> <td>0</td> </tr> </tbody> </table>	Width (mm)	Length (mm)	Acceptable Number		Zone A,B	Zone C	$W \leq 0.03$	---	Ignore	Ignore	$0.03 < W \leq 0.08$	$L \leq 5.0$	3	$W > 0.08$	---	0	Minor
Width (mm)	Length (mm)	Acceptable Number																	
		Zone A,B	Zone C																
$W \leq 0.03$	---	Ignore	Ignore																
$0.03 < W \leq 0.08$	$L \leq 5.0$	3																	
$W > 0.08$	---	0																	
3	Polarizer Bubble	<table border="1"> <thead> <tr> <th rowspan="2">Average Diameter (mm)</th> <th colspan="2">Acceptable Number</th> </tr> <tr> <th>Zone A,B</th> <th>Zone C</th> </tr> </thead> <tbody> <tr> <td>$\Phi > 0.5$</td> <td>0</td> <td rowspan="3">Ignore</td> </tr> <tr> <td>$0.2 < \Phi \leq 0.5$</td> <td>3</td> </tr> <tr> <td>$\Phi \leq 0.2$</td> <td>Ignore</td> </tr> </tbody> </table>	Average Diameter (mm)	Acceptable Number		Zone A,B	Zone C	$\Phi > 0.5$	0	Ignore	$0.2 < \Phi \leq 0.5$	3	$\Phi \leq 0.2$	Ignore	Minor				
Average Diameter (mm)	Acceptable Number																		
	Zone A,B	Zone C																	
$\Phi > 0.5$	0	Ignore																	
$0.2 < \Phi \leq 0.5$	3																		
$\Phi \leq 0.2$	Ignore																		
4	Any Dirt & Scratch on Polarizer's Protective Film	Ignore for not affect the polarizer.	Acceptable																
5	Any Dirt on Cap Glass	<table border="1"> <thead> <tr> <th>Average Diameter (mm)</th> <th>Acceptable Number</th> </tr> </thead> <tbody> <tr> <td>$\Phi \leq 0.5$</td> <td>Ignore</td> </tr> <tr> <td>$0.5 < \Phi \leq 1.0$</td> <td>3</td> </tr> <tr> <td>$\Phi > 1.0$</td> <td>0</td> </tr> </tbody> </table>	Average Diameter (mm)	Acceptable Number	$\Phi \leq 0.5$	Ignore	$0.5 < \Phi \leq 1.0$	3	$\Phi > 1.0$	0	Minor								
Average Diameter (mm)	Acceptable Number																		
$\Phi \leq 0.5$	Ignore																		
$0.5 < \Phi \leq 1.0$	3																		
$\Phi > 1.0$	0																		

PRODUCT SPECIFICATION

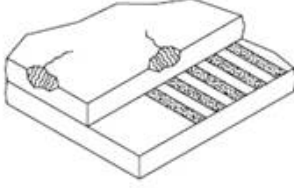
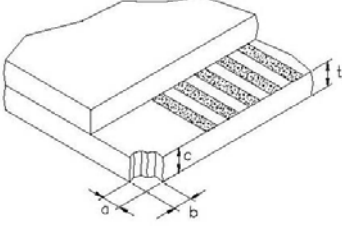
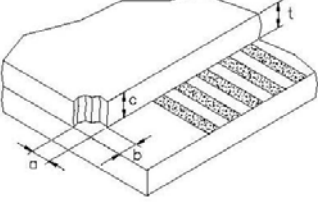
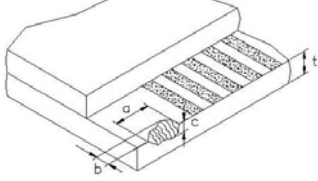
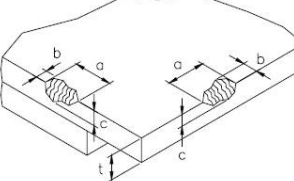
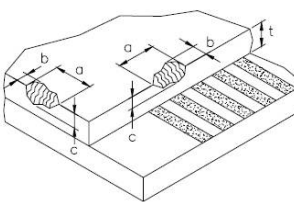
5	Glass Crack	 <p>Propagation crack is not acceptable.</p>	Major
6	Corner Chip	 <p>t= Glass thickness Accept $a \leq 2.0\text{mm}$ or $b \leq 2.0\text{mm}$, $c \leq t$</p>	Minor
7	Corner Chip on Cap Glass	 <p>t= Glass thickness Accept $a \leq 1.5\text{mm}$ or $b \leq 1.5\text{mm}$, $c \leq t$</p>	Minor
8	Chip on Contact Pad	 <p>t= Glass thickness Accept $a \leq 3.0\text{mm}$ or $b \leq 0.8\text{mm}$, $c \leq t$ (on the contact pin) $a \leq 3.0\text{mm}$ or $b \leq 1.5\text{mm}$, $c \leq t$ (outside of the contact pin)</p>	Minor
9	Chip on Face of Display	 <p>t= Glass thickness Accept $a \leq 1.5\text{mm}$ or $b \leq 1.5\text{mm}$, $c \leq t$</p>	Minor
10	Chip on Cap Glass	 <p>t= Glass thickness Accept $a \leq 3.0\text{mm}$ or $b \leq 3.0\text{mm}$, $c \leq t/2$ $a \leq 1.5\text{mm}$ or $b \leq 1.5\text{mm}$, $t/2 \leq c \leq t$</p>	Minor
11	Stain on Surface	Stain removable by soft cloth or air blow is acceptable.	Minor
12	TCP/FPC Damage	<p>(1) Crack, deep scratch, deep hole and deep pressure mark on the TCP/FPC are not acceptable.</p> <p>(2) Terminal lead twisted or broken is not allowable.</p> <p>(3) Copper exposed is not allowed by naked eye inspection.</p>	Minor
13	Dimension Unconformity	Checking by mechanical drawing.	Major

PRODUCT SPECIFICATION

II . Displaying Defects

NO.	ITEM	CRITERIA	CLASSIFICATION												
1	Black/White spot Dirty spot Foreign matter	<table border="1"><thead><tr><th rowspan="2">Average Diameter (mm)</th><th colspan="2">Pieces Permitted</th></tr><tr><th>Zone A,B</th><th>Zone C</th></tr></thead><tbody><tr><td>$\Phi \leq 0.10$</td><td>Ignore</td><td rowspan="3">Ignore</td></tr><tr><td>$0.10 < \Phi \leq 0.20$</td><td>3</td></tr><tr><td>$\Phi > 0.20$</td><td>0</td></tr></tbody></table>	Average Diameter (mm)	Pieces Permitted		Zone A,B	Zone C	$\Phi \leq 0.10$	Ignore	Ignore	$0.10 < \Phi \leq 0.20$	3	$\Phi > 0.20$	0	Minor
		Average Diameter (mm)		Pieces Permitted											
			Zone A,B	Zone C											
		$\Phi \leq 0.10$	Ignore	Ignore											
$0.10 < \Phi \leq 0.20$	3														
$\Phi > 0.20$	0														
2	No Display	Not allowable.	Major												
3	Irregular Display	Not allowable.	Major												
4	Missing Line (row or column)	Not allowable.	Major												
5	Short	Not allowable.	Major												
6	Flicker	Not allowable.	Major												
7	Abnormal Color	Refer to the SPEC.	Major												
8	Luminance NG	Refer to the SPEC.	Major												
9	Over Current	Refer to the SPEC.	Major												

14 Precautions for operation and Storage

14.1 Precautions for Operation

- (1) Since OLED panel is made of glass, do not apply any mechanical shock or impact or excessive force to it when installing the OLED module. Any strong mechanical impact due to falling dropping etc. may cause damage (breakage or cracking).
 - (2) The polarizer on the OLED surface is made of soft material and is easily scratched. Please take most care when handing. When the surface of the polarizer of OLED Module is contaminated, please wipe it off gently by using moisten soft cloth with isopropyl alcohol, do not use water, ketone or aromatics. If there is saliva or water on the OLED surface, please wipe it off immediately.
 - (3) When handling OLED module, please be sure that the body and the tools are properly grounded. And do not touch I/O pins with bare hands or contaminate I/O pins, it will cause disconnection or defective insulation of terminals.
 - (4) Do not attempt to disassemble or process the OLED module.
 - (5) OLED module should be used under recommended operating conditions shown in the specification. Since the higher voltage leads to the shorter lifetime, be sure to use the specified operating voltage.
 - (6) Foggy dew, moisture condensation or water droplets deposited on surface and contact terminals will cause polarizer stain or damage, the deteriorated display quality and electrochemical reaction then leads to shorter life time and permanent damage to the module probably. Please pay attention to the environmental temperature and humidity.
 - (7) An afterimage is created by the difference in brightness between unused dot and the fixed dot, according to the decrease of brightness of the emitting time. Therefore, to avoid having an afterimage, the full set should be thoroughly used instead of using a fixed dot. When the fixed dot emits, an afterimage can be created.
 - (8) Flicker could be come out at full on display. And it disappears when frame frequency increase, but brightness decreases too.
-

PRODUCT SPECIFICATION

14.2 Soldering

- (1) Soldering should be performed only on the I/O terminals.
- (2) Use soldering irons with proper grounding and no leakage.
- (3) Iron: no higher than 300°C and 3~4 sec during soldering.

14.3 Precautions for Storage

- (1) Please store OLED module in a dark place. Avoid exposure to sunlight, the light of fluorescent lamp or any ultraviolet ray.
 - (2) Keep the environment temperature between 10°C and 35°C and the relative humidity less than 60%. Avoid high temperature and high humidity.
 - (3) Keep the OLED modules stored in the container when shipped from supplier before using them is recommended.
 - (4) Do not leave any article on the OLED module surface for an extended period of time.
-