

REVISIONS				
P	LTR	DESCRIPTION	DATE	APVD
	C3	REVISED PER ECO-21-007118	30JUN2021	RK DR

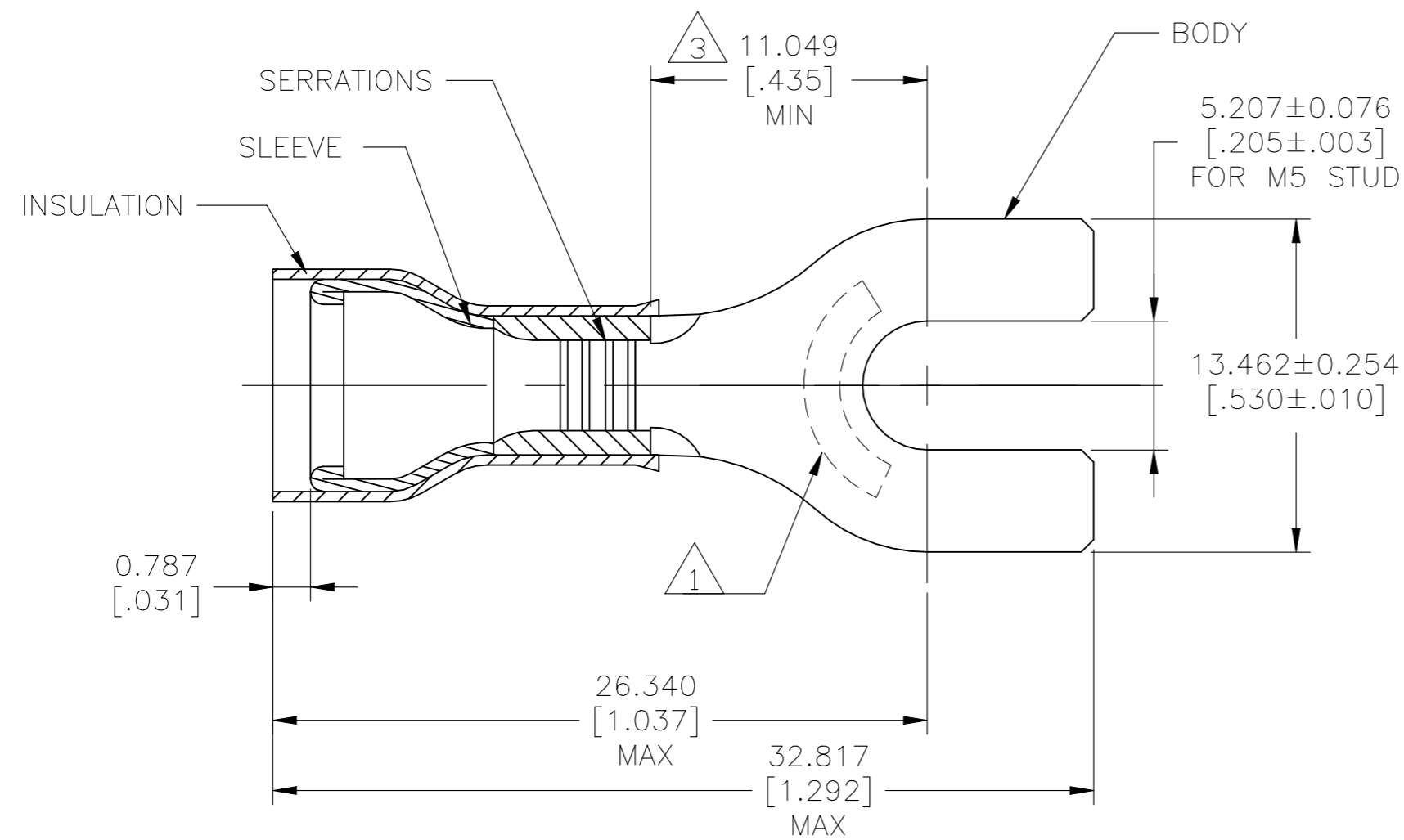

- 1 STAMP "AMP 12-10\*", APPROX AS SHOWN.
- 2 BODY MATERIAL THICKNESS IS 0.991± 0.051 [.039±.002]
- 3 APPLIES FROM EDGE OF METAL WIRE BARREL TO CENTER OF STUD HOLE.
- 4 WIRE INSULATION DIA 3.810-6.350 [.150-.250]
- 5 BODY - COPPER PER ASTM B152  
SLEEVE - COPPER PER ASTM B152  
INSULATION - NYLON
- 6 BODY - TIN PL 0.00254[.000100] MIN EXT THK PER ASTM B545  
SLEEVE - TIN PL 0.00254[.000100] MIN EXT THK PER ASTM B545  
INSULATION - COLOR - YELLOW
- 7 105°C [221 F] MAX OPERATING TEMPERATURE.
- 8 300 VOLT MAX
- 9 2.62-6.64mm<sup>2</sup> [5,180 - 13,100 CMA] SOLID OR STRANDED

500	LOOSE PIECE	130620
QTY	PACKAGE TYPE	PART NO

THIS DRAWING IS A CONTROLLED DOCUMENT.		DWN jr_ruth 13APR07	<b>STE</b> TE Connectivity	
DIMENSIONS: mm [INCHES]		CHK T MICHELUTTI 13APR07		
TOLERANCES UNLESS OTHERWISE SPECIFIED:		APVD T MICHELUTTI 13APR07	NAME	
0 PLC ± -		PRODUCT SPEC		
1 PLC ± -		UL 486A-B		
2 PLC ± -		APPLICATION SPEC		
3 PLC ± 0.127[.005]		114-2157		
4 PLC ± -		SIZE	CAGE CODE	DRAWING NO
ANGLES ± 5°		A3 00779		C-130620
MATERIAL	FINISH	WEIGHT		RESTRICTED TO
5	6	CUSTOMER DRAWING		—
		SCALE	SHEET	REV
		4:1	1 OF 1	C3