

512 Mb: HYPERRAM™ self-refresh dynamic RAM (DRAM) with Octal xSPI interface

1.8 V

Features

- Interface
 - xSPI (octal) Interface
 - 1.8 V Interface support
 - Single ended clock (CK) - 11 bus signals
 - Optional Differential clock (CK, CK#) - 12 bus signals
 - Chip Select (CS#)
 - 8-bit data bus (DQ[7:0])
 - Hardware reset (RESET#)
 - Bidirectional read-write data strobe (RWDS)
 - Output at the start of all transactions to indicate refresh latency
 - Output during read transactions as read data strobe
 - Input during write transactions as write data mask
- Performance, power, and packages
 - 200-MHz maximum clock rate
 - DDR - transfers data on both edges of the clock
 - Data throughput up to 400 MBps (3,200 Mbps)
 - Configurable burst characteristics
 - Linear burst
 - Wrapped burst lengths:
 - 16 bytes (8 clocks)
 - 32 bytes (16 clocks)
 - 64 bytes (32 clocks)
 - 128 bytes (64 clocks)
 - Hybrid option - one wrapped burst followed by linear burst on 256 Mb. Linear Burst across die boundary is not supported.
 - Configurable output drive strength
 - Power modes
 - Hybrid sleep mode
 - Deep power down
 - Arrays refresh
 - Partial memory array (1/8, 1/4, 1/2, and so on)
 - Full
 - Package
 - 24-ball FBGA
 - Operating Temperature Range
 - Industrial (I): -40 °C to +85 °C
 - Industrial Plus (V): -40 °C to +105 °C
 - Automotive, AEC-Q100 Grade 3: -40 °C to +85 °C
 - Automotive, AEC-Q100 Grade 2: -40 °C to +105 °C
 - Automotive, AEC-Q100 Grade 1: -40 °C to +125 °C
- Technology
 - 25-nm DRAM

Performance summary

Read transaction timings	Unit
Maximum clock rate at 1.8 V V_{CC}/V_{CCQ}	200 MHz
Maximum access time, (t_{ACC})	35 ns

Maximum current consumption	Unit
Burst read or write (linear burst at 200 MHz)	40 mA/44 mA
Standby (105 °C)	3.1 mA
Deep power down (105 °C)	30 μ A

Logic block diagram

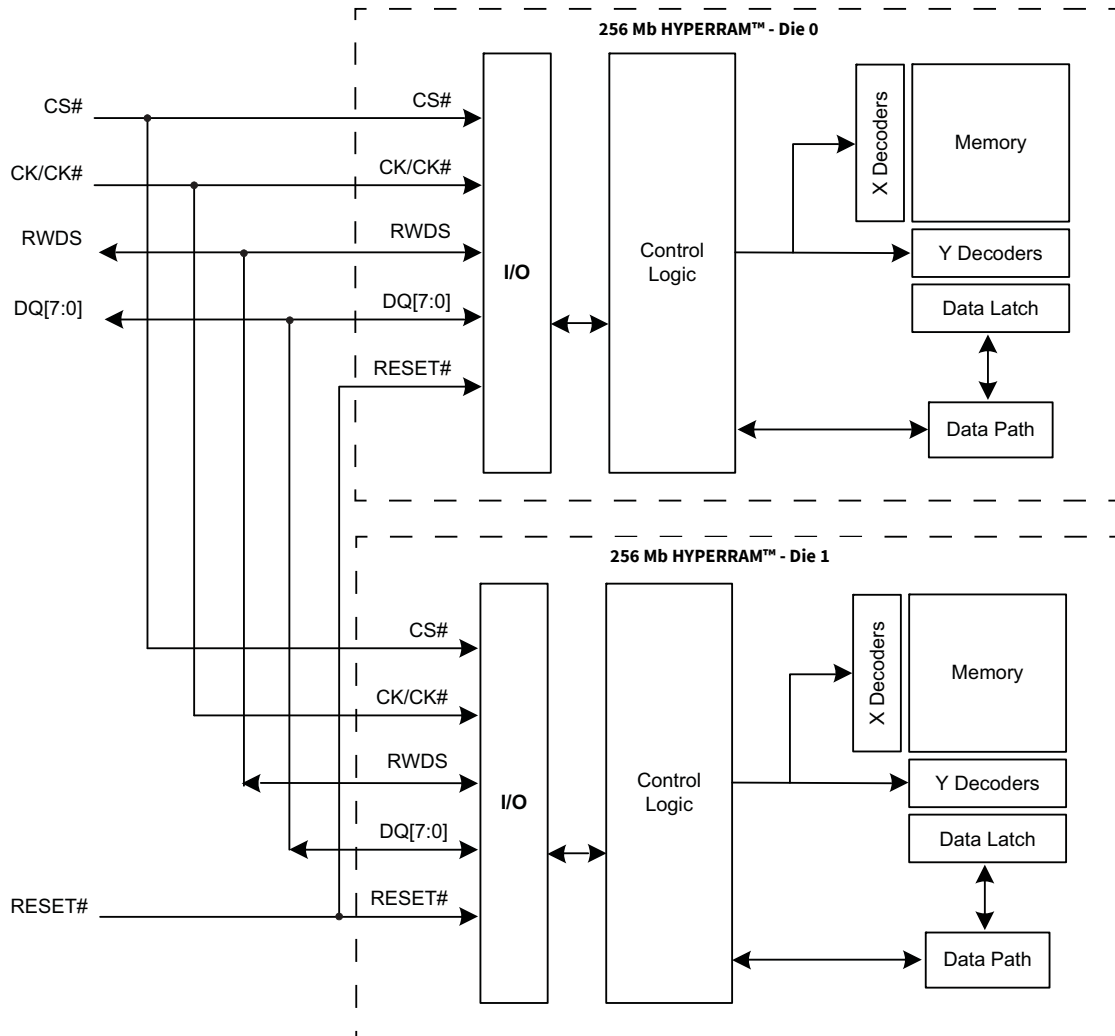

Table of contents

1 General description	5
1.1 xSPI (Octal) interface	5
2 Product overview	7
2.1 xSPI (octal) interface.....	7
3 Signal description	8
3.1 Input/output summary.....	8
4 xSPI (octal) transaction details	9
4.1 Command/address/data bit assignments.....	10
4.2 RESET ENABLE transaction	11
4.3 RESET transaction.....	11
4.4 READ ID transaction.....	12
4.5 DEEP POWER DOWN transaction	13
4.6 READ transaction	13
4.7 WRITE transaction.....	14
4.8 WRITE ENABLE transaction	14
4.9 WRITE DISABLE Transaction.....	15
4.10 READ ANY REGISTER transaction	15
4.11 WRITE ANY REGISTER transaction.....	16
4.12 Data placement during memory READ/WRITE transactions	17
4.13 Data placement during register READ/WRITE transactions.....	18
5 Memory space	19
5.1 xSPI (octal) interface.....	19
5.2 Density and row boundaries	19
6 Register space access	20
6.1 xSPI (octal) interface.....	20
6.2 Device identification registers.....	21
6.3 Device configuration registers	22
7 Interface states	28
8 Power conservation modes	29
8.1 Interface standby.....	29
8.2 Active clock stop	29
8.3 Hybrid sleep	30
8.4 Deep power down	31
9 Electrical specifications	32
9.1 Absolute maximum ratings	32
9.2 Input signal overshoot.....	32
9.3 Latch-up characteristics	33
9.4 Operating ranges	33
9.5 DC characteristics	34
9.6 Power-up initialization	38
9.7 Power down	39
9.8 Hardware reset.....	40
10 Timing specifications	41
10.1 Key to switching waveforms.....	41
10.2 AC test conditions	41
10.3 CLK characteristics	42
10.4 AC characteristics.....	43
10.5 Timing reference levels.....	46
11 Physical interface	47
11.1 FBGA 24-ball 5 x 5 array footprint	47
11.2 Physical diagram.....	48

Table of contents

12 Ordering information	49
12.1 Ordering part number.....	49
12.2 Valid combinations	50
12.3 Valid combinations - Automotive grade / AEC-Q100.....	50
13 Acronyms	51
14 Document conventions.....	52
14.1 Units of measure	52
Revision history	53

1 General description

The 512-Mb HYPERRAM™ device is a high-speed CMOS, self-refresh DRAM, with xSPI (Octal) interface. The DRAM array uses dynamic cells that require periodic refresh. Refresh control logic within the device manages the refresh operations on the DRAM array when the memory is not being actively read or written by the xSPI interface master (host). Since the host is not required to manage any refresh operations, the DRAM array appears to the host as though the memory uses static cells that retain data without refresh. Hence, the memory is more accurately described as pseudo static RAM (PSRAM).

Since the DRAM cells cannot be refreshed during a read or write transaction, there is a requirement that the host limit read or write burst transfers lengths to allow internal logic refresh operations when they are needed. The host must confine the duration of transactions and allow additional initial access latency, at the beginning of a new transaction, if the memory indicates a refresh operation is needed. The dual-die, 512-Mb HYPERRAM™ chip supports data transactions with additional (2X) latency only.

1.1 xSPI (Octal) interface

xSPI (Octal) is a SPI-compatible low signal count, DDR interface supporting eight I/Os. The DDR protocol in xSPI (Octal) transfers two data bytes per clock cycle on the DQ input/output signals. A read or write transaction on xSPI (Octal) consists of a series of 16-bit wide, one clock cycle data transfers at the internal RAM array with two corresponding 8-bit wide, one-half-clock-cycle data transfers on the DQ signals. All inputs and outputs are LV-CMOS compatible. Device are available as 1.8 V V_{CC}/V_{CCQ} (nominal) for array (V_{CC}) and I/O buffer (V_{CCQ}) supplies, through different ordering part number (OPN).

Each transaction on xSPI (Octal) must include a command whereas address and data are optional. The transactions are structures as follows:

- Each transaction begins with CS# going LOW and ends with CS# returning HIGH.
- The serial clock (CK) marks the transfer of each bit or group of bits between the host and memory. All transfers occur on every CK edge (DDR mode).
- Each transaction has a 16-bit command which selects the type of device operation to perform. The 16-bit command is based on two 8-bit opcodes. The same 8-bit opcode is sent on both edges of the clock.
- A command may be stand-alone or may be followed by address bits to select a memory location in the device to access data.
- Read transactions require a latency period after the address bits and can be zero to several CK cycles. CK must continue to toggle during any read transaction latency period. During the command and address parts of a transaction, the memory indicates that an additional latency period is needed for a required refresh time (t_{RFH}) by driving the RWDS signal to the HIGH state.
- Write transactions to registers do not require a latency period.
- Write transactions to the memory array require a latency period after the address bits and can be zero to several CK cycles. CK must continue to toggle during any write transaction latency period. During the command and address parts of a transaction, the memory indicates that an additional latency period is needed for a required refresh time (t_{RFH}) by driving the RWDS signal to the HIGH state.
- In all transactions, command and address bits are shifted in the device with the most significant bits (MSb) first. The individual data bits within a data byte are shifted in and out of the device MSb first as well. All data bytes are transferred with the lowest address byte sent out first.

General description

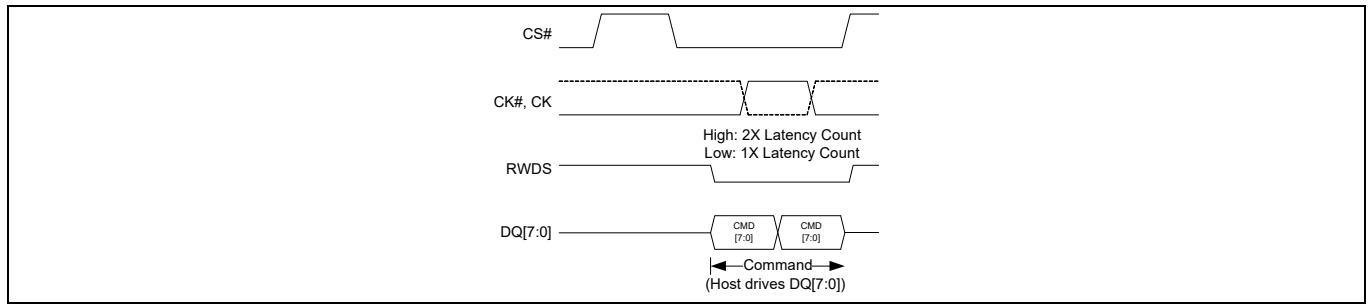

Figure 1 xSPI (octal) command only transaction (DDR)^[1]

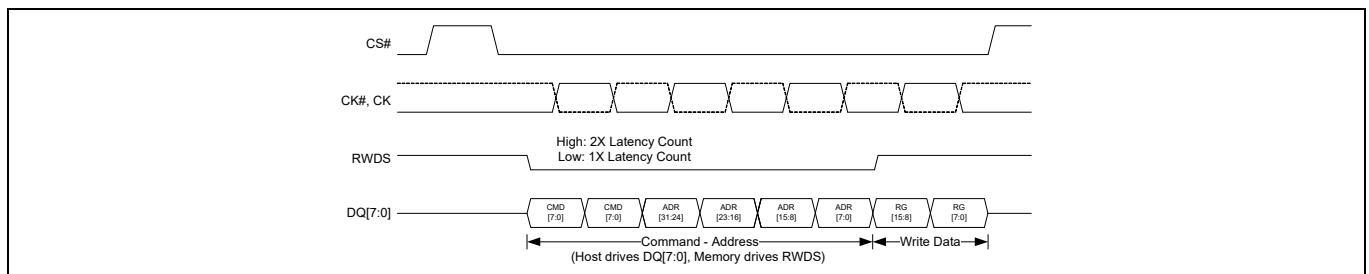

Figure 2 xSPI (octal) write with no latency transaction (DDR) (register writes)^[2]

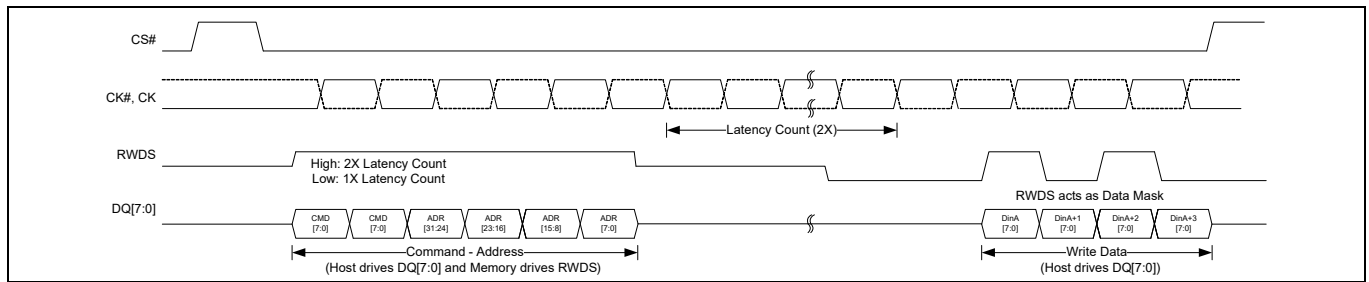

Figure 3 xSPI (octal) write with 2X latency transaction (DDR) (memory array writes)^[1, 3, 5]

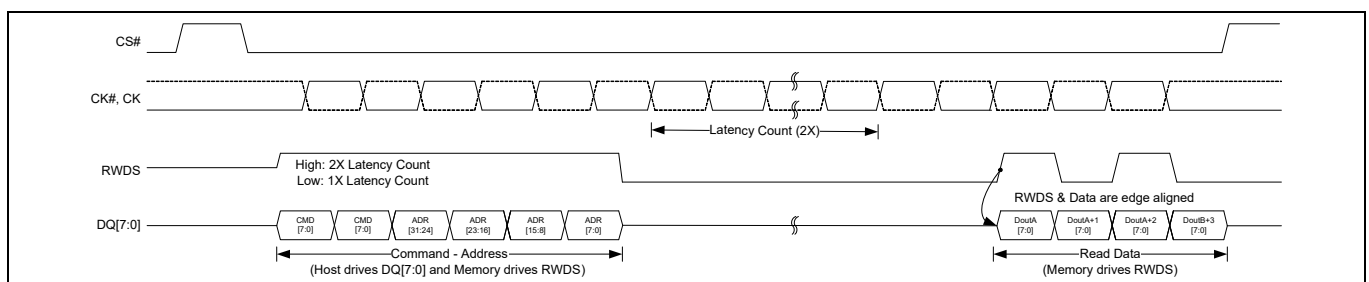

Figure 4 xSPI (octal) read with 2X latency transaction (DDR) (all reads)^[1, 5]

Notes

1. The initial latency “Low = 1x Latency Count” is not applicable in dual-die, 512 Mb HYPERRAM™.
2. Write with no latency transaction is used for register writes only.
3. RWDS is driven by HYPERRAM™ during Command and Address cycles for 2X latency and then driven by the host for data masking.
4. Data DinA and DinA+2 are masked.
5. RWDS is driven by HYPERRAM™ during Command & Address cycles for 2X latency and then driven again phase aligned with data.

2 Product overview

The 512-Mb HYPERRAM™ device is 1.8 V array and I/O, synchronous self-refresh Dynamic RAM (DRAM). The HYPERRAM™ device provides an xSPI (Octal) slave interface to the host system. The xSPI (Octal) interface has an 8-bit (1 byte) wide DDR data bus and use only word-wide (16-bit data) address boundaries. Read transactions provide 16 bits of data during each clock cycle (8 bits on both clock edges). Write transactions take 16 bits of data from each clock cycle (8 bits on each clock edge).

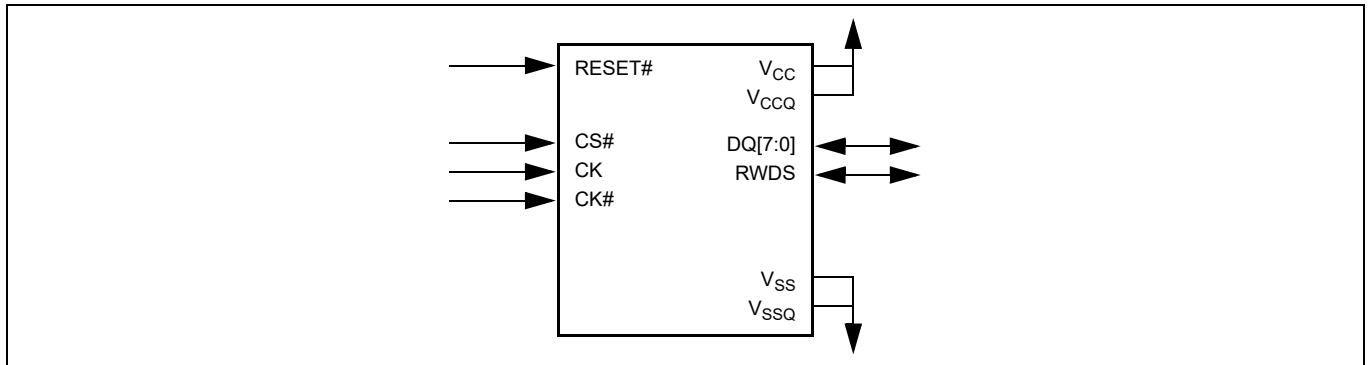

Figure 5 xSPI (octal) HYPERRAM™ interface^[6]

2.1 xSPI (octal) interface

Read and write transactions require three clock cycles to define the target row/column address and then an initial access latency of t_{ACC} . During the CA part of a transaction, the memory indicates an additional latency for a required refresh time (t_{RFH}) by driving the RWDS signal to the HIGH state. During a read (or write) transaction, after the initial data value has been output (or input), additional data can be read from (or written to) the row on subsequent clock cycles in either a wrapped or linear sequence. When configured in linear burst mode, the device will automatically fetch the next sequential row from the memory array to support a continuous linear burst. Simultaneously accessing the next row in the array while the read or write data transfer is in progress, allows for a linear sequential burst operation that can provide a sustained data rate of 400 MBps (1 byte (8 bit data bus) * 2 (data clock edges) * 200 MHz = 400 MBps).

Note

6. CK# is used in differential clock mode, but optional.

3 Signal description

3.1 Input/output summary

The xSPI (Octal) HyperRAM signals are shown in [Table 1](#). Active Low signal names have a hash symbol (#) suffix.

Table 1 I/O summary

Symbol	Type	Description
CS#	Input	Chip select. Bus transactions are initiated with a HIGH to LOW transition. Bus transactions are terminated with a Low to High transition. The master device has a separate CS# for each slave.
CK, CK#[7]	Input	Differential clock. Command, address, and data information is output with respect to the crossing of the CK and CK# signals. Use of differential clock is optional. Single ended clock. CK# is not used, only a single ended CK is used. The clock is not required to be free-running.
DQ[7:0]	Input/output	Data input/output. Command, address, and data information is transferred on these signals during read and write transactions.
RWDS	Input/output	Read-write data strobe. During the command/address portion of all bus transactions RWDS is a slave output and indicates whether additional initial latency is required. Slave output during read data transfer, data is edge aligned with RWDS. Slave input during data transfer in write transactions to function as a data mask. The dual-die, 512-Mb HYPERRAM™ chip supports data transactions with additional (2X) latency only.
RESET#	Input, internal pull-up	Hardware RESET. When LOW, the slave device will self initialize and return to the Standby state. RWDS and DQ[7:0] are placed into the HIGH-Z state when RESET# is LOW. The slave RESET# input includes a weak pull-up, if RESET# is left unconnected it will be pulled up to the HIGH state.
V _{CC}	Power supply	Array power.
V _{CCQ}	Power supply	Input/output power.
V _{SS}	Power supply	Array ground.
V _{SSQ}	Power supply	Input/output ground.
RFU	No connect	Reserved for future use. May or may not be connected internally, the signal/ball location should be left unconnected and unused by PCB routing channel for future compatibility. The signal/ball may be used by a signal in the future.

Note

- CK# is used in differential clock mode, but optional connection. Tie the CK# input pin to either V_{CCQ} or V_{SSQ} if not connected to the host controller, but do not leave it floating.

4 xSPI (octal) transaction details

The xSPI (octal) master begins a transaction by driving CS# LOW while clock is idle. Then the clock begins toggling while CA words are transferred.

For memory Read and Write transactions, the xSPI (octal) master then continues clocking for a number of cycles defined by the latency count setting in configuration register 0 (register write transactions do not require any latency count). The initial latency count required for a particular clock frequency is based on RWDS. If RWDS is LOW during the CA cycles, one latency count is inserted. If RWDS is HIGH during the CA cycles, an additional latency count is inserted. Once these latency clocks have been completed the memory starts to simultaneously transition the RWDS and output the target data. The dual-die, 512-Mb HYPERRAM™ chip supports data transactions with additional (2X) latency only.

During the read data transfers, read data is output edge aligned with every transition of RWDS. Data will continue to be output as long as the host continues to transition the clock while CS# is LOW. Note that burst transactions should not be so long as to prevent the memory from doing distributed refreshes.

During the write data transfers, write data is center-aligned with the clock edges. The first byte of data in each word is captured by the memory on the rising edge of CK and the second byte is captured on the falling edge of CK. RWDS is driven by the host master interface as a data mask. When data is being written and RWDS is HIGH the byte will be masked and the array will not be altered. When data is being written and RWDS is LOW the data will be placed into the array. Because the master is driving RWDS during write data transfers, neither the master nor the HyperRAM device are able to indicate a need for latency within the data transfer portion of a write transaction. The acceptable write data burst length setting is also shown in configuration register 0.

Wrapped bursts will continue to wrap within the burst length and linear burst will output data in a sequential manner across row boundaries. When a linear burst read reaches the last address in the array, continuing the burst beyond the last address will provide data from the beginning of the address range. Linear burst across die boundary is not supported. In case of the linear burst access, if the address auto increments to the specific die boundary (either die 0 or die 1), the address will wrap around the specific die boundary. Read transfers can be ended at any time by bringing CS# HIGH when the clock is idle. The clock is not required to be free-running. The clock may remain idle while CS# is HIGH.

xSPI (octal) transaction details

4.1 Command/address/data bit assignments

Table 2 Command set^[8-12]

Command	Code	CA-Data	Address (bytes)	Latency cycles	Data (bytes)	Prerequisite
Software reset						
REST ENABLE	0x66	8-0-0	0	0	0	
RESET	0x99	8-0-0	0	0	0	RESET ENABLE
Identification						
READ ID ^[8]	0x9F	8-8-8	4 (0x00)	3-7	4	
Power modes						
DEEP POWER DOWN	0xB9	8-0-0	0	0	0	
Read memory array						
READ (DDR)	0xEE	8-8-8	4	3-7	1 to ∞	
Write memory array						
WRITE (DDR)	0xDE	8-8-8	4	3-7	1 to ∞	WRITE ENABLE
Write enable / disable						
WRITE ENABLE	0x06	8-0-0	0	0	0	
WRITE DISABLE	0x04	8-0-0	0	0	0	
Read registers						
READ ANY REGISTER	0x65	8-8-8	4	3-7	2	
Write registers						
WRITE ANY REGISTER	0x71	8-8-8	4	0	2	WRITE ENABLE

Notes

8. The two identification registers contents are read together - identification 0 followed by identification 1.
9. Write enable provides protection against inadvertent changes to memory or register values. It sets the internal write enable latch (WEL) which allows write transactions to execute afterwards.
10. Write disable can be used to disable write transactions from execution. It resets the internal write enable latch (WEL).
11. The WEL latch stays set to '1' at the end of any successful memory write transaction. After a power down / power up sequence, or a hardware/software reset, WEL latch is cleared to '0'.
12. The internal WEL latch is cleared to '0' at the end of any successful register write transaction.

4.2 RESET ENABLE transaction

The RESET ENABLE transaction is required immediately before a RESET transaction. Any transaction other than RESET following RESET ENABLE will clear the reset enable condition and prevent a later RESET transaction from being recognized.

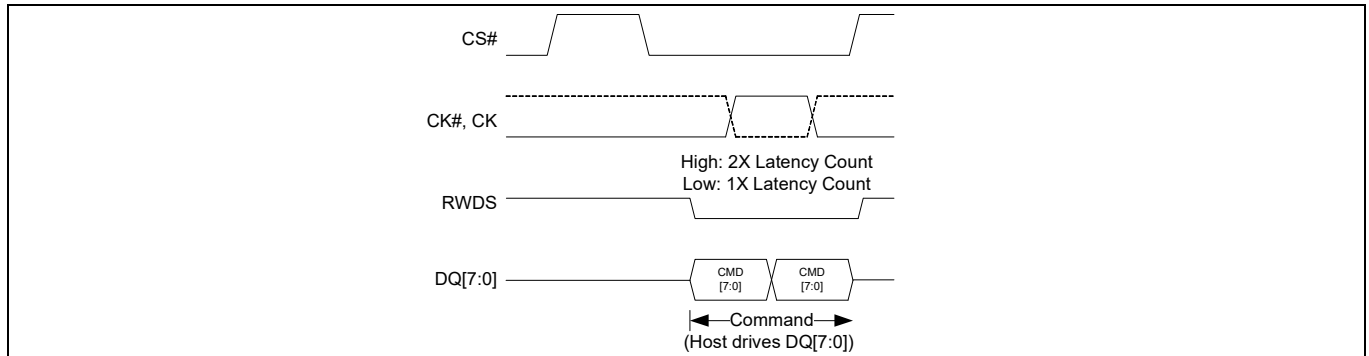

Figure 6 RESET ENABLE transaction (DDR)^[13]

4.3 RESET transaction

The RESET transaction immediately following a RESET ENABLE will initiate the software reset process. The software reset provides a software method of returning the device to the standby state. During t_{SR} (400 ns, max) the device will draw I_{CC5} current. A software reset will:

- Cause the configuration registers to return to their default values
- Halt self-refresh operation during the software reset process - memory array data is considered invalid

After software reset finishes, the self-refresh operation will resume. Because self-refresh operation is stopped, and the self-refresh row counter is reset to its default value, some rows may not be refreshed within the required array refresh interval. This may result in the loss of DRAM array data. The host system should consider DRAM array data is lost after software reset and reload any required data.

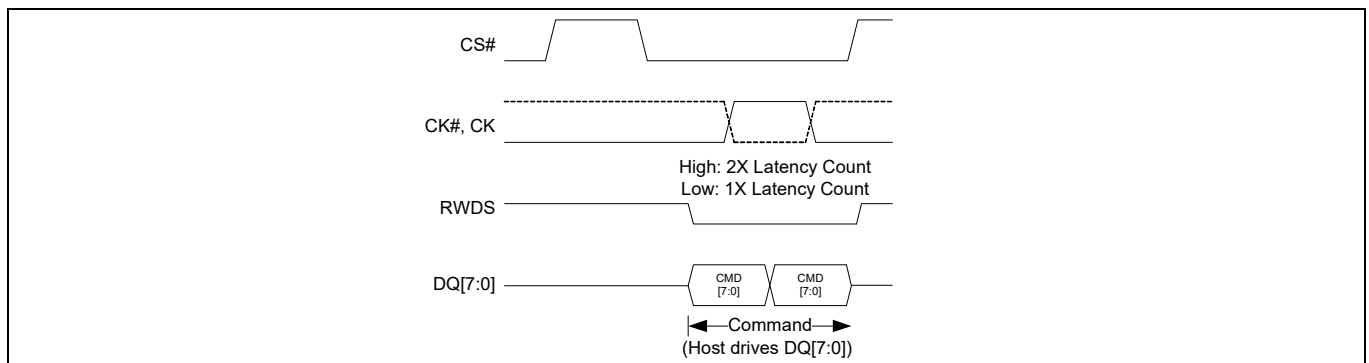

Figure 7 RESET transaction (DDR)^[13]

4.4 READ ID transaction

The READ ID transaction provides read access to device identification registers 0 and 1. The registers contain the manufacturer's identification along with device identification. The read data sequence is as follows.

Table 3 READ ID data sequence

Address space	Byte order	Byte position	Word data bit	DQ
Register 0	Big-endian	A	15	7
			14	6
			13	5
			12	4
			11	3
			10	2
			9	1
			8	0
		B	7	7
			6	6
			5	5
			4	4
			3	3
			2	2
			1	1
			0	0
Register 1	Big-endian	A	15	7
			14	6
			13	5
			12	4
			11	3
			10	2
			9	1
			8	0
		B	7	7
			6	6
			5	5
			4	4
			3	3
			2	2
			1	1
			0	0

Note

13. The initial latency “Low = 1x Latency Count” is not applicable in dual-die, 512-Mb HYPERRAM™.

xSPI (octal) transaction details

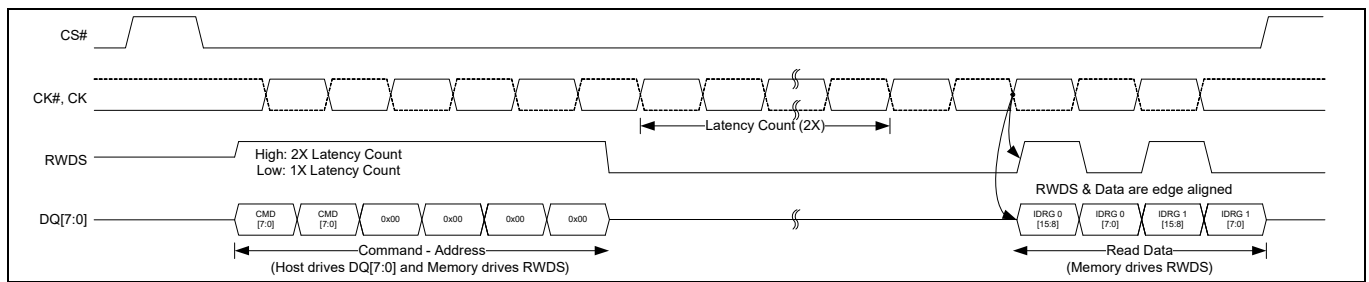

Figure 8 READ ID with 2X latency transaction (DDR)^[14]

4.5 DEEP POWER DOWN transaction

DEEP POWER DOWN transaction brings the device into Deep Power Down state which is the lowest power consumption state. Writing a “0” to CR0[15] will also bring the device in deep power down state. All register contents are lost in Deep Power Down State and the device powers-up in its default state.

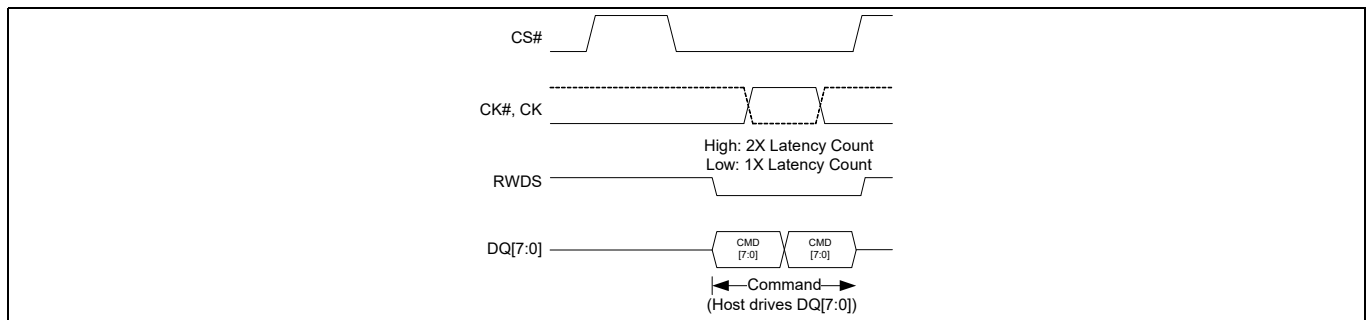

Figure 9 DEEP POWER DOWN transaction (DDR)^[14]

4.6 READ transaction

The READ transaction reads data from the memory array. It has a latency requirement (dummy cycles) which allows the device’s internal circuitry enough time to access the addressed memory location. During these latency cycles, the host can tristate the data bus DQ[7:0].

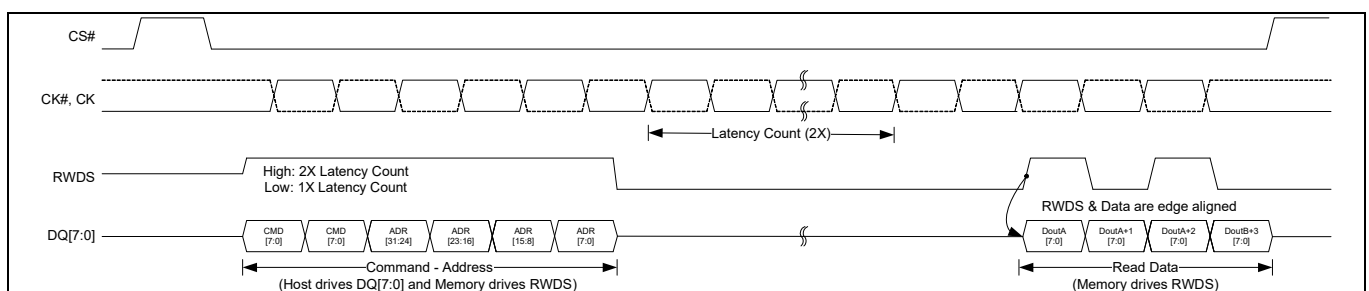

Figure 10 READ with 2X latency transaction (DDR)^[14, 15]

Notes

14. The initial latency “Low = 1x Latency Count” is not applicable in dual-die, 512-Mb HYPERRAM™.
15. RWDS is driven by HYPERRAM™ during Command and Address cycles for 2X latency and then is driven again phase aligned with data.

4.7 WRITE transaction

The WRITE transaction writes data to the memory array. It has a latency requirement (dummy cycles) which allows the device’s internal circuitry enough time to access the addressed memory location. During these latency cycles, the host can tristate the data bus DQ[7:0].

WRITE ENABLE transaction which sets the WEL latch must be executed before the first WRITE. The WEL latch stays set to ‘1’ at the end of any successful memory write transaction. It must be reset by WRITE DISABLE transaction to prevent any inadvertent writes to the memory array.

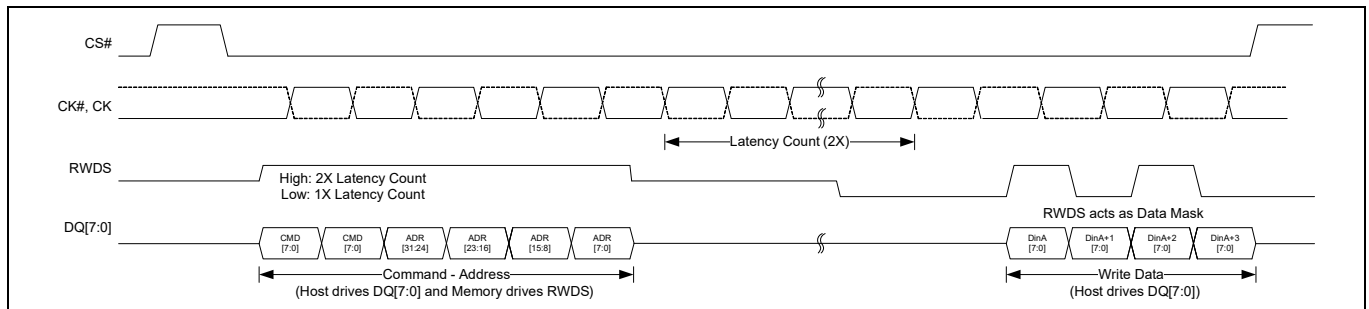

Figure 11 WRITE with 2X latency transaction (DDR)^[16, 17, 18]

4.8 WRITE ENABLE transaction

The WRITE ENABLE transaction must be executed prior to any transaction that modifies data either in the memory array or the registers.

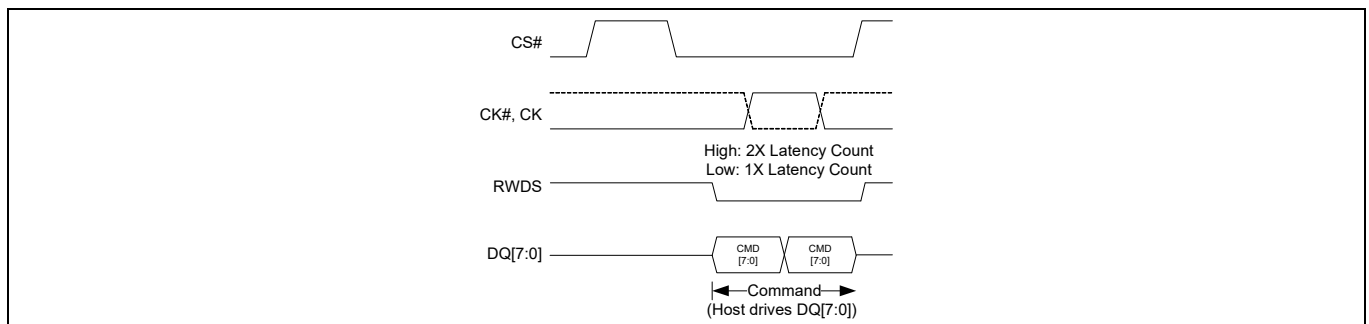

Figure 12 WRITE ENABLE transaction (DDR)^[17]

Notes

16. RWDS is driven by HYPERRAM™ during command and address cycles for 2X latency and then is driven again phase aligned with data.
17. The initial latency “Low = 1x Latency Count” is not applicable in dual-die, 512-Mb HYPERRAM™.
18. Data DinA and DinA+2 are masked.

xSPI (octal) transaction details

4.9 WRITE DISABLE Transaction

The WRITE DISABLE transaction inhibits writing data either in the memory array or the registers.

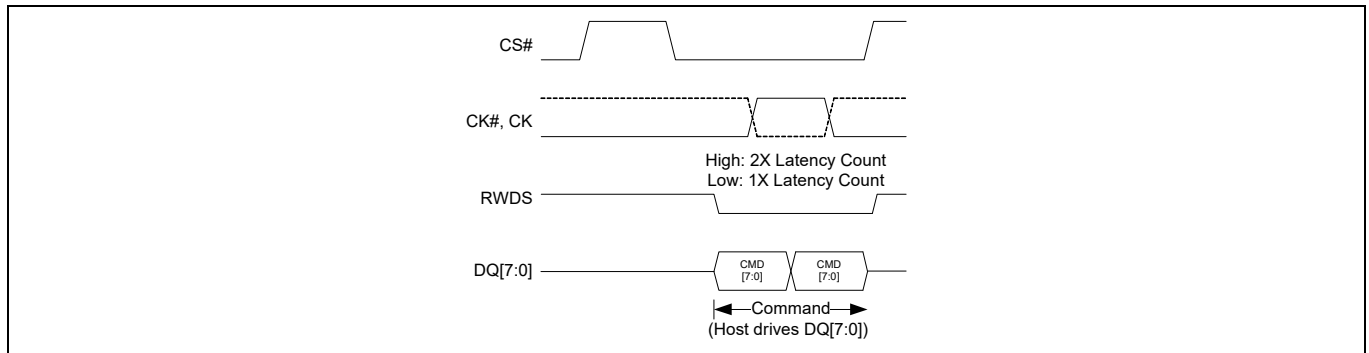

Figure 13 WRITE DISABLE transaction (DDR)^[20]

4.10 READ ANY REGISTER transaction

The READ ANY REGISTER transaction reads all the device registers. It has a latency requirement (dummy cycles) which allows the device's internal circuitry enough time to access the addressed register location. During these latency cycles, the host can tristate the data bus DQ[7:0].

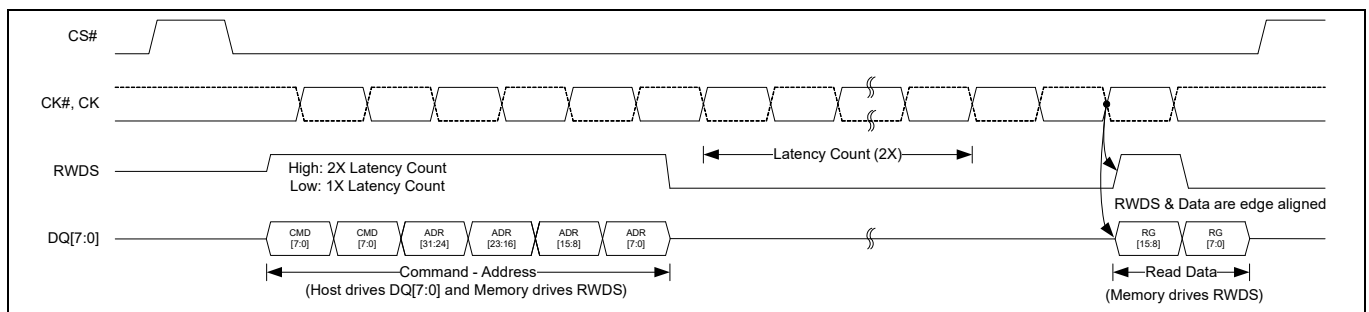

Figure 14 READ ANY REGISTER with 2X latency transaction (DDR)^[19, 20]

Notes

19. RWDS is driven by HYPERRAM™ during Command & Address cycles for 2X latency and then driven again phase aligned with data.
20. The initial latency "Low = 1x Latency Count" is not applicable in dual-die, 512-Mb HYPERRAM™.

4.11 WRITE ANY REGISTER transaction

The WRITE ANY REGISTER transaction writes to the device registers. It does not have a latency requirement (dummy cycles).

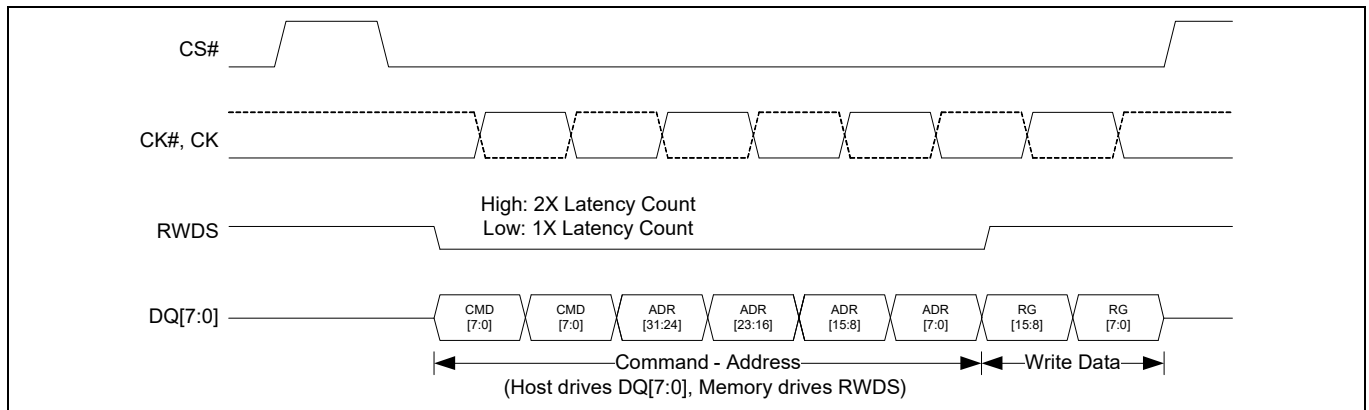

Figure 15 xSPI (octal) write with no latency transaction (DDR) (register writes)^[21-23]

Notes

21. The initial latency “Low = 1x latency count” is not applicable in dual-die, 512-Mb HYPERRAM™.
22. Write with no latency transaction is used for register writes only.
23. Data Mask on RWDS is not supported.

xSPI (octal) transaction details

4.12 Data placement during memory READ/WRITE transactions

Data placement during memory read/write is dependent upon the host. The device will output data (read) as it was written in (write). Hence both big endian and little endian are supported for the memory array.

Table 4 Data placement during memory READ and WRITE

Address space	Byte order	Byte position	Word data bit	DQ	Bit order
Memory	Big-endian	A	15	7	<p>When data is being accessed in memory space: The first byte of each word read or written is the “A” byte and the second is the “B” byte. The bits of the word within the A and B bytes depend on how the data was written. If the word lower address bits 7–0 are written in the A byte position and bits 15–8 are written into the B byte position, or vice versa, they will be read back in the same order.</p> <p>So, memory space can be stored and read in either little-endian or big-endian order.</p>
			14	6	
			13	5	
			12	4	
			11	3	
			10	2	
			9	1	
		8	0		
		B	7	7	
			6	6	
			5	5	
			4	4	
			3	3	
			2	2	
	1		1		
	0	0			
	Little-endian	A	7	7	
			6	6	
			5	5	
			4	4	
			3	3	
			2	2	
			1	1	
		0	0		
		B	15	7	
			14	6	
			13	5	
			12	4	
11			3		
10			2		
9	1				
8	0				

4.13 Data placement during register READ/WRITE transactions

Data placement during register read/write is big endian.

Table 5 Data placement during register READ/WRITE transactions

Address space	Byte order	Byte position	Word data bit	DQ	Bit order
Register	Big-endian	A	15	7	<p>When data is being accessed in register space: During a read transaction on the xSPI (octal) two bytes are transferred on each clock cycle. The upper order byte A (word[15:8]) is transferred between the rising and falling edges of RWDS (edge aligned). The lower order byte B (Word[7:0]) is transferred between the falling and rising edges of RWDS.</p> <p>During a write, the upper order byte A (Word[15:8]) is transferred on the CK rising edge and the lower order byte B (Word[7:0]) is transferred on the CK falling edge. So, register space is always read and written in Big-endian order because registers have device dependent fixed bit location and meaning definitions.</p>
			14	6	
			13	5	
			12	4	
			11	3	
			10	2	
			9	1	
			8	0	
		B	7	7	
			6	6	
			5	5	
			4	4	
			3	3	
			2	2	
			1	1	
			0	0	

Memory space

5 Memory space

5.1 xSPI (octal) interface

Table 6 Memory space address map (byte based - 8 bits with least significant bit A(0) always set to '0')

Unit type	Count	System byte address bits	Address bits	Notes
Rows within 512 Mb device	65536 (rows)	A24–A9	37–22	–
Row	64 (half-pages)	A9–A4	9–4	Each row has 64 Half-pages. Each Half-page has 16 bytes. Each column has 1K bytes.
Half-page	16 (byte addresses)	A3–A0	3–0	Half-page (HP) address is also referenced as upper column address. A word within a HP address is also referenced as lower column address. A0 always set to "0"

5.2 Density and row boundaries

The DRAM array size (density) of the device can be determined from the total number of system address bits used for the row and column addresses as indicated by the row address bit count and column address bit count fields in the ID0 register. For example: a 512-Mb HYPERRAM™ device has 10 column address bits and 16 row address bits for a total of 26 address bits (byte address) = $2^{26} = 64\text{M}$ bytes (32M words). The 10 column address bits indicate that each row holds $2^{10} = 1\text{K}$ bytes or 512 words. The row address bit count indicates there are 65536 rows to be refreshed within each array refresh interval. The row count is used in calculating the refresh interval.

6 Register space access

6.1 xSPI (octal) interface

Table 7 Register space address map (address bit A0 always set to '0')

Registers	Write/read	Address (byte addressable)
Identification registers 0 (ID0[15:0]) - die 0	Read	0x00000000
Identification registers 0 (ID0[15:0]) - die 1	Read	0x02000000
Identification registers 1 (ID1[15:0]) - die 0	Read	0x00000002
Identification registers 1 (ID1[15:0]) - die 1	Read	0x02000002
Configuration registers 0 (ID0[15:0]) - Die 0	Read	0x00000004
Configuration registers 0 (ID0[15:0]) - die 1	Read	0x02000004
Configuration registers 1 (ID1[15:0]) - die 0	Read	0x00000006
Configuration registers 1 (ID1[15:0]) - die 1	Read	0x02000006
Configuration register 0 - die 0 / 1 ^[24]	Write	0x00000004
Configuration register 1 - die 0 / 1 ^[24]	Write	0x00000006

Note

24. Register write executes write to both die at the same time.

6.2 Device identification registers

There are two read-only, nonvolatile, word registers, that provide information on the device selected when CS# is LOW. The device information fields identify:

- Manufacturer
- Type
- Density
 - Row address bit count
 - Column address bit count
- Refresh type

Table 8 Identification register 0 (ID0) bit assignments

Bits	Function	Settings (binary)
[15:14]	Reserved	00b - die 0 01b - die 1
13	Reserved	0 - default
[12:8]	Row address bit count	0000 - one row address bit ... 11111 - thirty-two row address bits ... 01111 - sixteen row address bits (512 Mb)
[7:4]	Column address bit count	0000 - one column address bits ... 1001 - ten column address bits (default) ... 1111 - sixteen column address bits
[3:0]	Manufacturer	0110b

ID0 value for S80KS5123 is 0x0E96 if read from Die 0 or 0x4F96 if read from Die 1. Refer to [Table 7](#) for register map of each die.

Table 9 Identification register 1 (ID1) bit assignments

Bits	Function	Settings (Binary)
[15:4]	Reserved	0000_0000_0000 (default)
[3:0]	Device type	0001 - HYPERRAM™ 2.0

6.3 Device configuration registers

6.3.1 Configuration register 0 (CR0)

Configuration register 0 (CR0) is used to define the power state and access protocol operating conditions for the HYPERRAM™ device. Configurable characteristics include:

- Wrapped burst length (16, 32, 64, or 128 byte aligned and length data group)
- Wrapped burst type
 - Legacy wrap (sequential access with wrap around within a selected length and aligned group)
 - Hybrid wrap (Legacy wrap once then linear burst at start of the next sequential group)
- Initial latency
- Variable latency
 - Whether an array read or write transaction will use fixed or variable latency. If fixed latency is selected the memory will always indicate a refresh latency and delay the read data transfer accordingly. If variable latency is selected, latency for a refresh is only added when a refresh is required at the same time a new transaction is starting.
- Output drive strength
- Deep power down (DPD) mode

Register space access

Table 10 Configuration register 0 (CR0) bit assignments

CR0 bit	Function	Settings (binary)
[15]	Deep power down enable	1 - Normal operation (default). HYPERRAM™ will automatically set this value to '1' after DPD exit 0 - Writing 0 causes the device to enter deep power down Device automatically sets the value of CR0[15] to '1' after exit DPD.
[14:12]	Drive strength	000 - 34 ohms (default) 001 - 115 ohms 010 - 67 ohms 011 - 46 ohms 100 - 34 ohms 101 - 27 ohms 110 - 22 ohms 111 - 19 ohms
[11:8]	Reserved	1 - Reserved (default) Reserved for future use. When writing this register, these bits should be set to 1 for future compatibility.
[7:4]	Initial latency	0000 - 5 clock latency @ 133 MHz Max frequency 0001 - 6 clock latency @ 166 MHz Max frequency 0010 - 7 clock latency @ 200 MHz Max frequency (default) 0011 - Reserved 0100 - Reserved ... 1101 - reserved 1110 - 3 clock latency @ 85 Max frequency 1111 - 4 clock latency @ 104 Max frequency
[3]	Fixed latency enable	0 - reserved 1 - fixed 2 times initial latency (default) The 512-Mb dual-die stack only supports fixed latency. In fixed latency mode, when CS# asserted LOW, 1. The RWDS signal of each die of dual-die 512-Mb will always drive to HIGH during CA phase. 2. The RWDS signal of the non-selected die of dual-die 512-Mb will always drive to Hi-Z after CA phase. 3. The RWDS signal of the selected die of dual-die 512-Mb will drive to L after CA phase.
[2]	Hybrid burst enable	0: Wrapped burst sequence to follow hybrid burst sequencing 1: Wrapped burst sequence in legacy wrapped burst manner (default) This bit setting is effective only when the "Burst Type" bit in the Command/Address register is set to '0', i.e. CA[45] = '0'; otherwise, it is ignored.
[1:0]	Burst length	00 - 128 bytes 01 - 64 bytes 10 - 16 bytes 11 - 32 bytes (default)

Register space access

Wrapped burst

A wrapped burst transaction accesses memory within a group of words aligned on a word boundary matching the length of the configured group. Wrapped access groups can be configured as 16, 32, 64, or 128 bytes alignment and length. During wrapped transactions, access starts at the CA selected location within the group, continues to the end of the configured word group aligned boundary, then wraps around to the beginning location in the group, then continues back to the starting location. Wrapped bursts are generally used for critical word first instruction or data cache line fill read accesses. Wrapped burst across die boundary is not supported.

Hybrid burst

The beginning of a hybrid burst will wrap within the target address wrapped burst group length before continuing to the next half-page of data beyond the end of the wrap group. Continued access is in linear burst order until the transfer is ended by returning CS# HIGH. This hybrid of a wrapped burst followed by a linear burst starting at the beginning of the next burst group, allows multiple sequential address cache lines to be filled in a single access. The first cache line is filled starting at the critical word. Then the next sequential line in memory can be read in to the cache while the first line is being processed. Hybrid burst across die boundary is not supported.

Table 11 CR0[2] control of wrapped burst sequence

Bit	Default value	Setting details
CR0[2]	1b	Hybrid Burst Enable CR0[2] = 0: Wrapped burst sequence to follow hybrid burst sequencing CR0[2] = 1: Wrapped burst sequence in legacy wrapped burst manner

Table 12 Example wrapped burst sequences (addressing)

Burst type	Wrap boundary (bytes)	Start address (hex)	Sequence of byte addresses (hex) of data words
Hybrid 128	128 wrap once then linear	XXXXXX03	03, 04, 05, 06, 07, 08, 09, 0A, 0B, 0C, 0D, 0E, 0F, 10, 11, 12, 13, 14, 15, 16, 17, 18, 19, 1A, 1B, 1C, 1D, 1E, 1F, 20, 21, 22, 23, 24, 25, 26, 27, 28, 29, 2A, 2B, 2C, 2D, 2E, 2F, 30, 31, 32, 33, 34, 35, 36, 37, 38, 39, 3A, 3B, 3C, 3D, 3E, 3F, 00, 01, 02 (Wrap complete, now linear beyond the end of the initial 128 byte wrap group) 40, 41, 42, 43, 44, 45, 46, 47, 48, 49, 4A, 4B, 4C, 4D, 4E, 4F, 50, 51, ...
Hybrid 64	64 wrap once then linear	XXXXXX02	02, 04, 06, 08, 0A, 0C, 0E, 10, 12, 14, 16, 18, 1A, 1C, 1E, 20, 22, 24, 26, 28, 2A, 2C, 2E, 30, 32, 34, 36, 38, 3A, 3C, 3E, 00 (wrap complete, now linear beyond the end of the initial 64 byte wrap group) 40, 42, 44, 46, 48, 4A, 4C, 4E, 50, 52, ...
Hybrid 64	64 wrap once then linear	XXXXXX2E	2E, 30, 32, 34, 36, 38, 3A, 3C, 3E, 00, 02, 04, 06, 08, 0A, 0C, 0E, 10, 12, 14, 16, 18, 1A, 1C, 1E, 20, 22, 24, 26, 28, 2A, 2C (wrap complete, now linear beyond the end of the initial 64 byte wrap group) 40, 42, 44, 46, 48, 4A, 4B, 4C, 4D, 4E, 4F, 50, 52, ...
Hybrid 16	16 wrap once then linear	XXXXXX02	02, 04, 06, 08, 0A, 0C, 0E, 00 (wrap complete, now linear beyond the end of the initial 16 byte wrap group) 10, 12, 14, 16, 18, 1A, ..
Hybrid 16	16 wrap once then linear	XXXXXX0C	0C, 0E, 00, 02, 04, 06, 08, 0A (wrap complete, now linear beyond the end of the initial 16 byte wrap group) 10, 12, 14, 16, 18, 1A, ...

Register space access

Table 12 Example wrapped burst sequences (addressing) (Continued)

Burst type	Wrap boundary (bytes)	Start address (hex)	Sequence of byte addresses (hex) of data words
Hybrid 32	32 wrap once then linear	XXXXXX0A	0A, 0C, 0E, 10, 12, 14, 16, 18, 1A, 1C, 1E, 00, 02, 04, 06, 08 (wrap complete, now linear beyond the end of the initial 32 byte wrap group) 20, 22, 24, 26, 28, 2A, ...
Wrap 64	64	XXXXXX02	02, 04, 06, 08, 0A, 0C, 0E, 10, 12, 14, 16, 18, 1A, 1C, 1E, 20, 22, 24, 26, 28, 2A, 2C, 2E, 30, 32, 34, 36, 38, 3A, 3C, 3E, 00, ...
Wrap 64	64	XXXXXX2E	2E, 30, 32, 34, 36, 38, 3A, 3C, 3E, 00, 02, 04, 06, 08, 0A, 0C, 0E, 10, 12, 14, 16, 18, 1A, 1C, 1E, 20, 22, 24, 26, 28, 2A, 2C, 2E, 30, ...
Wrap 16	16	XXXXXX02	02, 04, 06, 08, 0A, 0C, 0E, 00, ...
Wrap 16	16	XXXXXX0C	0C, 0E, 00, 02, 04, 06, 08, 0A, ...
Wrap 32	32	XXXXXX0A	0A, 0C, 0E, 10, 12, 14, 16, 18, 1A, 1C, 1E, 00, 02, 04, 06, 08, ...
Linear	Linear burst	XXXXXX02	02, 04, 06, 08, 0A, 0C, 0E, 10, 12, 14, 16, 18, 1A, 1C, 1E, 20, 22, ...

Initial latency

Memory space read and write transactions or register space read transactions require some initial latency to open the row selected by the CA. This initial latency is t_{ACC} . The number of latency clocks needed to satisfy t_{ACC} depends on the clock input frequency can vary from 3 to 7 clocks. The value in CR0[7:4] selects the number of clocks for initial latency. The default value is 7 clocks, allowing for operation up to a maximum frequency of 200MHz prior to the host system setting a lower initial latency value that may be more optimal for the system.

In the event a distributed refresh is required at the time a memory space read or write transaction or register space read transaction begins, the RWDS signal goes High during the CA to indicate that an additional initial latency is being inserted to allow a refresh operation to complete before opening the selected row.

Register space write transactions always have zero initial latency. RWDS may be HIGH or LOW during the CA period. The level of RWDS during the CA period does not affect the placement of register data immediately after the CA, as there is no initial latency needed to capture the register data. A refresh operation may be performed in the memory array in parallel with the capture of register data.

Fixed latency

A configuration register option bit CR0[3] is provided to make all memory space read and write transactions or register space read transactions require the same initial latency by always driving RWDS HIGH during the CA to indicate that two initial latency periods are required. This fixed initial latency is independent of any need for a distributed refresh, it simply provides a fixed (deterministic) initial latency for all of these transaction types. Fixed latency is the default POR or reset configuration.

Drive strength

DQ and RWDS signal line loading, length, and impedance vary depending on each system design. Configuration register bits CR0[14:12] provide a means to adjust the DQ[7:0] and RWDS signal output impedance to customize the DQ and RWDS signal impedance to the system conditions to minimize high speed signal behaviors such as overshoot, undershoot, and ringing. The default POR or reset configuration value is 000b to select the mid point of the available output impedance options.

The impedance values shown are typical for both pull-up and pull-down drivers at typical silicon process conditions, nominal operating voltage (1.8 V) and 50 °C. The impedance values may vary from the typical values depending on the process, voltage, and temperature (PVT) conditions. Impedance will increase with slower process, lower voltage, or higher temperature. Impedance will decrease with faster process, higher voltage, or lower temperature.

Each system design should evaluate the data signal integrity across the operating voltage and temperature ranges to select the best drive strength settings for the operating conditions.

Register space access

Deep power down

When the HYPERRAM™ device is not needed for system operation, it may be placed in a very low power consuming state called Deep Power Down (DPD), by writing 0 to CR0[15]. When CR0[15] is cleared to 0, the device enters the DPD state within t_{DPDIN} time and all refresh operations stop. The data in RAM is lost, (becomes invalid without refresh) during DPD state. Exiting DPD requires driving CS# LOW then HIGH, POR, or a reset. Only CS# and RESET# signals are monitored during DPD mode. For additional details, see “Deep power down” on page 31.

6.3.2 Configuration register 1

Configuration register 1 (CR1) is used to define the refresh array size, refresh rate and hybrid sleep for the HYPERRAM™ device. Configurable characteristics include:

- Partial array refresh
- Hybrid sleep state
- Refresh rate

Table 13 Configuration register 1 (CR1) bit assignments

CR1 bit	Function	Setting (binary)
[15:8]	Reserved	11111111 - reserved (default) When writing this register, these bits should keep 0xFFh for future compatibility.
[7]	Burst type	1 - linear burst (default) 0 - wrapped burst
[6]	Master clock type	1 - single ended - CK (default) 0 - differential - CK#, CK
[5]	Hybrid sleep	1 - causes the device to enter hybrid sleep State 0 - normal operation (default)
[4:2]	Partial array refresh	000 - full array (default) 001 - bottom 1/2 Array 010 - bottom 1/4 Array 011 - bottom 1/8 Array 100 - none 101 - top 1/2 Array 110 - top 1/4 Array 111 - top 1/8 Array
[1:0]	Distributed refresh interval (read only)	10 - 1 μ s t_{CSM} (Industrial Plus temperature range devices) 11 - reserved 00 - reserved 01 - 4 μ s t_{CSM} (Industrial temperature range devices)

Burst type

Two burst types, namely linear and wrapped, are supported in xSPI (Octal) mode by HYPERRAM™. CR1[7] selects which type to use.

Master clock type

Two clock types, namely single ended and differential, are supported. CR1[6] selects which type to use.

- In the single ended clock mode (by default), CK# input is not enabled; hence it may be left either floating or biased to HIGH or LOW.
- In the differential clock mode (when enabled), the CK# input can't be left floating. It must be either driven by the host, or biased to HIGH or LOW.

Register space access

Partial array refresh

The partial array refresh configuration restricts the refresh operation in HYPERRAM™ to a portion of the memory array specified by CR1[5:3]. This reduces the standby current. The default configuration refreshes the whole array.

Hybrid sleep (HS)

When the HYPERRAM™ is not needed for system operation but data in the device needs to be retained, it may be placed in Hybrid Sleep state to save more power. Enter hybrid sleep state by writing 1 to CR1[5]. Bringing CS# LOW will cause the device to exit HS state and set CR1[5] to 0. Also, POR, or a hardware reset will cause the device to exit Hybrid Sleep state. Note that a POR or a hardware reset disables refresh where the memory core data can potentially get lost.

Distributed refresh interval

The HYPERRAM™ device is built with volatile DRAM array which requires periodic refresh of all bits in it. The refresh operation can be done by an internal self-refresh logic that will evenly refresh the memory array automatically. The automatic refresh operation can only be done when the memory array is not actively read or written by the host system. The refresh logic waits for the end of any active read or write before doing a refresh, if a refresh is needed at that time. If a new read or write begins before the refresh is completed, the memory will drive RWDS high during the CA period to indicate that an additional initial latency time is required at the start of the new access in order to allow the refresh operation to complete before starting the new access. The evenly distributed refresh operations require a maximum refresh interval between two adjacent refresh operations. The maximum distributed refresh interval varies with temperature as shown in [Table 14](#).

Table 14 Array refresh interval per temperature

Operating temperature	Refresh interval t_{CSM}	CR1[1:0]
$T_A \leq 85\text{ }^\circ\text{C}$	4 μs	01b
$85\text{ }^\circ\text{C} < T_A \leq 125\text{ }^\circ\text{C}$	1 μs	10b

The distributed refresh operation requires that the host does not perform burst transactions longer than the distributed refresh interval to prevent the memory from unable doing the distributed refreshes operation when it is needed. This sets an upper limit on the length of read and write transactions so that the automatic distributed refresh operation can be done between transactions. This limit is called the CS# low maximum time (t_{CSM}) and the t_{CSM} will be equal to the maximum distributed refresh interval. The host system is required to respect the t_{CSM} value by terminating each transaction before violating t_{CSM} . This can be done by host memory controller splitting long transactions when reaching the t_{CSM} limit, or by host system hardware or software not performing a single burst read or write transaction that would be longer than t_{CSM} .

As noted in [Table 14](#), the maximum refresh interval is longer at lower temperatures such that t_{CSM} could be increased to allow longer transactions. The host may determine the operating temperature from a temperature sensor in the system and use the t_{CSM} value from the table accordingly, or it may determine dynamically by reading the read only CR1[1:0] bits in order to set the distributed refresh interval prior to the HYPERRAM™ access.

7 Interface states

Table 15 describes the required value of each signal for each interface state.

Table 15 Interface states

Interface state	V_{CC}/V_{CCQ}	CS#	CK, CK#	DQ7-DQ0	RWDS	RESET#
Power-off	$< V_{LKO}$	X	X	HIGH-Z	HIGH-Z	X
Power-on (cold) reset	$\geq V_{CC}/V_{CCQ} \text{ min}$	X	X	HIGH-Z	HIGH-Z	X
Hardware (warm) reset	$\geq V_{CC}/V_{CCQ} \text{ min}$	X	X	HIGH-Z	HIGH-Z	L
Interface standby	$\geq V_{CC}/V_{CCQ} \text{ min}$	H	X	HIGH-Z	HIGH-Z	H
CA	$\geq V_{CC}/V_{CCQ} \text{ min}$	L	T	Master output valid	Y	H
Read initial access latency (data bus turn around period)	$\geq V_{CC}/V_{CCQ} \text{ min}$	L	T	HIGH-Z	L	H
Write initial access latency (RWDS turn around period)	$\geq V_{CC}/V_{CCQ} \text{ min}$	L	T	HIGH-Z	HIGH-Z	H
Read data transfer	$\geq V_{CC}/V_{CCQ} \text{ min}$	L	T	Slave output valid	Slave output valid Z or T	H
Write data transfer with initial latency	$\geq V_{CC}/V_{CCQ} \text{ min}$	L	T	Master output valid	Master output valid X or T	H
Write data transfer without initial latency ^[25]	$\geq V_{CC}/V_{CCQ} \text{ min}$	L	T	Master output valid	Slave output L or HIGH-Z	H
Active clock stop ^[26]	$\geq V_{CC}/V_{CCQ} \text{ min}$	L	Idle	Master or slave output valid or HIGH-Z	Y	H
Deep power down	$\geq V_{CC}/V_{CCQ} \text{ min}$	H	X or T	HIGH-Z	HIGH-Z	H
Hybrid sleep	$\geq V_{CC}/V_{CCQ} \text{ min}$	H	X or T	HIGH-Z	HIGH-Z	H

Legend

L = V_{IL} ; H = V_{IH} ; X = Either V_{IL} or V_{IH} ; Y = Either V_{IL} or V_{IH} or V_{OL} or V_{OH} ; Z = Either V_{OL} or V_{OH} ; L/H = Rising edge; H/L = Falling edge; T = Toggling during information transfer; Idle = CK is LOW and CK# is HIGH; Valid = All bus signals have stable L or H level

Notes

- Writes without initial latency (with zero initial latency), do not have a turn around period for RWDS. The HYPERRAM™ device will always drive RWDS during the CA period to indicate whether extended latency is required. Since master write data immediately follows the CA period the HYPERRAM™ device may continue to drive RWDS LOW or may take RWDS to HIGH-Z. The master must not drive RWDS during Writes with zero latency. Writes with zero latency do not use RWDS as a data mask function. All bytes of write data are written (full word writes).
- Active Clock Stop is described in “Active clock stop” on page 29. DPD is described in “Deep power down” on page 31.

8 Power conservation modes

8.1 Interface standby

Standby is the default, low power, state for the interface while the device is not selected by the host for data transfer (CS# = HIGH). All inputs, and outputs other than CS# and RESET# are ignored in this state.

8.2 Active clock stop

Design Note: Active clock stop feature is pending device characterization to determine if it will be supported.

The active clock stop state reduces device interface energy consumption to the I_{CC6} level during the data transfer portion of a read or write operation. The device automatically enables this state when clock remains stable for $t_{ACC} + 30$ ns. While in Active Clock Stop state, read data is latched and always driven onto the data bus. I_{CC6} shown in “DC characteristics” on page 34.

Active clock stop state helps reduce current consumption when the host system clock has stopped to pause the data transfer. Even though CS# may be LOW throughout these extended data transfer cycles, the memory device host interface will go into the active clock stop current level at $t_{ACC} + 30$ ns. This allows the device to transition into a lower current state if the data transfer is stalled. Active read or write current will resume once the data transfer is restarted with a toggling clock. The active clock stop state must not be used in violation of the t_{CSM} limit. CS# must go HIGH before t_{CSM} is violated. Clock can be stopped during any portion of the active transaction as long as it is in the LOW state. Note that it is recommended to avoid stopping the clock during register access.

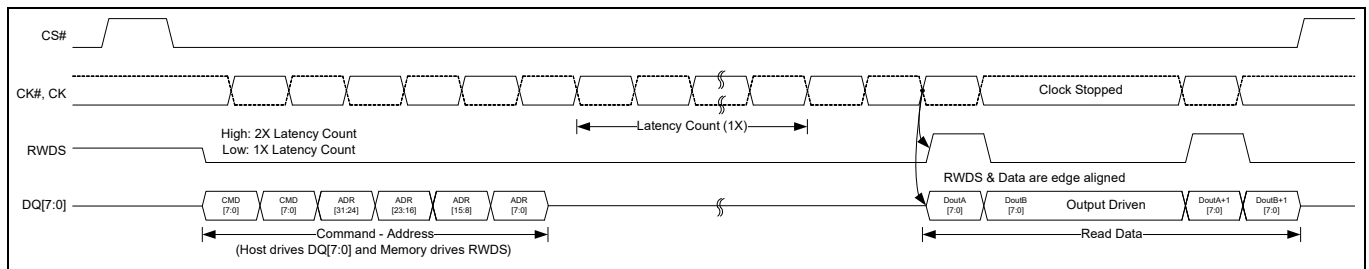

Figure 16 Active clock stop during read transaction (DDR)

8.3 Hybrid sleep

In the hybrid sleep (HS) state, the current consumption is reduced (I_{HS}). HS state is entered by writing a 1 to CR1[5]. The device reduces power within t_{HSIN} time. The data in memory space and register space is retained during HS state. Bringing CS# LOW will cause the device to exit HS state and set CR1[5] to 0. Also, POR, or a hardware reset will cause the device to exit hybrid sleep state. Note that a POR or a hardware reset disables refresh where the memory core data can potentially get lost. Returning to standby state requires t_{EXITHS} time. Following the exit from HS due to any of these events, the device is in the same state as entering hybrid sleep.

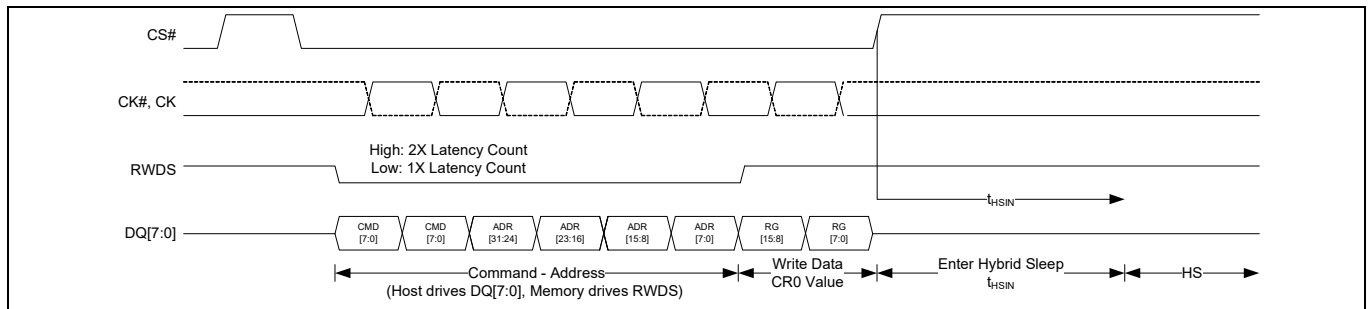

Figure 17 Enter HS transaction^[27]

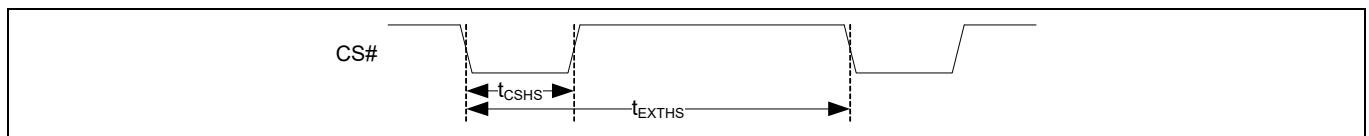

Figure 18 Exit HS transaction

Table 16 Hybrid sleep timing parameters

Parameter	Description	Min	Max	Unit
t_{HSIN}	Hybrid sleep CR1[5] = 0 register write to DPD power level	–	3	μ s
t_{CSHS}	CS# pulse width to exit HS	60	3000	ns
t_{EXTHS}	CS# exit hybrid sleep to standby wakeup time	–	100	μ s

Note

27. The initial latency “Low = 1x latency count” is not applicable in dual-die, 512-Mb HYPERRAM™. Write with no latency transaction is used for register writes only.

8.4 Deep power down

In the deep power down (DPD) state, current consumption is driven to the lowest possible level (I_{DPD}). DPD state is entered by writing a 0 to CR0[15]. The device reduces power within t_{DPDIN} time and all refresh operations stop. The data in memory space is lost, (becomes invalid without refresh) during DPD state. Driving CS# LOW then HIGH will cause the device to exit DPD state. Also, POR, or a hardware reset will cause the device to exit DPD state. Returning to standby state requires t_{EXTDPD} time. Returning to standby state following a POR requires t_{VCS} time, as with any other POR. Following the exit from DPD due to any of these events, the device is in the same state as following POR.

Note In xSPI (Octal), deep power down transaction or write any register transaction can be used to enter DPD.

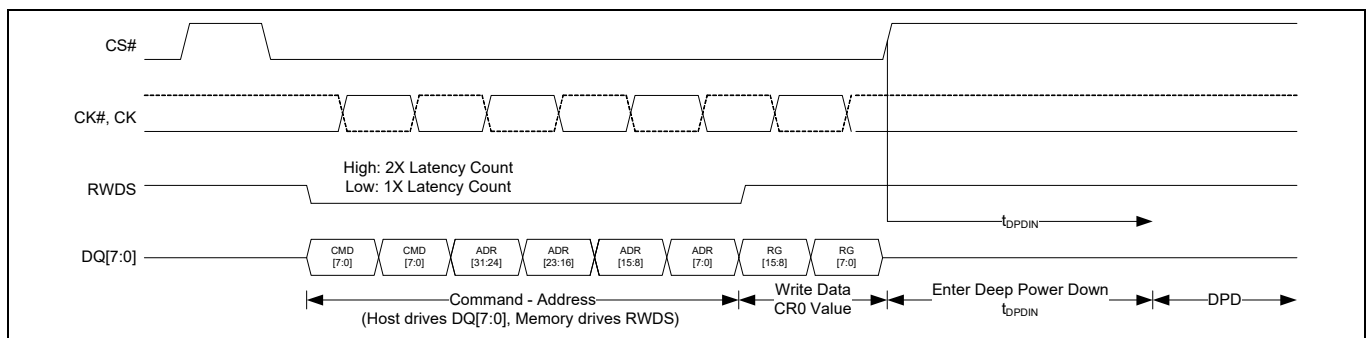

Figure 19 Enter DPD transaction^[28]

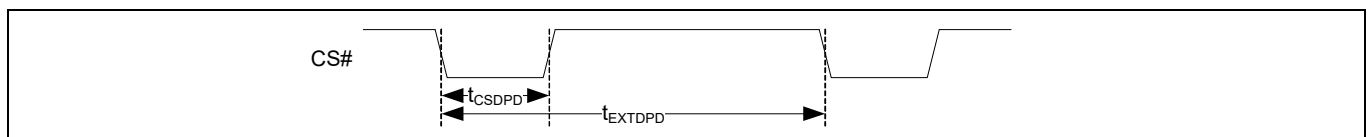

Figure 20 Exit DPD transaction

Table 17 Deep power down timing parameters

Parameter	Description	Min	Max	Unit
t_{DPDIN}	Deep power down CR0[15] = 0 register write to DPD power level	–	3	μ s
t_{CSDPD}	CS# pulse width to exit DPD	200	3000	ns
t_{EXTDPD}	CS# exit deep power down to standby wakeup time	–	150	μ s

Note

28. The initial latency “Low = 1x latency count” is not applicable in dual-die, 512-Mb HYPERRAM™. Write with no latency transaction is used for register writes only.

9 Electrical specifications

9.1 Absolute maximum ratings

Storage temperature plastic packages	-65 °C to +150 °C
Ambient temperature with power applied	-65 °C to +135 °C
Voltage with respect to ground All signals ^[29]	-0.5 V to + (V _{CC} + 0.5 V)
Output short circuit current ^[30]	100 mA
Voltage on V _{CC} , V _{CCQ} pins relative to V _{SS}	-0.5 V to +2.5 V
Electrostatic discharge voltage:	
Human body model (JEDEC Std JESD22-A114-B)	2000 V
Charged device model (JEDEC Std JESD22-C101-A)	500 V

9.2 Input signal overshoot

During DC conditions, input or I/O signals should remain equal to or between V_{SS} and V_{CC}. During voltage transitions, inputs or I/Os may negative overshoot V_{SS} to -1.0 V or positive overshoot to V_{CC} + 1.0 V, for periods up to 20 ns.

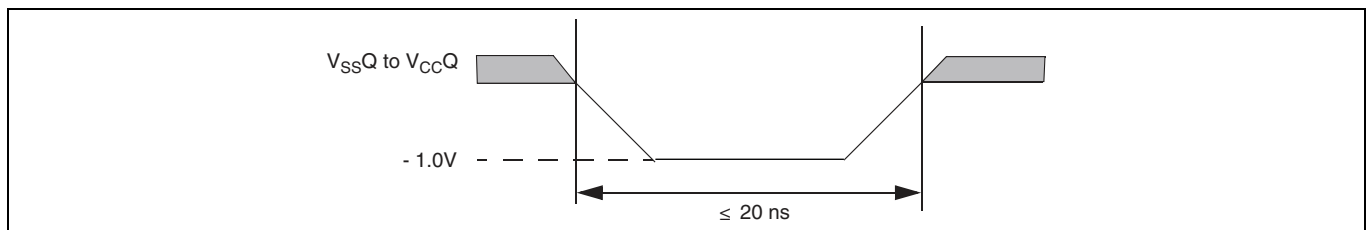

Figure 21 Maximum negative overshoot waveform

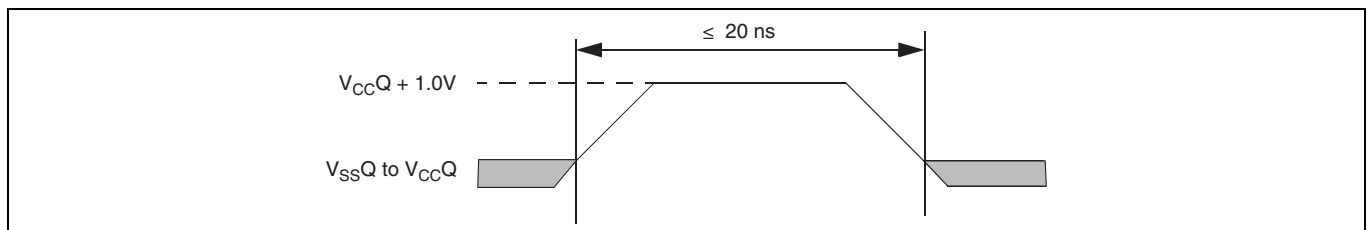

Figure 22 Maximum positive overshoot waveform

Notes

29. Minimum DC voltage on input or I/O signal is -1.0V. During voltage transitions, input or I/O signals may undershoot V_{SS} to -1.0V for periods of up to 20 ns. See [Figure 21](#). Maximum DC voltage on input or I/O signals is V_{CC} + 1.0V. During voltage transitions, input or I/O signals may overshoot to V_{CC} + 1.0V for periods up to 20 ns. See [Figure 22](#).
30. No more than one output may be shorted to ground at a time. Duration of the short circuit should not be greater than one second.
31. Stresses above those listed under “[Absolute maximum ratings](#)” on page 32 may cause permanent damage to the device. This is a stress rating only; functional operation of the device at these or any other conditions above those indicated in the operational sections of this data sheet is not implied. Exposure of the device to absolute maximum rating conditions for extended periods may affect device reliability.

Electrical specifications

9.3 Latch-up characteristics

9.3.1 Latch-up specification

Table 18 Latch-up specification^[32]

Description	Min	Max	Unit
Input voltage with respect to V_{SSQ} on all input only connections	-1.0	$V_{CCQ} + 1.0$	V
Input voltage with respect to V_{SSQ} on all I/O connections	-1.0	$V_{CCQ} + 1.0$	
V_{CCQ} current	-100	+100	mA

9.4 Operating ranges

Operating ranges define those limits between which the functionality of the device is guaranteed.

9.4.1 Temperature ranges

Table 19 Temperature ranges

Parameter	Symbol	Device	Spec		Unit
			Min	Max	
Ambient temperature	T_A	Industrial (I)	-40	85	°C
		Industrial Plus (V)	-40	105	
		Automotive, AEC-Q100 Grade 3 (A)	-40	85	
		Automotive, AEC-Q100 Grade 2 (B)	-40	105	
		Automotive, AEC-Q100 Grade 1 (M)	-40	125	

9.4.2 Power supply voltages

Table 20 Power supply voltages

Description	Min	Max	Unit
V_{CC} power supply	1.7	2.0	V

Note

32. Excludes power supplies V_{CC}/V_{CCQ} . Test conditions: $V_{CC} = V_{CCQ}$, one connection at a time tested, connections not being tested are at V_{SS} .

Electrical specifications

9.5 DC characteristics

Table 21 DC Characteristics (CMOS compatible)

Parameter	Description	Test conditions	512 Mb			Unit
			Min	Typ ^[33]	Max	
I_{LI2}	Input leakage current device reset signal HIGH	$V_{IN} = V_{SS}$ to V_{CC} , $V_{CC} = V_{CC}$ max	-	-	4	μA
I_{LI4}	Input leakage current device reset signal LOW ^[34]	$V_{IN} = V_{SS}$ to V_{CC} , $V_{CC} = V_{CC}$ max	-	-	30	
I_{CC1}	V_{CC} active read current operating temperature range	$CS\# = V_{SS}$, CK @ 200 MHz, $V_{CC} = V_{CC}$ max	-	28	40	mA
I_{CC2}	V_{CC} active write current operating temperature range		-	32	44	
I_{CC4}	V_{CC} standby current (-40 °C to +85 °C)	$CS\# = V_{CC}$, $V_{CC} = 2.0$ V; full array	-	940	2400	μA
		$CS\# = V_{CC}$, $V_{CC} = 2.0$ V; bottom 1/2 array	-		1700	
		$CS\# = V_{CC}$, $V_{CC} = 2.0$ V; bottom 1/4 array	-		1400	
		$CS\# = V_{CC}$, $V_{CC} = 2.0$ V; bottom 1/8 array	-		1200	
		$CS\# = V_{CC}$, $V_{CC} = 2.0$ V; top 1/2 array	-		1700	
		$CS\# = V_{CC}$, $V_{CC} = 2.0$ V; top 1/4 array	-		1400	
		$CS\# = V_{CC}$, $V_{CC} = 2.0$ V; top 1/8 array	-		1200	
	V_{CC} standby current (-40 °C to +105 °C)	$CS\# = V_{CC}$, $V_{CC} = 2.0$ V; full array	-	940	3100	
		$CS\# = V_{CC}$, $V_{CC} = 2.0$ V; bottom 1/2 array	-		2300	
		$CS\# = V_{CC}$, $V_{CC} = 2.0$ V; bottom 1/4 array	-		1900	
		$CS\# = V_{CC}$, $V_{CC} = 2.0$ V; bottom 1/8 array	-		1700	
		$CS\# = V_{CC}$, $V_{CC} = 2.0$ V; top 1/2 array	-		2300	
		$CS\# = V_{CC}$, $V_{CC} = 2.0$ V; top 1/4 array	-		1900	
		$CS\# = V_{CC}$, $V_{CC} = 2.0$ V; top 1/8 array	-		1700	

Notes

33. Not 100% tested.

34. RESET# LOW initiates exits from DPD and hybrid sleep state and initiates the draw of I_{CC5} reset current, making I_{LI} during RESET# LOW insignificant.

Electrical specifications

Table 21 DC Characteristics (CMOS compatible) (Continued)

Parameter	Description	Test conditions	512 Mb			Unit
			Min	Typ ^[33]	Max	
I _{CC4}	V _{CC} standby current (-40 °C to +125 °C)	CS# = V _{CC} , V _{CC} = V _{CC} max; full array	-	940	4000	μA
		CS# = V _{CC} , V _{CC} = V _{CC} max; bottom 1/2 array	-		3100	
		CS# = V _{CC} , V _{CC} = V _{CC} max; bottom 1/4 array	-		2500	
		CS# = V _{CC} , V _{CC} = V _{CC} max; bottom 1/8 array	-		2200	
		CS# = V _{CC} , V _{CC} = V _{CC} max; top 1/2 array	-		3100	
		CS# = V _{CC} , V _{CC} = V _{CC} max; top 1/4 array	-		2500	
		CS# = V _{CC} , V _{CC} = V _{CC} max; top 1/8 array	-		2200	
I _{CC5}	Reset current (-40 °C to +85 °C)	CS# = V _{CC} , RESET# = V _{SS} , V _{CC} = V _{CC} max	-	-	1.6	mA
	Reset current (-40 °C to +105 °C)		-	-	2	
	Reset current (-40 °C to +125 °C)		-	-	3	
I _{CC6}	Active clock stop current (-40 °C to +85 °C)	CS# = V _{SS} , RESET# = V _{CC} , V _{CC} = V _{CC} max	-	25	38	mA
	Active clock stop current (-40 °C to +105 °C)		-		45	
	Active clock stop current (-40 °C to +125 °C)		-		60	
I _{CC7}	V _{CC} current during power up ^[34]	CS# = V _{CC} , V _{CC} = V _{CC} max, V _{CCQ} = V _{CC}	-	-	70	
I _{DPD} ^[34]	Deep power down current (-40 °C to +85 °C)	CS# = V _{CC} , V _{CC} = V _{CC} max	-	-	20	μA
	Deep power down current (-40 °C to +105 °C)		-	-	24	
	Deep power down current (-40 °C to +125 °C)		-	-	35	
I _{HS} ^[34]	Hybrid sleep current (-40 °C to +85 °C)	CS# = V _{CC} , V _{CC} = V _{CC} max; full Array	-	280	2200	μA
		CS# = V _{CC} , V _{CC} = V _{CC} max; bottom 1/2 Array	-		1600	
		CS# = V _{CC} , V _{CC} = V _{CC} max; bottom 1/4 Array	-		1200	

Notes

33. Not 100% tested.

34. RESET# LOW initiates exits from DPD and hybrid sleep state and initiates the draw of I_{CC5} reset current, making I_{LI} during RESET# LOW insignificant.

Electrical specifications

Table 21 DC Characteristics (CMOS compatible) (Continued)

Parameter	Description	Test conditions	512 Mb			Unit			
			Min	Typ ^[33]	Max				
I_{HS} ^[34]	Hybrid sleep current (-40 °C to +85 °C)	CS# = V _{CC} , V _{CC} = V _{CC} max; bottom 1/8 Array	-	280	1000	μ A			
		CS# = V _{CC} , V _{CC} = V _{CC} max; top 1/2 Array	-		1600				
		CS# = V _{CC} , V _{CC} = V _{CC} max; top 1/4 Array	-		1200				
		CS# = V _{CC} , V _{CC} = V _{CC} max; top 1/8 Array	-		1000				
	Hybrid sleep current (-40 °C to +105 °C)	CS# = V _{CC} , V _{CC} = 2.0 V; full array	-		2500				
		CS# = V _{CC} , V _{CC} = 2.0 V; bottom 1/2 array	-		1700				
		CS# = V _{CC} , V _{CC} = 2.0 V; bottom 1/4 array	-		1300				
		CS# = V _{CC} , V _{CC} = 2.0 V; bottom 1/8 array	-		1100				
		CS# = V _{CC} , V _{CC} = 2.0 V; top 1/2 array	-		1700				
		CS# = V _{CC} , V _{CC} = 2.0 V; top 1/4 array	-		1300				
		CS# = V _{CC} , V _{CC} = 2.0 V; top 1/8 array	-		1100				
	Hybrid sleep current (-40 °C to +125 °C)	CS# = V _{CC} , V _{CC} = 2.0 V; full array	-		3000				
		CS# = V _{CC} , V _{CC} = 2.0 V; bottom 1/2 array	-		2300				
		CS# = V _{CC} , V _{CC} = 2.0 V; bottom 1/4 array	-		1800				
		CS# = V _{CC} , V _{CC} = 2.0 V; bottom 1/8 array	-		1500				
		CS# = V _{CC} , V _{CC} = 2.0 V; top 1/2 array	-		2300				
		CS# = V _{CC} , V _{CC} = 2.0 V; top 1/4 array	-		1800				
		CS# = V _{CC} , V _{CC} = 2.0 V; top 1/8 array	-		1500				
	V _{IL}	Input low voltage	-		-0.15 × V _{CCQ}		-	0.30 × V _{CCQ}	V
	V _{IH}	Input high voltage	-		0.70 × V _{CCQ}		-	1.15 × V _{CCQ}	
	V _{OL}	Output low voltage	I _{OL} = 100 μ A for DQ[7:0]		-		-	0.20	
V _{OH}	Output high voltage	I _{OH} = 100 μ A for DQ[7:0]	V _{CCQ} - 0.20	-	-				

Notes

33. Not 100% tested.

34. RESET# LOW initiates exits from DPD and hybrid sleep state and initiates the draw of I_{CC5} reset current, making I_{L1} during RESET# LOW insignificant.

9.5.1 Capacitance Characteristics

Table 22 Capacitive characteristics^[35-37]

Description	Parameter	512 Mb	Unit
		Max	
Input capacitance (CK, CK#, CS#)	CI	6	pF
Delta input capacitance (CK, CK#)	CID	0.50	
Output capacitance (RWDS)	CO	6	
IO capacitance (DQx)	CIO	6	
IO capacitance delta (DQx)	CIOD	0.50	

Table 23 Thermal resistance

Parameter ^[38]	Description	Test conditions	24-ball FBGA package	Unit
θ_{JA}	Thermal resistance (junction to ambient)	Test conditions follow standard test methods and procedures for measuring thermal impedance, per EIA/JESD51.	51	°C/W
θ_{JC}	Thermal resistance (junction to case)		8	

Notes

35. These values are guaranteed by design and are tested on a sample basis only.
36. Contact capacitance is measured according to JEP147 procedure for measuring capacitance using a vector network analyzer. V_{CC} , V_{CCQ} are applied and all other signals (except the signal under test) floating. DQ's should be in the high impedance state.
37. Note that the capacitance values for the CK, CK#, RWDS and DQx signals must have similar capacitance values to allow for signal propagation time matching in the system. The capacitance value for CS# is not as critical because there are no critical timings between CS# going active (LOW) and data being presented on the DQs bus.
38. This parameter is guaranteed by characterization; not tested in production.

9.6 Power-up initialization

HYPERRAM™ products include an on-chip voltage sensor used to launch the power-up initialization process. V_{CC} and V_{CCQ} must be applied simultaneously. When the power supply reaches a stable level at or above $V_{CC}(\text{min})$, the device will require t_{VCS} time to complete its self-initialization process.

The device must not be selected during power-up. CS# must follow the voltage applied on V_{CCQ} until $V_{CC}(\text{min})$ is reached during power-up, and then CS# must remain high for a further delay of t_{VCS} . A simple pull-up resistor from V_{CCQ} to Chip Select (CS#) can be used to insure safe and proper power-up.

If RESET# is LOW during power up, the device delays start of the t_{VCS} period until RESET# is HIGH. The t_{VCS} period is used primarily to perform refresh operations on the DRAM array to initialize it.

When initialization is complete, the device is ready for normal operation.

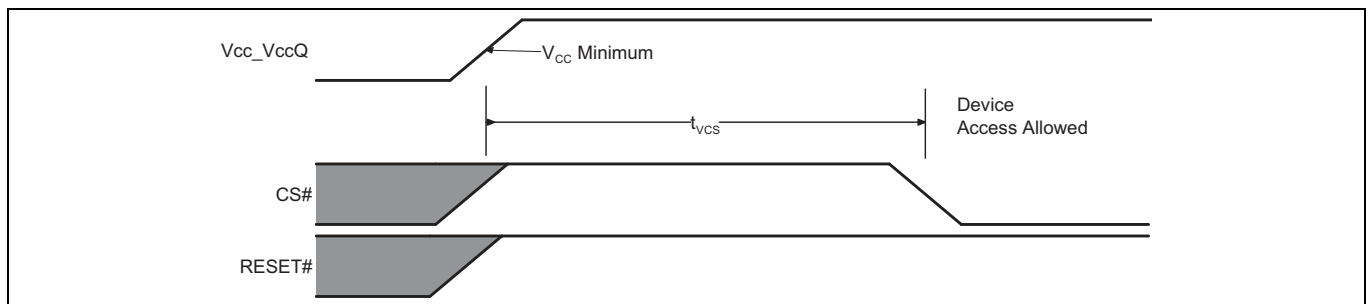

Figure 23 Power-up with RESET# HIGH

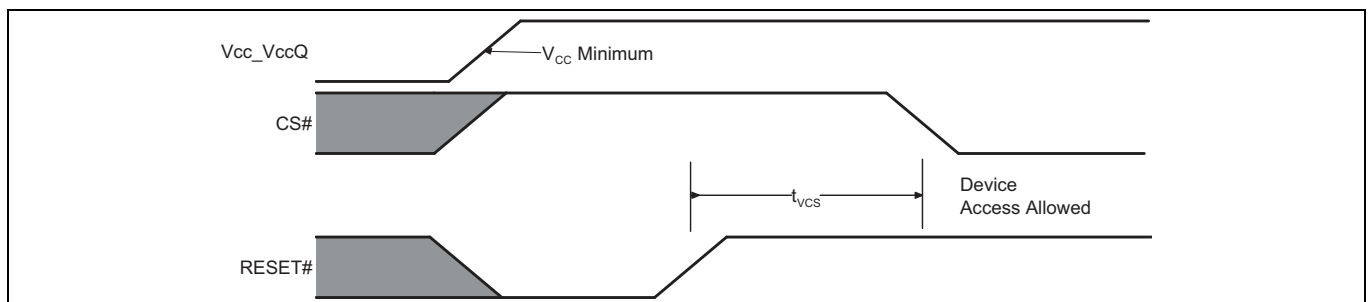

Figure 24 Power-up with RESET# LOW

Table 24 Power-up and reset parameters^[39-41]

Parameter	Description	Min	Max	Unit
V_{CC}	V_{CC} power supply	1.7	2.0	V
t_{VCS}	V_{CC} and $V_{CCQ} \geq$ minimum and RESET# HIGH to first access	-	150	μs

Notes

39. Bus transactions (read and write) are not allowed during the power-up reset time (t_{VCS}).
40. V_{CCQ} must be the same voltage as V_{CC} .
41. V_{CC} ramp rate may be non-linear.

9.7 Power down

HYPERRAM™ devices are considered to be powered-off when the array power supply (V_{CC}) drops below the V_{CC} Lock-Out voltage (V_{LKO}). During a power supply transition down to the V_{SS} level, V_{CCQ} should remain less than or equal to V_{CC} . At the V_{LKO} level, the HYPERRAM™ device will have lost configuration or array data.

V_{CC} must always be greater than or equal to V_{CCQ} ($V_{CC} \geq V_{CCQ}$).

During power-down or voltage drops below V_{LKO} , the array power supply voltages must also drop below V_{CC} Reset (V_{RST}) for a Power Down period (t_{PD}) for the part to initialize correctly when the power supply again rises to V_{CC} minimum. See [Figure 25](#).

If during a voltage drop the V_{CC} stays above V_{LKO} the part will stay initialized and will work correctly when V_{CC} is again above V_{CC} minimum. If V_{CC} does not go below and remain below V_{RST} for greater than t_{PD} , then there is no assurance that the POR process will be performed. In this case, a hardware reset will be required ensure the device is properly initialized.

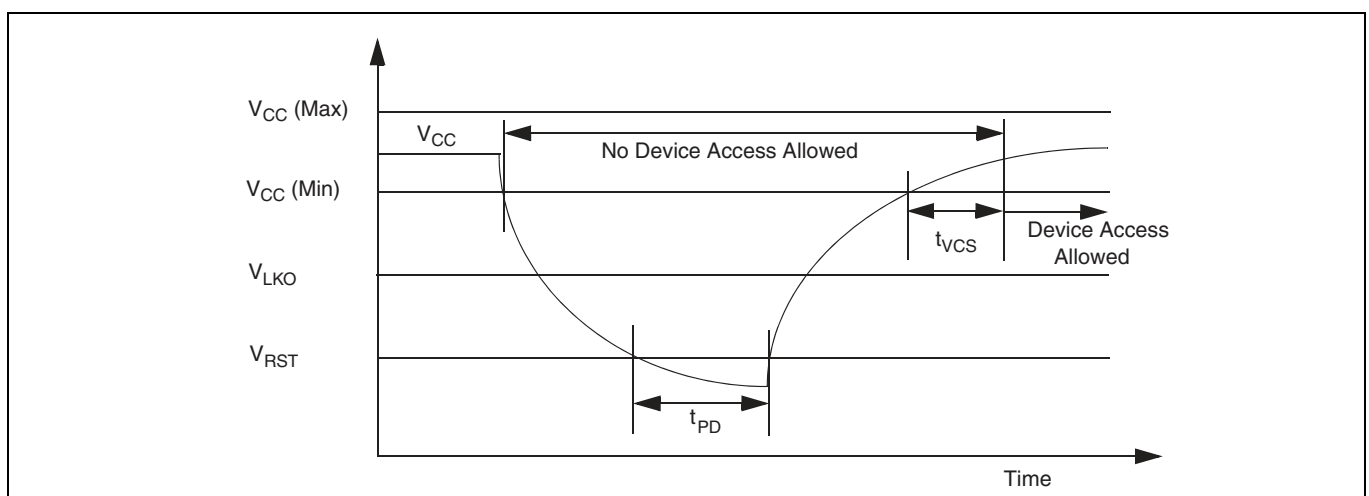

Figure 25 Power down or voltage drop

The following section describes HYPERRAM™ device dependent aspects of power down specifications.

Table 25 Power-down voltage and timing^[42]

Symbol	Parameter	Min	Max	Unit
V_{CC}	V_{CC} power supply	1.7	2.0	V
V_{LKO}	V_{CC} lock-out below which re-initialization is required	1.5	–	V
V_{RST}	V_{CC} low Voltage needed to ensure initialization will occur	0.7	–	V
t_{PD}	Duration of $V_{CC} \leq V_{RST}$	50	–	μ s

Note

42. V_{CC} ramp rate can be non-linear.

9.8 Hardware reset

The RESET# input provides a hardware method of returning the device to the standby state.

During t_{RPH} the device will draw I_{CC5} current. If RESET# continues to be held LOW beyond t_{RPH} , the device draws CMOS standby current (I_{CC4}). While RESET# is LOW (during t_{RP}), and during t_{RPH} , bus transactions are not allowed.

A hardware reset will do the following:

- Cause the configuration registers to return to their default values
- Halt self-refresh operation while RESET# is LOW - memory array data is considered as invalid
- Force the device to exit the Hybrid Sleep state
- Force the device to exit the Deep Power Down state

After RESET# returns HIGH, the self-refresh operation will resume. Because self-refresh operation is stopped during RESET# LOW, and the self-refresh row counter is reset to its default value, some rows may not be refreshed within the required array refresh interval per [Table 14](#). This may result in the loss of DRAM array data during or immediately following a hardware reset. The host system should assume DRAM array data is lost after a hardware reset and reload any required data.

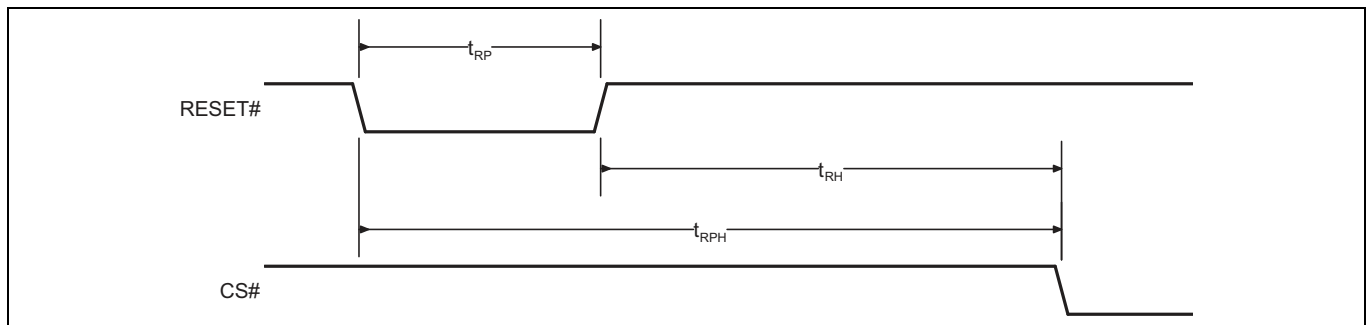

Figure 26 Hardware reset timing diagram

Table 26 Power-up and reset parameters

Parameter	Description	Min	Max	Unit
t_{RP}	RESET# pulse width	200	–	ns
t_{RH}	Time between RESET# (HIGH) and CS# (LOW)	200	–	
t_{RPH}	RESET# LOW to CS# LOW	400	–	

10 Timing specifications

The following section describes HYPERRAM™ device dependent aspects of timing specifications.

10.1 Key to switching waveforms

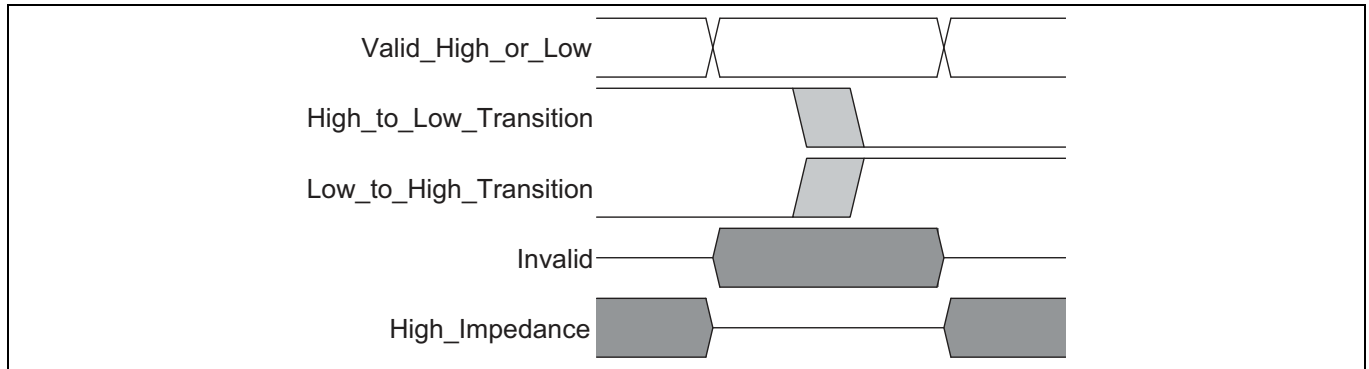

Figure 27 Key to switching waveforms

10.2 AC test conditions

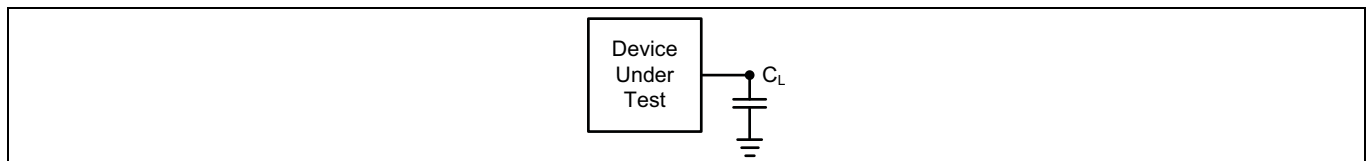

Figure 28 Test setup

Table 27 Test specification^[43]

Parameter	All speeds	Units
Output load capacitance, C_L	15	pF
Minimum input rise and fall slew rates (1.8 V) ^[44]	1.13	V/ns
Input pulse levels	0.0– V_{CCQ}	V
Input timing measurement reference levels	$V_{CCQ}/2$	V
Output timing measurement reference levels	$V_{CCQ}/2$	V

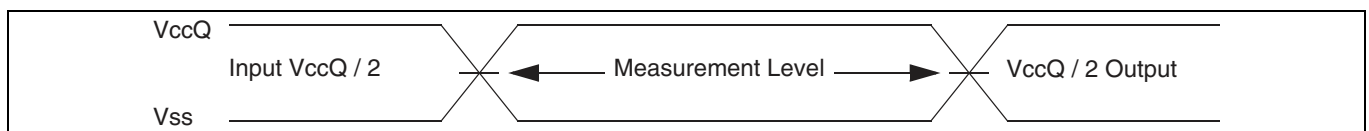

Figure 29 Input waveforms and measurement levels^[45]

Notes

43. Input and output timing is referenced to $V_{CCQ}/2$ or to the crossing of CK/CK#.
44. All AC timings assume this input slew rate.
45. Input timings for the differential CK/CK# pair are measured from clock crossings.

10.3 CLK characteristics

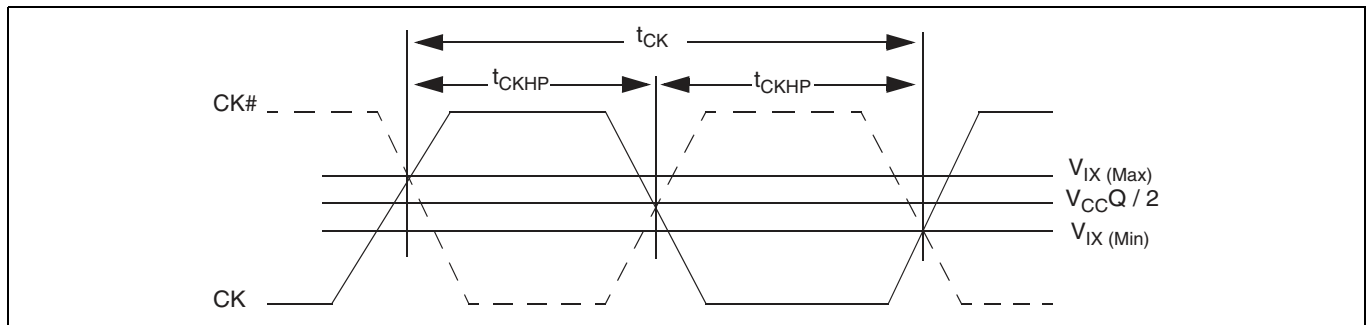

Figure 30 Clock characteristics^[46]

Table 28 Clock Timings^[47-49]

Parameter	Symbol	200 MHz		Unit
		Min	Max	
CK period	t_{CK}	5	–	ns
CK half period - duty cycle	t_{CKHP}	0.45	0.55	t_{CK}
CK half period at frequency Min = 0.45 t_{CK} Min Max = 0.55 t_{CK} Min	t_{CKHP}	2.25	2.75	ns

Table 29 Clock AC/DC electrical characteristics^[50, 51]

Parameter	Symbol	Min	Max	Unit
DC input voltage	V_{IN}	-0.3	$V_{CCQ} + 0.3$	V
DC input differential voltage	$V_{ID(DC)}$	$V_{CCQ} \times 0.4$	$V_{CCQ} + 0.6$	
AC input differential voltage	$V_{ID(AC)}$	$V_{CCQ} \times 0.6$	$V_{CCQ} + 0.6$	
AC differential crossing voltage	V_{IX}	$V_{CCQ} \times 0.4$	$V_{CCQ} \times 0.6$	

Notes

- 46. CK# is shown as a dashed waveform.
- 47. Clock jitter of $\pm 5\%$ is permitted
- 48. Minimum frequency (maximum t_{CK}) is dependent upon maximum CS# Low time (t_{CSM}), Initial Latency, and Burst Length.
- 49. CK and CK# input slew rate must be ≥ 1 V/ns (2 V/ns if measured differentially).
- 50. V_{ID} is the magnitude of the difference between the input level on CK and the input level on CK#.
- 51. The value of V_{IX} is expected to equal $V_{CCQ}/2$ of the transmitting device and must track variations in the DC level of V_{CCQ} .

Timing specifications

10.4 AC characteristics

10.4.1 Read transactions

Table 30 HYPERRAM™ specific read timing parameters

Parameter	Symbol	200 MHz		Unit
		Min	Max	
Chip select high between transactions	t_{CSHI}	6	–	ns
HYPERRAM™ read-write recovery time	t_{RWR}	35	–	
Chip select setup to next CK rising edge	t_{CSS}	4	–	
Data strobe valid	t_{DSV}	–	5	
Input setup	t_{IS}	0.5	–	
Input hold	t_{IH}	0.5	–	
HYPERRAM™ read initial access time	t_{ACC}	35	–	
Clock to DQs low Z	t_{DQLZ}	0	–	
CK transition to DQ valid	t_{CKD}	1	5	
CK transition to DQ invalid	t_{CKDI}	0	4.2	
Data valid (t_{DV} min = the lesser of: t_{CKHP} min – t_{CKD} max + t_{CKDI} max) or t_{CKHP} min – t_{CKD} min + t_{CKDI} min)	$t_{DV}^{[52, 53]}$	1.45	–	
CK transition to RWDS valid	t_{CKDS}	1	5	
RWDS transition to DQ valid	t_{DSS}	–0.4	+0.4	
RWDS transition to DQ invalid	t_{DSH}	–0.4	+0.4	
Chip select hold after CK falling edge	t_{CSH}	0	–	
Chip select inactive to RWDS high-Z	t_{DSZ}	–	5	
Chip select inactive to DQ High-Z	t_{OZ}	–	5	
Refresh time	t_{RFH}	35	–	
CK transition to RWDS Low @ CA phase @ read	t_{CKDSR}	1	5.5	

Notes

52. Refer to [Figure 32](#) for data valid timing.

53. The t_{DV} timing calculation is provided for reference only, not to determine the spec limit. The spec limit is guaranteed by testing.

Timing specifications

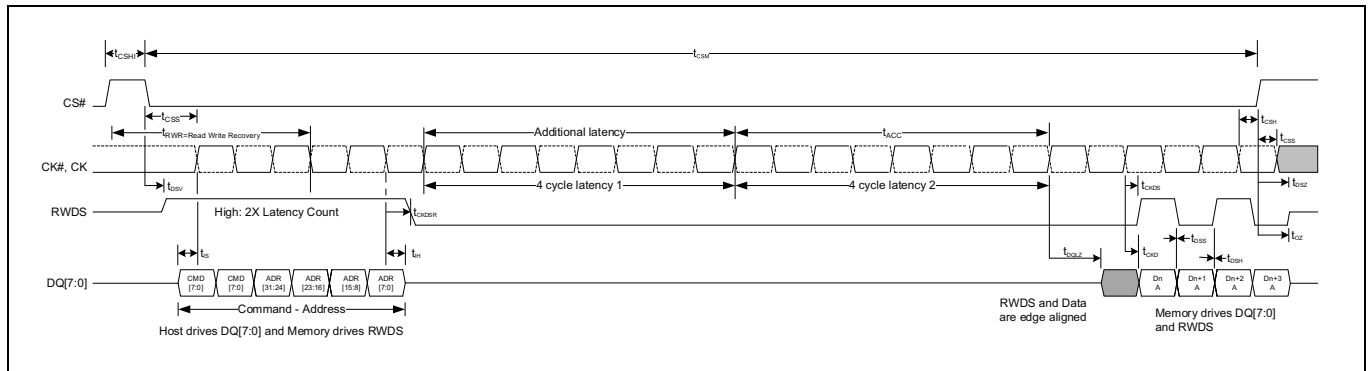

Figure 31 Read timing diagram^[54]

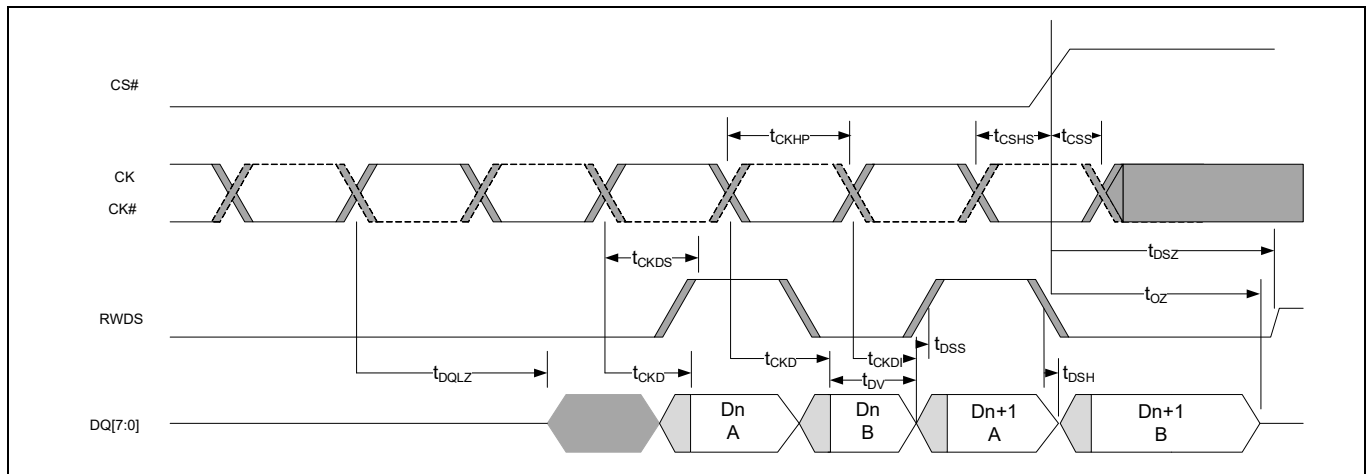

Figure 32 Data valid timing^[55-57]

- Notes**
- 54. Refer to **Figure 32** for data valid timing.
 - 55. t_{CKD} and t_{CKD}^* parameters define the beginning and end position of data valid period.
 - 56. t_{DSS} and t_{DSH} define how early or late DQ may transition relative to RWDS. This is a potential skew between the CK to DQ delay t_{CKD} and CK to RWDS delay t_{CKDS} .
 - 57. Since DQ and RWDS are the same output types, the t_{CKD} , t_{CKD}^* and t_{CKDS} values track together (vary by the same ratio).

Timing specifications

10.4.2 Write transactions

Table 31 Write timing parameters

Parameter	Symbol	200 MHz		Unit
		Min	Max	
Read-write recovery time	t_{RWR}	35	–	ns
Access time	t_{ACC}	35	–	
Refresh time	t_{RFH}	35	–	
Chip select maximum low time (85 °C)	t_{CSM}	–	4	μ s
Chip select maximum low time (105 °C)	t_{CSM}	–	1	
RWDS data mask valid	t_{DMV}	0	–	

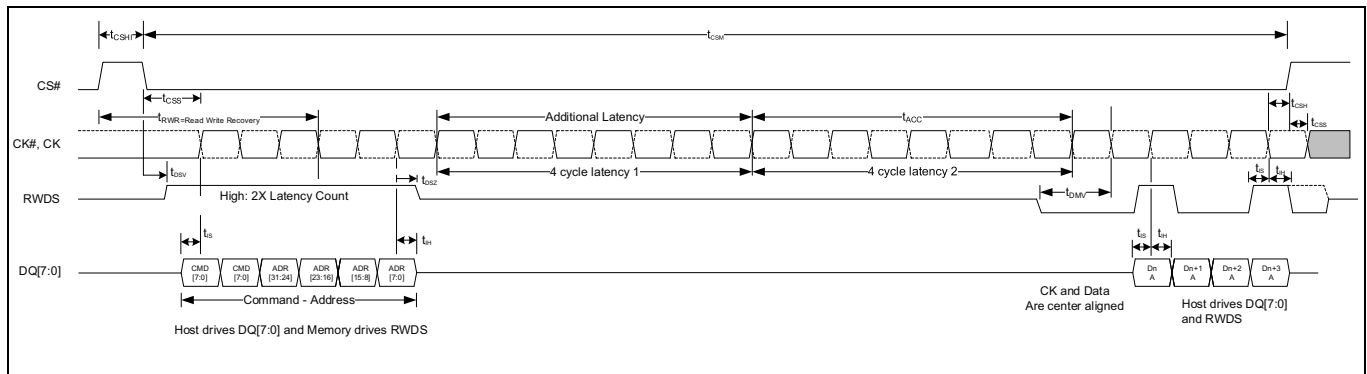

Figure 33 Write timing diagram^[58]

Note

58. The initial latency “Low = 1x latency count” is not applicable in dual-die, 512-Mb HYPERRAM™.

10.5 Timing reference levels

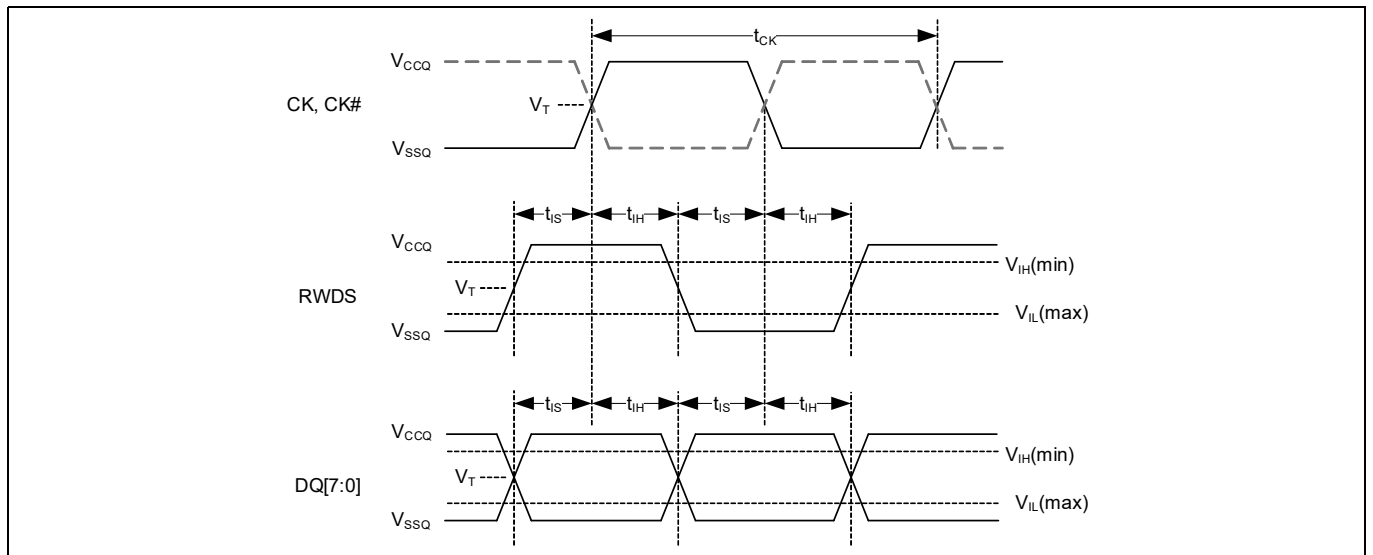

Figure 34 DDR input timing reference levels

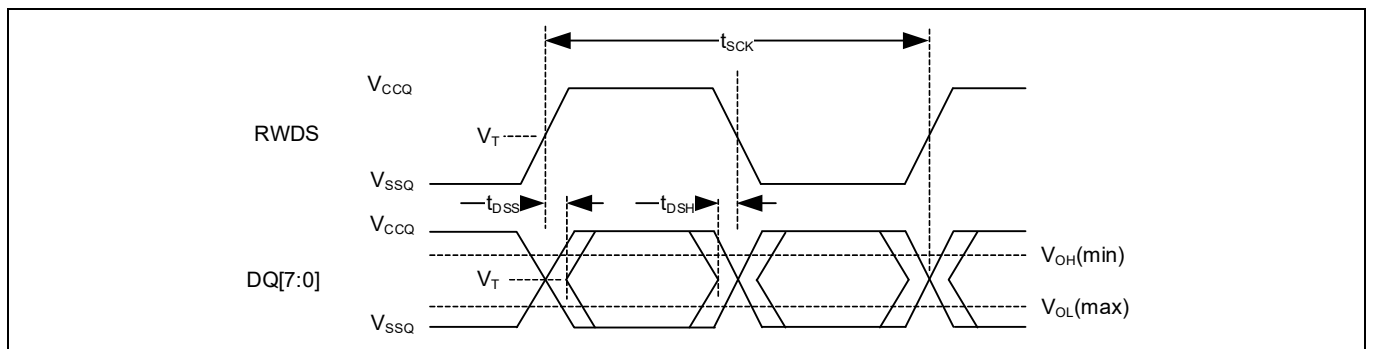

Figure 35 DDR output timing reference levels

Physical interface

11 Physical interface

11.1 FBGA 24-ball 5 x 5 array footprint

HYPERRAM™ devices are provided in Fortified Ball Grid Array (FBGA), 1 mm pitch, 24-ball, 5 x 5 ball array footprint, with 6 mm × 8 mm body.

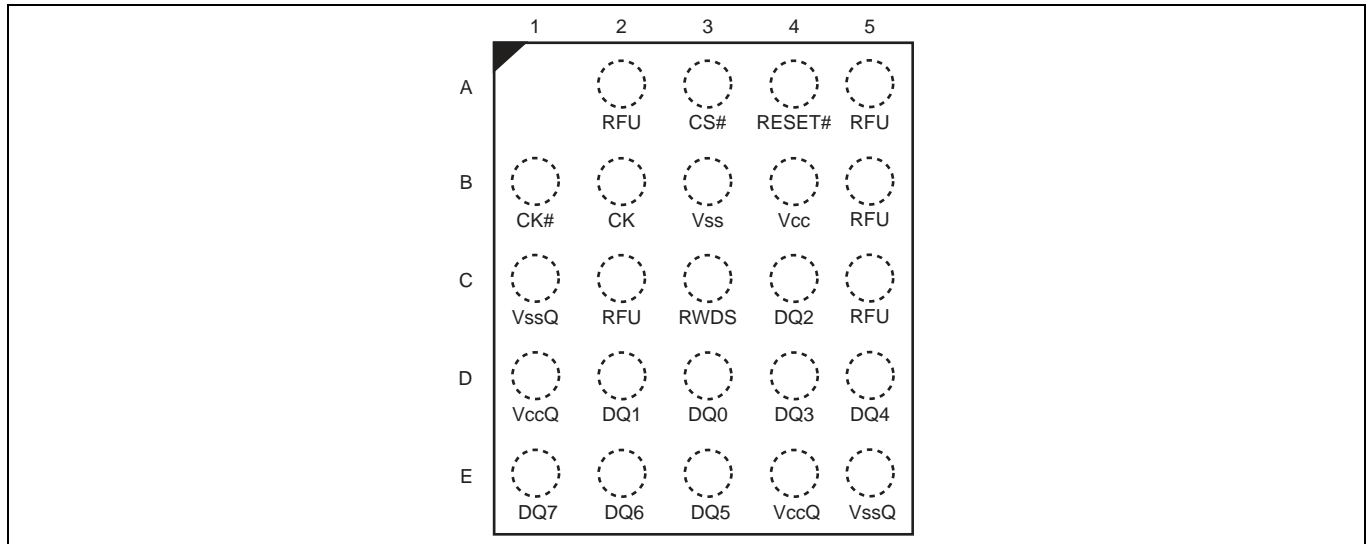
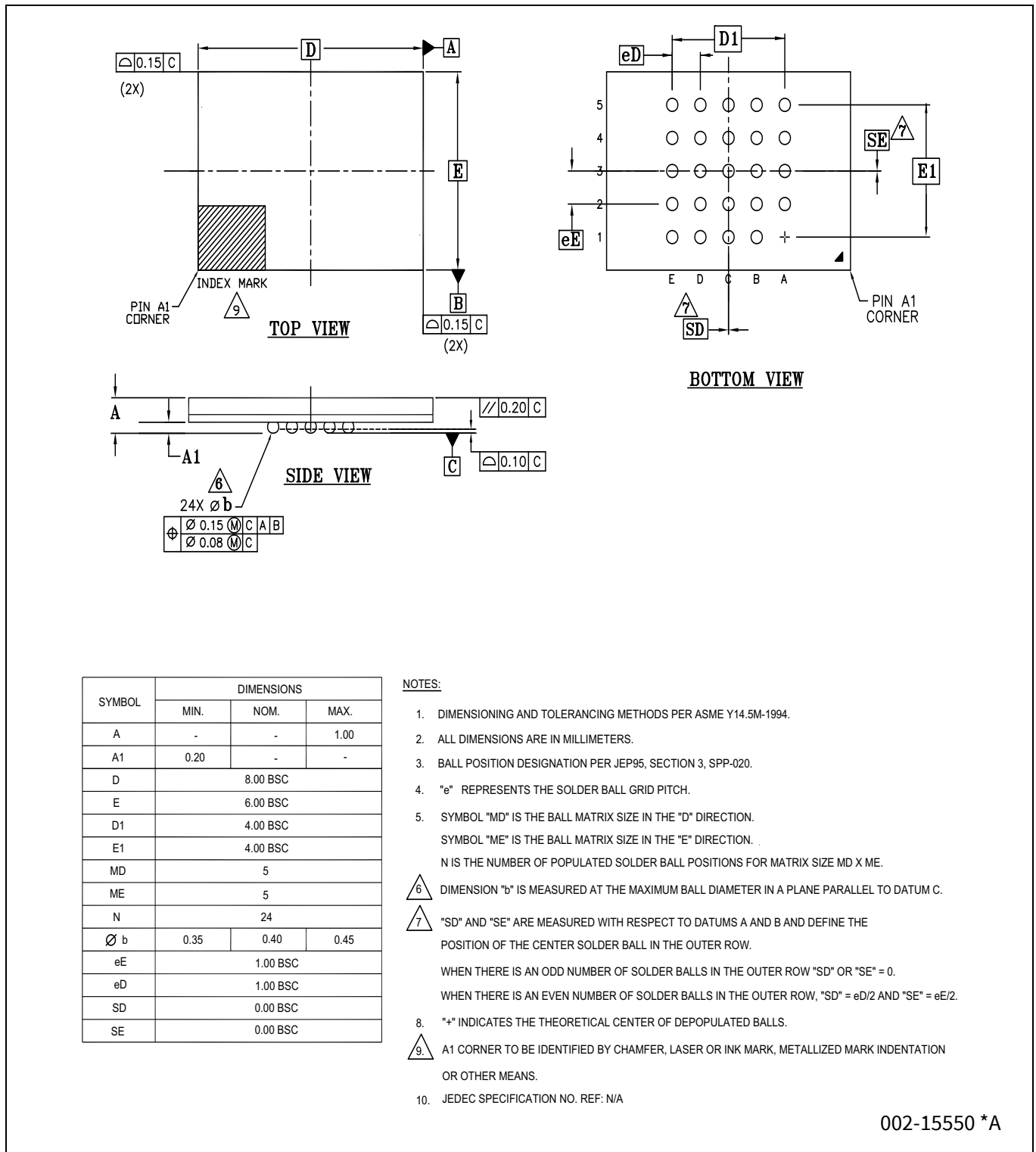

Figure 36 24-ball FBGA, 6 x 8 mm, 5 x 5 ball footprint, top view

11.2 Physical diagram



002-15550 *A

Figure 37 24-ball BGA (8.0 mm x 6.0 mm x 1.0 mm) package outline

12 Ordering information

12.1 Ordering part number

The ordering part number is formed by a valid combination of the following:

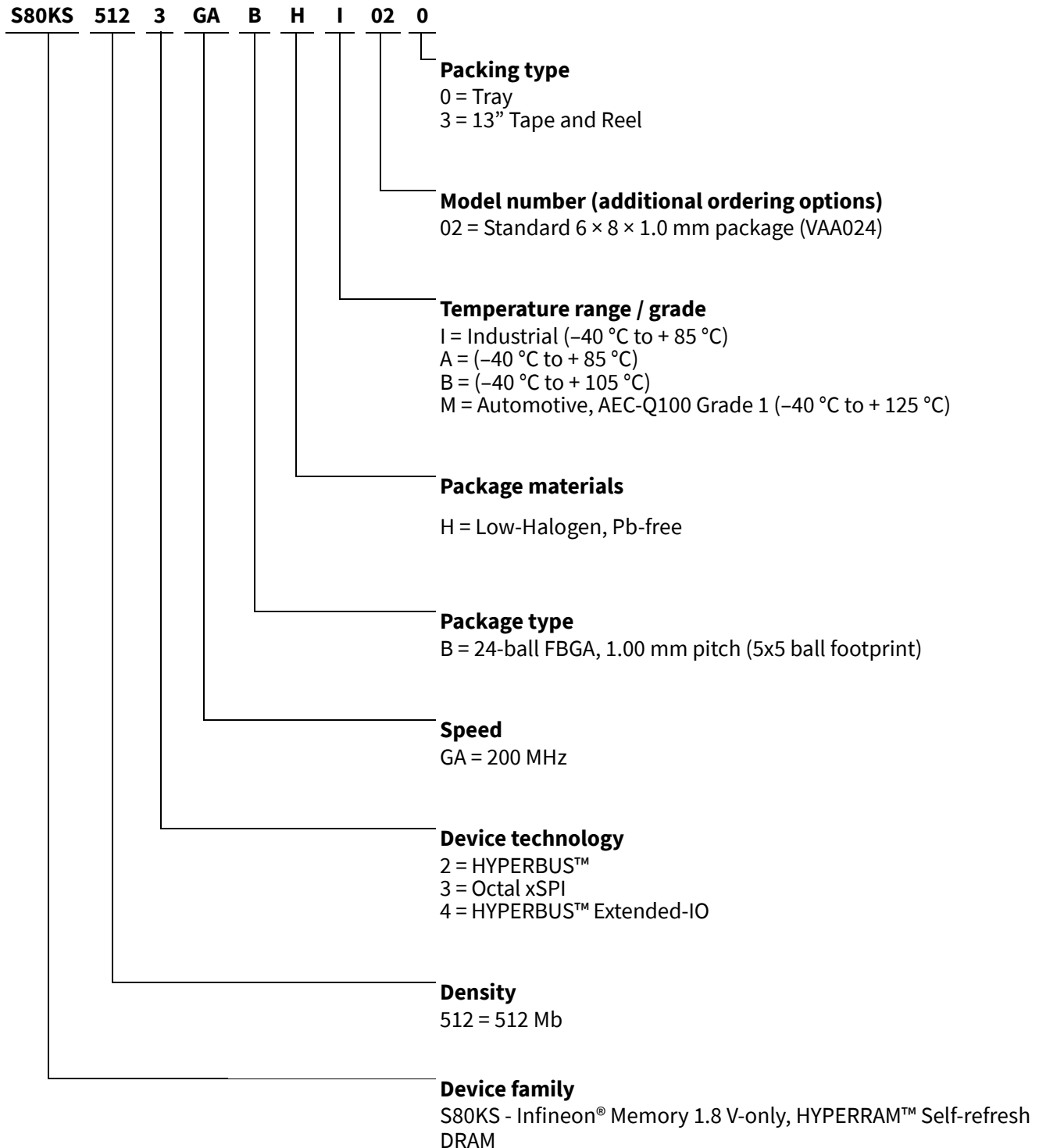

12.2 Valid combinations

The Recommended Combinations table lists configurations planned to be available in volume. **Table 32** will be updated as new combinations are released. Contact your local sales representative to confirm availability of specific combinations and to check on newly released combinations.

Table 32 Valid combinations - standard

Device family	Density	Technology	Speed	Package, material, and temperature	Model number	Packing type	Ordering part number	Package marking
S80KS	512	3	GA	BHI	02	0	S80KS5123GABHI020	8KS5123GAHI02
S80KS	512	3	GA	BHI	02	3	S80KS5123GABHI023	8KS5123GAHI02
S80KS	512	3	GA	BHV	02	0	S80KS5123GABHV020	8KS5123GAHV02
S80KS	512	3	GA	BHV	02	3	S80KS5123GABHV023	8KS5123GAHV02

12.3 Valid combinations - Automotive grade / AEC-Q100

Table 33 list configurations that are Automotive Grade / AEC-Q100 qualified and are planned to be available in volume. The table will be updated as new combinations are released. Contact your local sales representative to confirm availability of specific combinations and to check on newly released combinations.

Production part approval process (PPAP) support is only provided for AEC-Q100 grade products.

Products to be used in end-use applications that require ISO/TS-16949 compliance must be AEC-Q100 grade products in combination with PPAP. Non-AEC-Q100 grade products are not manufactured or documented in full compliance with ISO/TS-16949 requirements.

AEC-Q100 grade products are also offered without PPAP support for end-use applications that do not require ISO/TS-16949 compliance.

Table 33 Valid combinations - Automotive grade / AEC-Q100

Device family	Density	Technology	Speed	Package, material, and temperature	Model number	Packing type	Ordering part number	Package marking
S80KS	512	3	GA	BHA	02	0	S80KS5123GABHA020	8KS5123GAHA02
S80KS	512	3	GA	BHA	02	3	S80KS5123GABHA023	8KS5123GAHA02
S80KS	512	3	GA	BHB	02	0	S80KS5123GABHB020	8KS5123GAHB02
S80KS	512	3	GA	BHB	02	3	S80KS5123GABHB023	8KS5123GAHB02
S80KS	512	3	GA	BHM	02	0	S80KS5123GABHM020	8KS5123GAHM02
S80KS	512	3	GA	BHM	02	3	S80KS5123GABHM023	8KS5123GAHM02

13 Acronyms

Table 34 Acronyms used in this document

Acronym	Description
CMOS	complementary metal oxide semiconductor
DCARS	DDR Center-Aligned Read Strobe
DDR	double data rate
DPD	deep power down
DRAM	dynamic RAM
HS	hybrid sleep
MSb	most significant bit
POR	power-on reset
PSRAM	pseudo static RAM
PVT	process, voltage, and temperature
RWDS	read-write data strobe
SPI	serial peripheral interface
xSPI	expanded serial peripheral interface

14 Document conventions

14.1 Units of measure

Table 35 Units of measure

Symbol	Unit of Measure
°C	degree Celsius
MHz	megahertz
μA	microampere
μs	microsecond
mA	milliampere
mm	millimeter
ns	nanosecond
Ω	ohm
%	percent
pF	picofarad
V	volt
W	watt

Revision history

Revision history

Document version	Date of release	Description of changes
*C	2021-09-27	Publish to web.

Trademarks

All referenced product or service names and trademarks are the property of their respective owners.

Edition 2021-09-27
Published by
Infineon Technologies AG
81726 Munich, Germany

© 2021 Infineon Technologies AG.
All Rights Reserved.

Do you have a question about this document?
Go to www.cypress.com/support

Document reference
002-31340 Rev. *C

IMPORTANT NOTICE

The information given in this document shall in no event be regarded as a guarantee of conditions or characteristics ("Beschaffenhheitsgarantie").

With respect to any examples, hints or any typical values stated herein and/or any information regarding the application of the product, Infineon Technologies hereby disclaims any and all warranties and liabilities of any kind, including without limitation warranties of non-infringement of intellectual property rights of any third party.

In addition, any information given in this document is subject to customer's compliance with its obligations stated in this document and any applicable legal requirements, norms and standards concerning customer's products and any use of the product of Infineon Technologies in customer's applications.

The data contained in this document is exclusively intended for technically trained staff. It is the responsibility of customer's technical departments to evaluate the suitability of the product for the intended application and the completeness of the product information given in this document with respect to such application.

For further information on the product, technology, delivery terms and conditions and prices please contact your nearest Infineon Technologies office (www.infineon.com).

WARNINGS

Due to technical requirements products may contain dangerous substances. For information on the types in question please contact your nearest Infineon Technologies office.

Except as otherwise explicitly approved by Infineon Technologies in a written document signed by authorized representatives of Infineon Technologies, Infineon Technologies' products may not be used in any applications where a failure of the product or any consequences of the use thereof can reasonably be expected to result in personal injury.