

THIS DRAWING IS UNPUBLISHED. RELEASED FOR PUBLICATION
 © COPYRIGHT BY TYCO ELECTRONICS CORPORATION. ALL RIGHTS RESERVED.

LOC		DIST		REVISIONS					
P	LTR	DATE	DWN	APVD	DESCRIPTION				
DF	DO				J	UPDATE PER 0H2Y-0164-04	05-12-04	JDM	MKS

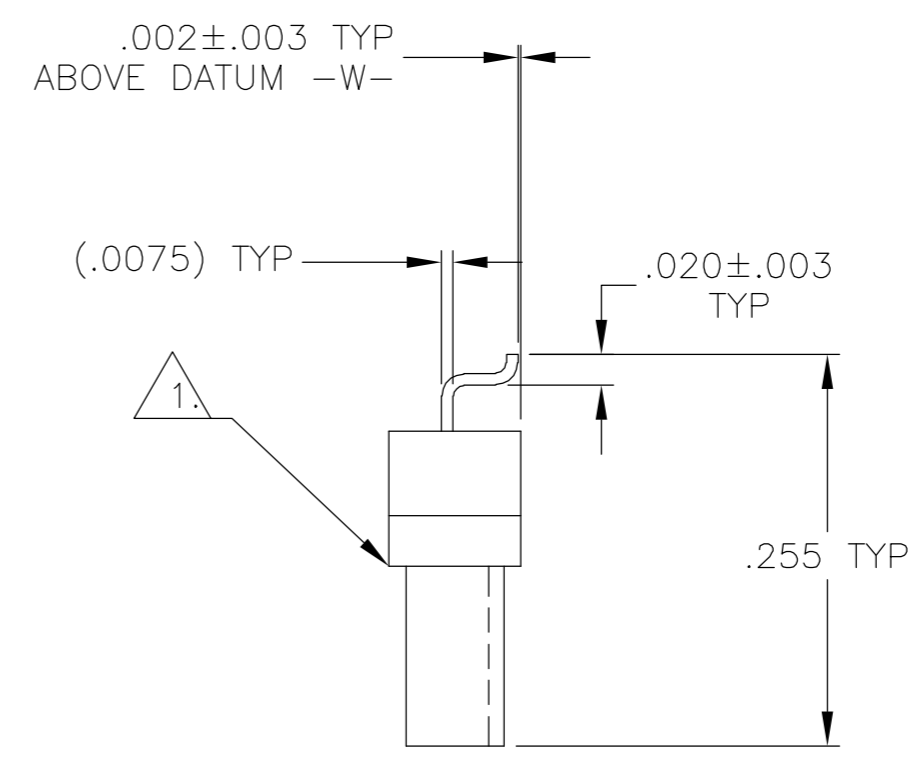
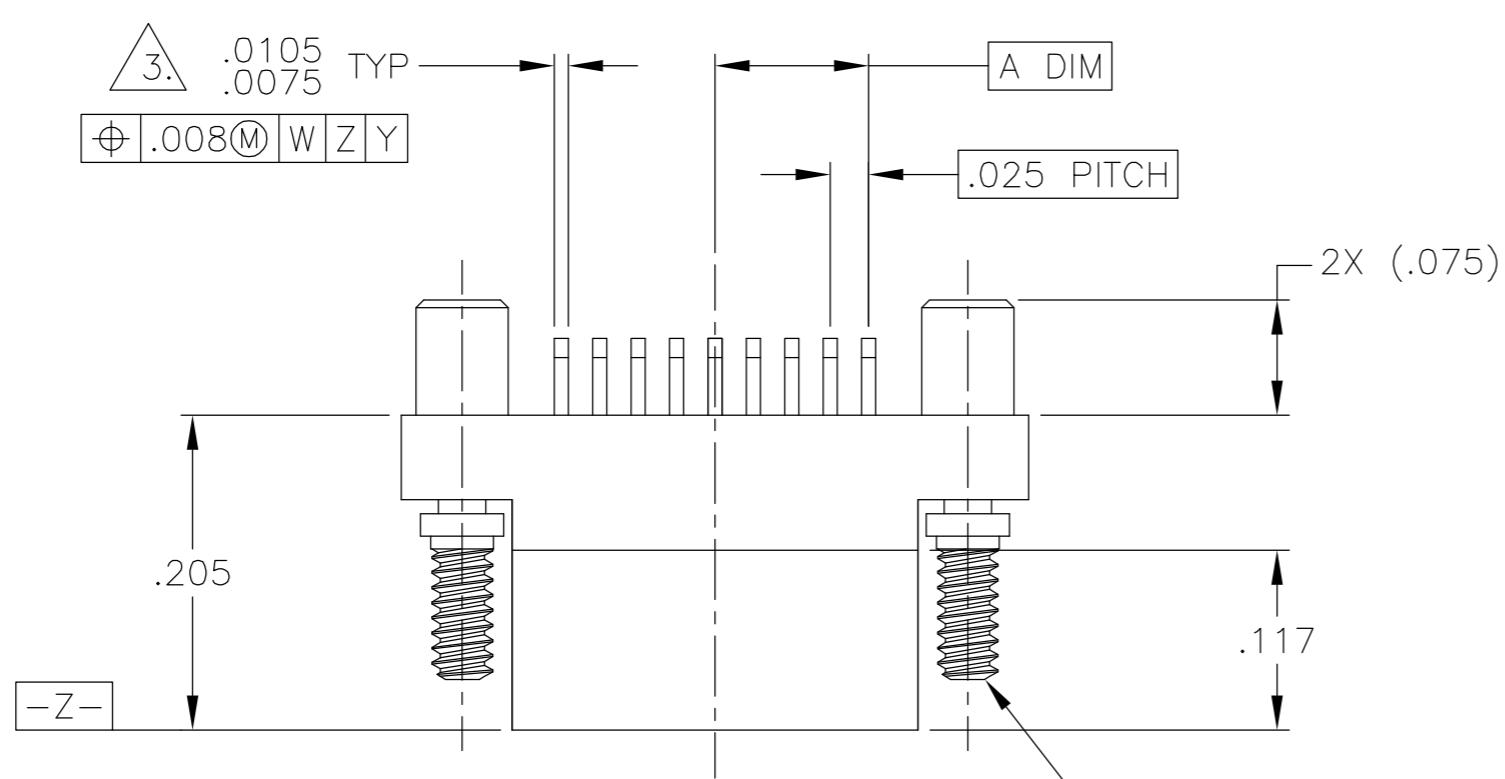

2X 1.00UNM (0.25mm PITCH) CAPTIVE JACKSCREW

JACKSCREW HEADS REMOVED FOR CLARITY

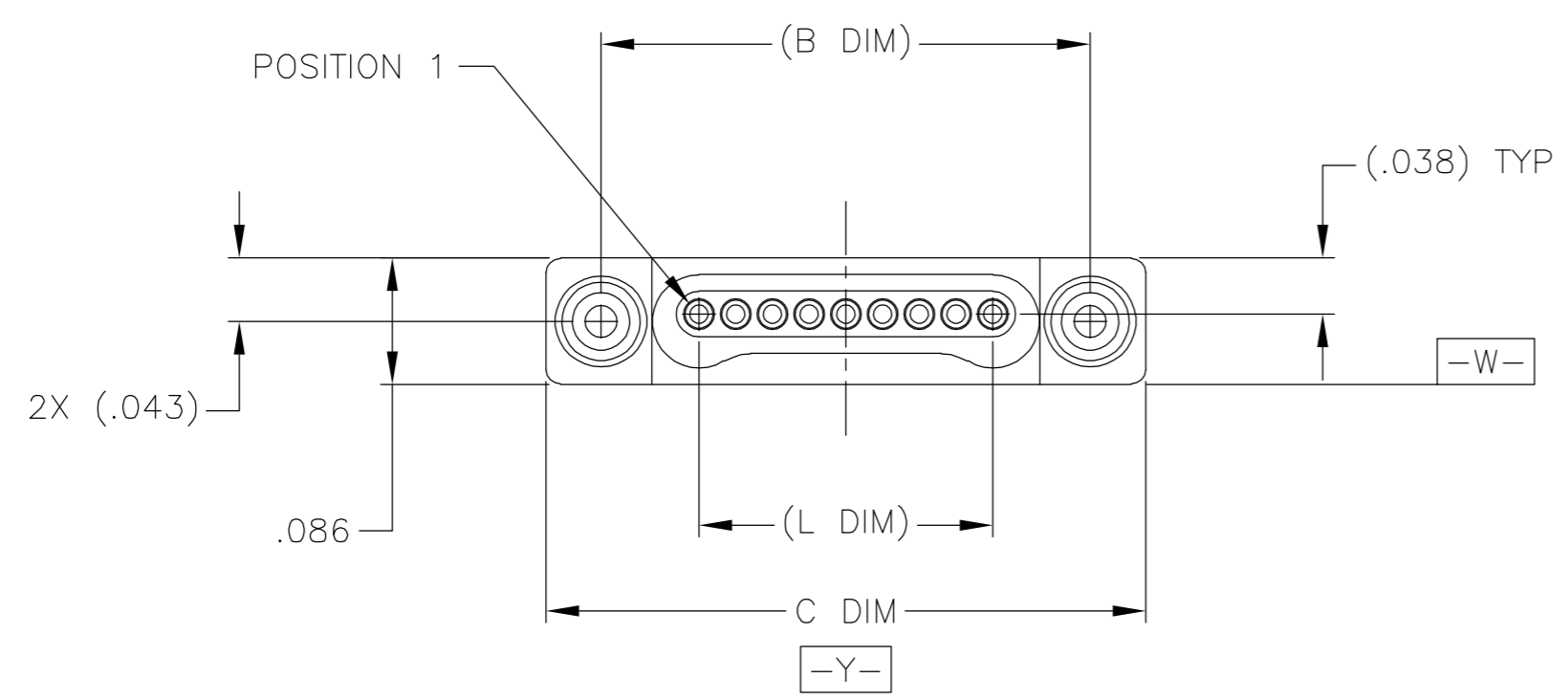

SIZE	A DIM	(B DIM)	C DIM ±.0050	(L DIM)
05	.050	(.233)	.3085	(.100)
09	.100	(.333)	.4085	(.200)
15	.175	(.483)	.5585	(.350)
25	.300	(.733)	.8085	(.600)
37	.450	(1.033)	1.1085	(.900)
51	.625	(1.383)	1.4585	(1.250)

1. SHELL OPTIONS (TO BE SPECIFIED IN NANONICS PART NUMBER):
 METAL: 6061-T6 ALUMINUM, ELECTROLESS NICKEL PLATED PER MIL-C-26074 (STANDARD) OR GOLD PLATED PER MIL-G-45204
 303 STAINLESS STEEL, PASSIVATED PER SAE-AMS-QQ-P-35
 INSULATOR MATERIAL FOR ALL METAL SHELLS IS LIQUID CRYSTAL POLYMER (LCP) PER MIL-M-24519 OR PER ASTM D5138
 PLASTIC: LIQUID CRYSTAL POLYMER (LCP) PER MIL-M-24519 OR PER ASTM D5138
2. STANDARD 1.00UNM CAPTIVE JACKSCREWS ARE SHOWN FOR REFERENCE ONLY AND MUST BE SPECIFIED IN THE NANONICS PART NUMBER WHEN REQUIRED. JACKSCREW MATERIAL IS 303 STAINLESS STEEL, PASSIVATED PER SAE-AMS-QQ-P-35, AND LUBED PER DOD-L-85645. RETAINING RING IS 17-4 STAINLESS STEEL, PASSIVATED PER SAE-AMS-QQ-P-35. JACKSCREWS HAVE A .9mm HEX SOCKET HEAD. 1.20UNM JACKSCREWS ALSO AVAILABLE.
3. SMT LEADS ARE BeCu, TIN LEAD PLATED 60/40 COMPOSITION PER SAE-AMS-P-81728
4. NANONICS TERMINATION CODE: B2
5. THIS DRAWING PREVIOUSLY IDENTIFIED AS NANONICS N10138/120

THIS DRAWING IS A CONTROLLED DOCUMENT.

DIMENSIONS: INCHES	TOLERANCES UNLESS OTHERWISE SPECIFIED:	DWN C. SCHOLL 04-19-01	Tyco Electronics Corporation Harrisburg, PA 17105																				
<table border="1"> <tr><td>0 PLC</td><td>±</td><td>-</td></tr> <tr><td>1 PLC</td><td>±</td><td>-</td></tr> <tr><td>2 PLC</td><td>±</td><td>.010</td></tr> <tr><td>3 PLC</td><td>±</td><td>.005</td></tr> <tr><td>4 PLC</td><td>±</td><td>-</td></tr> <tr><td>ANGLES</td><td>-</td><td>± 1°</td></tr> </table>	0 PLC	±		-	1 PLC	±	-	2 PLC	±	.010	3 PLC	±	.005	4 PLC	±	-	ANGLES	-	± 1°	<table border="1"> <tr><td>FINISH</td><td>SEE NOTES</td></tr> </table>	FINISH	SEE NOTES	CHK M. STORRY 04-20-01
0 PLC	±	-																					
1 PLC	±	-																					
2 PLC	±	.010																					
3 PLC	±	.005																					
4 PLC	±	-																					
ANGLES	-	± 1°																					
FINISH	SEE NOTES																						
MATERIAL SEE NOTES	FINISH SEE NOTES	APVD -	PRODUCT SPEC -																				
		APPLICATION SPEC -	PLUG ASSEMBLY, HORIZONTAL SURFACE MOUNT, SINGLE ROW DUALLOBE, PLASTIC OR METAL																				
		WEIGHT -	SIZE A2 CAGE CODE 00779 DRAWING NO. C=1589460 RESTRICTED TO -																				
		CUSTOMER DRAWING	SCALE 8:1 SHEET 1 OF 2 REV J																				

THIS DRAWING IS UNPUBLISHED. RELEASED FOR PUBLICATION
 © COPYRIGHT BY TYCO ELECTRONICS CORPORATION. ALL RIGHTS RESERVED.

LOC		DIST		REVISIONS			
P	LTR	DESCRIPTION		DATE	DWN	APVD	
	J	UPDATE PER 0H2Y-0164-04		05-12-04	JDM	MKS	

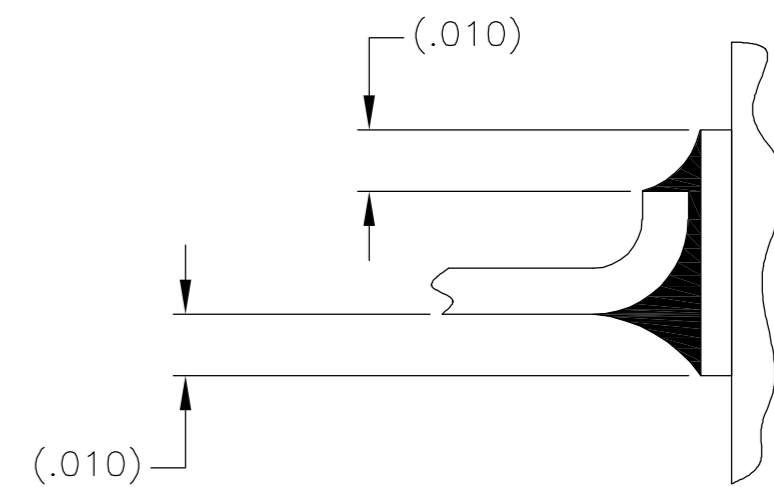
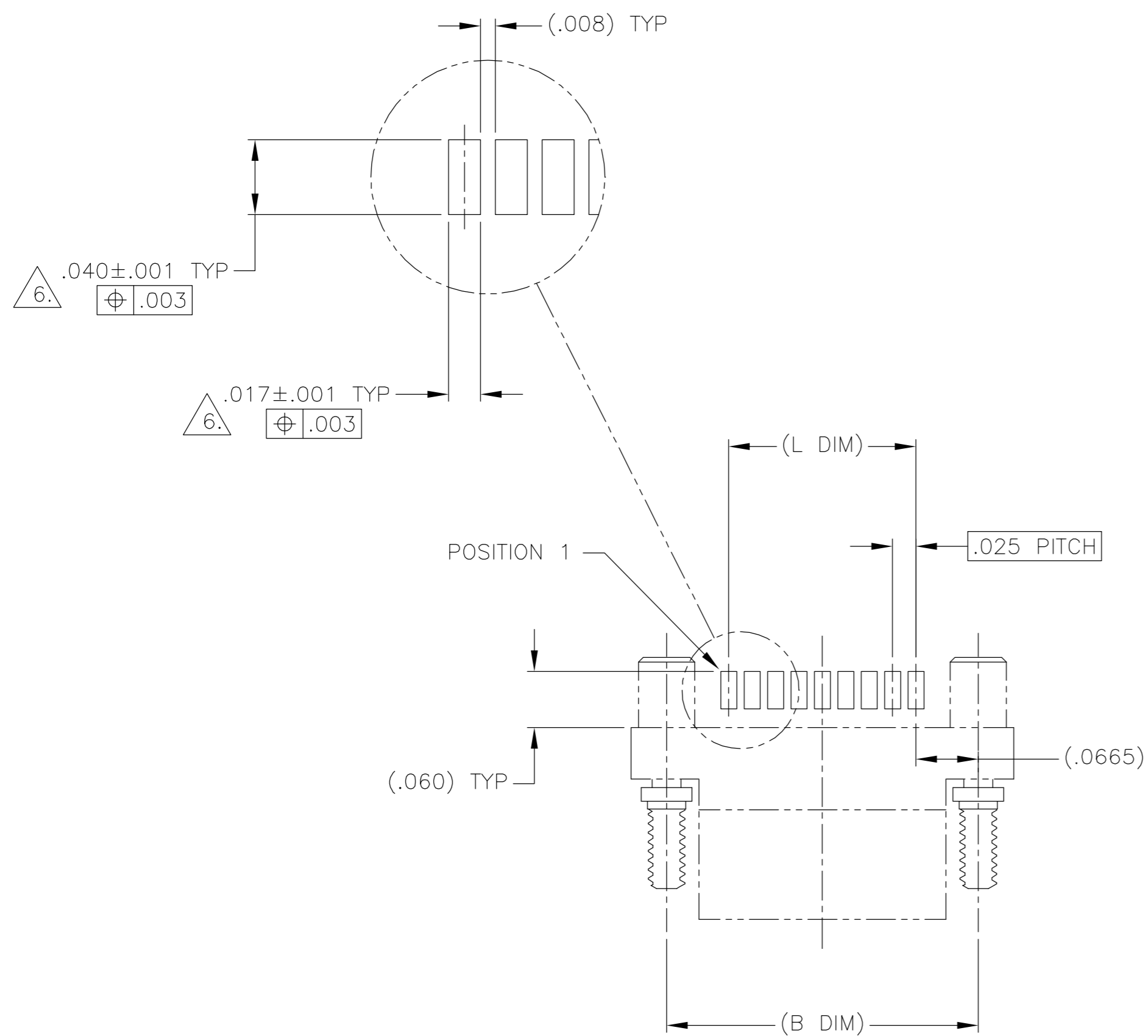

TYPICAL FOOT PLACEMENT
ON SOLDER PAD

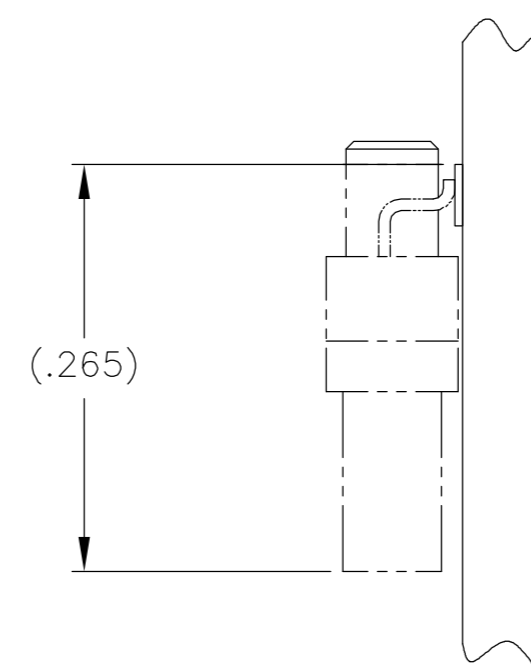

SIZE 09 SHOWN FOR REFERENCE

TYPICAL PCB LAYOUT

6. POSITIONAL TOLERANCES FOR BASIC DIMENSIONED FEATURES ARE RELATIVE TO FIDUCIALS OR SOME SIMILAR DATUM REFERENCE DEFINED BY THE PCB DESIGNER.

THIS DRAWING IS A CONTROLLED DOCUMENT.		DWN C. SCHOLL 04-19-01	Tyco Electronics Corporation Harrisburg, PA 17105	
DIMENSIONS: INCHES		CHK M. STORRY 04-20-01		
TOLERANCES UNLESS OTHERWISE SPECIFIED:		APVD -	NAME	
0 PLC ± - 1 PLC ± - 2 PLC ± .010 3 PLC ± .005 4 PLC ± - ANGLES ± 1°		PRODUCT SPEC -	PLUG ASSEMBLY, HORIZONTAL SURFACE MOUNT, SINGLE ROW DUALLOBE, PLASTIC OR METAL	
MATERIAL -		FINISH -	WEIGHT -	RESTRICTED TO -
		CUSTOMER DRAWING	SCALE 8:1	SHEET 2 OF 2
		SIZE A2	CAGE CODE 00779	DRAWING NO. C=1589460
				REV J