

FEATURES

Complete RF Detector/Controller Function
Selectable Dual Outputs
49 dB Range at 0.9 GHz (-47.6 dBm to +1.5 dBm re 50 Ω)
Accurate Scaling from 0.1 GHz to 2.5 GHz
Temperature-Stable Linear-in-dB Response
Log Slope of 22 mV/dB
True Integration Function in Control Loop
Low Power: 23 mW at 2.7 V
Power-Down to 11 μ W

APPLICATIONS

Single-Band, Dual-Band, and Triband Mobile Handsets
(GSM, DCS, PCS, EDGE)
Wireless Terminal Devices
Transmitter Power Control

GENERAL DESCRIPTION

The AD8316 is a complete, low cost subsystem for the precise control of dual RF power amplifiers (PAs) operating in the frequency range 0.1 GHz to 2.5 GHz and over a typical dynamic range of 50 dB. The device is a dual-output version of the AD8315 and intended for use in dual-band or triband cellular handsets and other battery-operated wireless devices where a separate

power control signal is required for each band. The logarithmic amplifier technique provides a much wider measurement range and better accuracy than is possible using controllers based on diode detectors. In particular, multiband and multimode cellular designs can benefit from the temperature-stable (-30°C to $+85^{\circ}\text{C}$) operation over all cellular telephony frequencies.

Its high sensitivity allows control at low input signal levels, thus reducing the amount of power that needs to be coupled to the detector. The selected output, OUT1 or OUT2, has the voltage range and current drive to directly connect to the gain control pin of most handset power amplifiers; the deselected output is pulled low to ensure that the inactive PA remains off. Each output has a dedicated integrating filter capacitor that allows separate control loop settings for each PA. OUT1 and OUT2 can swing from 125 mV above ground to within 100 mV below the supply voltage. Load currents of up to 12 mA can be supported.

The setpoint control input applied to pin VSET has an operating range of 0.25 V to 1.4 V. The input resistance of the setpoint interface is over 100 M Ω , and the bias current is typically 0.5 μ A.

The AD8316 is available in 10-lead MSOP and 16-lead LFCSP packages and consumes 8.5 mA from a 2.7 V to 5.5 V supply. When it is powered down, the sleep current is 4 μ A.

FUNCTIONAL BLOCK DIAGRAM

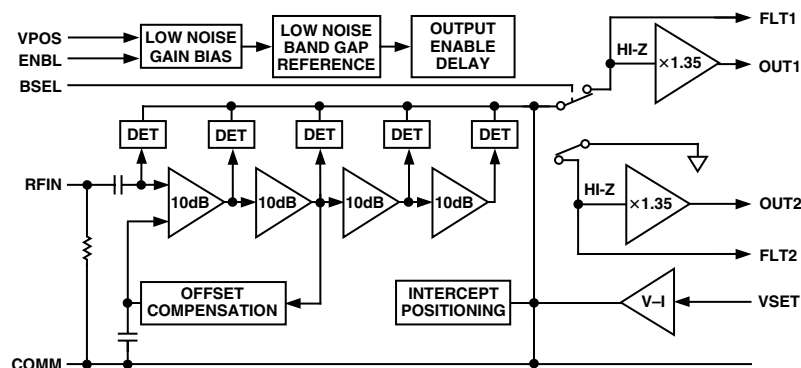

REV. C

Information furnished by Analog Devices is believed to be accurate and reliable. However, no responsibility is assumed by Analog Devices for its use, nor for any infringements of patents or other rights of third parties that may result from its use. No license is granted by implication or otherwise under any patent or patent rights of Analog Devices. Trademarks and registered trademarks are the property of their respective owners.

AD8316—SPECIFICATIONS ($V_{POS} = 2.7\text{ V}$, $T_A = 25^\circ\text{C}$, $52.3\ \Omega$ on RFIN, unless otherwise noted.)

Parameter	Conditions	Min	Typ	Max	Unit
OVERALL FUNCTION					
Frequency Range ¹	To Meet All Specifications	0.1		2.5	GHz
Input Voltage Range	$\pm 1\text{ dB}$ Log Conformance, 0.1 GHz	-58.6		-10	dBV
Equivalent dBm Range		-45.6		+3	dBm
Logarithmic Slope ^{2,3}	0.1 GHz	20.5	22.1	24.5	mV/dB
Logarithmic Intercept ^{2,3}	0.1 GHz	-68	-74	-78	dBV
Equivalent dBm Level		-55	-61	-65	dBm
RF INPUT INTERFACE					
Input Resistance ⁴	Pin RFIN 0.1 GHz		2.9		k Ω
Input Capacitance ⁴	0.1 GHz		1.0		pF
OUTPUTS					
Minimum Output Voltage	Pins OUT1 and OUT2 VSET $\leq 200\text{ mV}$, ENBL High, RF Input $\leq -60\text{ dBm}$ ENBL Low	0.1	0.15 0.025	0.25	V V
Maximum Output Voltage	$R_L > 800\ \Omega$	2.45		2.6	V
General Limit	$2.7\text{ V} \leq V_{POS} \leq 5.5\text{ V}$		$V_{POS} - 0.1$		V
Output Current Drive	Source			12	mA
Output Buffer Noise			25		nV/ $\sqrt{\text{Hz}}$
Output Noise	RF Input = 2 GHz, 0 dBm, $C_{FLT} = 220\text{ pF}$, $f_{NOISE} = 400\text{ kHz}$		100		nV/ $\sqrt{\text{Hz}}$
Small Signal Bandwidth	0.2 V to 2.6 V Swing		30		MHz
Slew Rate	10%–90%, 250 mV Step (V_{SET}), Open Loop ⁵		20		V/ μs
Full-Scale Response Time	FLTR = Open; Refer to TPC 28		50		ns
SETPOINT INTERFACE					
Nominal Input Range	Pin VSET Corresponding to Central 50 dB	0.25		1.5	V
Logarithmic Scale Factor			43.5		dB/V
Input Resistance			100		k Ω
Slew Rate			16		V/ μs
ENABLE INTERFACE					
Logic Level to Enable Power	Pin ENBL	1.8		V_{POS}	V
Input Current when Enable High			20		μA
Logic Level to Disable Power				0.8	V
Enable Time	Time from ENBL High to V_{APC} within 1% of Final Value, $C_{FLT} = 68\text{ pF}$; Refer to TPC 20		7		μs
Disable Time	Time from ENBL Low to V_{APC} within 1% of Final Value, $C_{FLT} = 68\text{ pF}$; Refer to TPC 20		3		μs
Power-On/Enable Time	Time from VPOS/ENBL Low to V_{APC} within 1% of Final Value, $C_{FLT} = 68\text{ pF}$; Refer to TPC 25		3		μs
Power-Off/Disable Time	Time from VPOS/ENBL High to V_{APC} within 1% of Final Value, $C_{FLT} = 68\text{ pF}$; Refer to TPC 25		4		μs
BAND SELECT INTERFACE					
Logic Level to Enable OUT1	Pin BSEL	1.8		V_{POS}	V
Input Current when BSEL High			50		μA
Logic Level to Enable OUT2		0.0		1.7	V
POWER INTERFACE					
Supply Voltage	Pin VPOS	2.7		5.5	V
Quiescent Current	ENBL High		8.5	10.7	mA
Over Temperature	$-30^\circ\text{C} \leq T_A \leq +85^\circ\text{C}$			12	mA
Disable Current ⁶	ENBL Low		3	10	μA
Over Temperature	$-30^\circ\text{C} \leq T_A \leq +85^\circ\text{C}$			13	μA

NOTES

¹Operation down to 0.02 GHz is possible.

²Calculated over the input range of -40 dBm to -10 dBm.

³Mean and standard deviation specifications are in Table I.

⁴See TPC 9 for plot of Input Impedance vs. Frequency.

⁵Response time in a closed-loop system will depend upon the filter capacitor (C_{FLT}) used and the response of the variable gain element.

⁶This parameter is guaranteed but not tested in production. The maximum specified limit on this parameter is the +6 sigma value from characterization.

Specifications subject to change without notice.

Table I. Typical Specifications at Selected Frequencies at 25°C

Frequency (GHz)	Slope (mV/dB)		Intercept (dBm)		Dynamic Range Low Point (dBm)		Dynamic Range High Point (dBm)	
	Mean	Standard Deviation	Mean	Standard Deviation	Mean	Standard Deviation	Mean	Standard Deviation
0.1	22.1	0.3	-61.0	1.5	-45.6	0.7	3.0	0.7
0.9	22.2	0.3	-62.2	1.5	-47.6	0.6	1.5	0.6
1.9	21.6	0.3	-63.1	1.5	-49.2	0.8	-4.5	0.8
2.5	21.3	0.3	-66.0	1.6	-51.5	1.1	-3.0	1.1

Slope and intercept calculated over the input amplitude range of -40 dBm to -10 dBm.

ABSOLUTE MAXIMUM RATINGS*

Supply Voltage VPOS	5.5 V
OUT1, OUT2, VSET, ENBL	0 V, VPOS
RFIN	17 dBm
Equivalent Voltage	1.6 V
Internal Power Dissipation	100 mW
θ_{JA} (MSOP)	200°C/W
θ_{JA} (LFCSP, Paddle soldered)	80°C/W
θ_{JA} (LFCSP, Paddle not soldered)	130°C/W
Maximum Junction Temperature	125°C
Operating Temperature Range	-40°C to +85°C

Storage Temperature Range	-65°C to +150°C
Lead Temperature Range (Soldering 60 sec)	
MSOP	300°C
LFCSP	240°C

*Stresses above those listed under Absolute Maximum Ratings may cause permanent damage to the device. This is a stress rating only; functional operation of the device at these or any other conditions above those indicated in the operational section of this specification is not implied. Exposure to absolute maximum rating conditions for extended periods may affect device reliability.

PIN FUNCTION DESCRIPTIONS

PIN CONFIGURATION

10-Lead MSOP

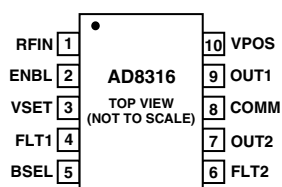

16-Lead LFCSP

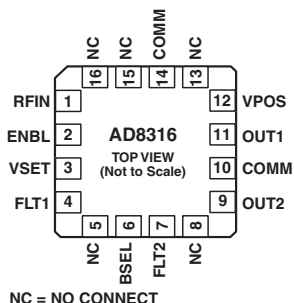

Pin No.		Mnemonic	Function
MSOP	LFCSP		
1	1	RFIN	RF Input.
2	2	ENBL	Connect to VPOS for Normal Operation. Connect pin to ground for disable mode.
3	3	VSET	Setpoint Input.
4	4	FLT1	Integrator Capacitor for OUT1. Connect between FLT1 and COMM.
5	6	BSEL	Band Select. LO = OUT2, HI = OUT1.
6	7	FLT2	Integrator Capacitor for OUT2. Connect between FLT2 and COMM.
7	9	OUT2	Band 2 Output.
8	10, 14	COMM	Device Common (Ground).
9	11	OUT1	Band 1 Output.
10	12	VPOS	Positive Supply Voltage: 2.7 V to 5.5 V.
	5, 8, 13, 15, 16	NC	No Connection.

ORDERING GUIDE

Model	Temperature Range	Package Description	Package Option	Branding
AD8316ARM	-30°C to +85°C	10-Lead MSOP, Tube	RM-10	J8A
AD8316ARM-REEL7	-30°C to +85°C	MSOP, 7" Tape and Reel	RM-10	J8A
AD8316-EVAL		MSOP Evaluation Board		
AD8316ACP-REEL	-30°C to +85°C	16-Lead LFCSP, 13" Tape and Reel	CP-16-3	J8A
AD8316ACP-REEL7	-30°C to +85°C	LFCSP, 7" Tape and Reel	CP-16-3	J8A
AD8316ACP-EVAL		LFCSP Evaluation Board		

CAUTION

ESD (electrostatic discharge) sensitive device. Electrostatic charges as high as 4000 V readily accumulate on the human body and test equipment and can discharge without detection. Although the AD8316 features proprietary ESD protection circuitry, permanent damage may occur on devices subjected to high energy electrostatic discharges. Therefore, proper ESD precautions are recommended to avoid performance degradation or loss of functionality.



AD8316—Typical Performance Characteristics

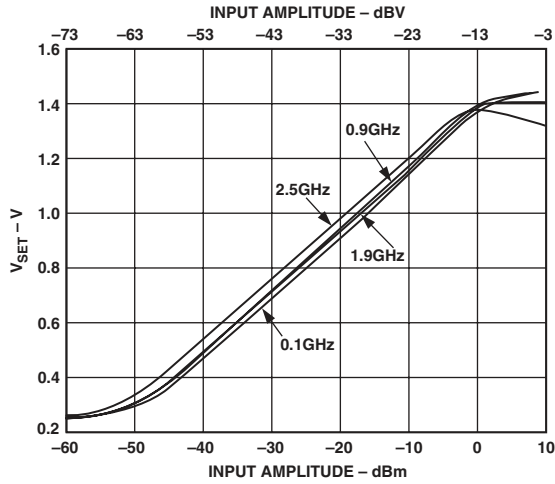

TPC 1. V_{SET} vs. Input Amplitude

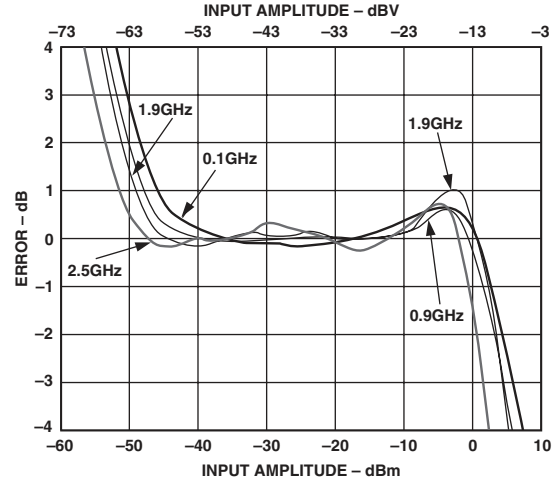

TPC 4. Log Conformance vs. Input Amplitude at Selected Frequencies

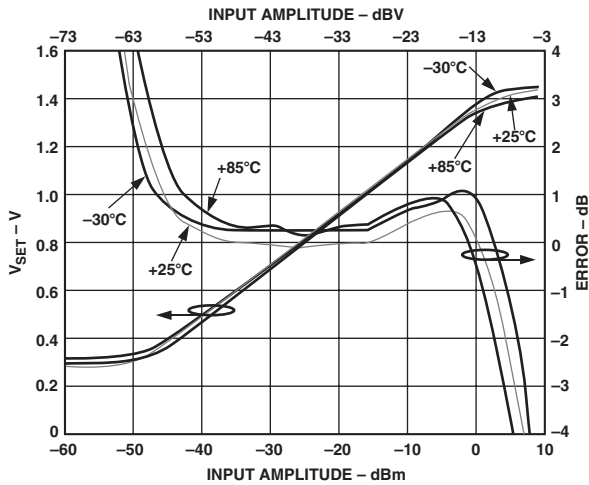

TPC 2. V_{SET} and Log Conformance vs. Input Amplitude at 0.1 GHz

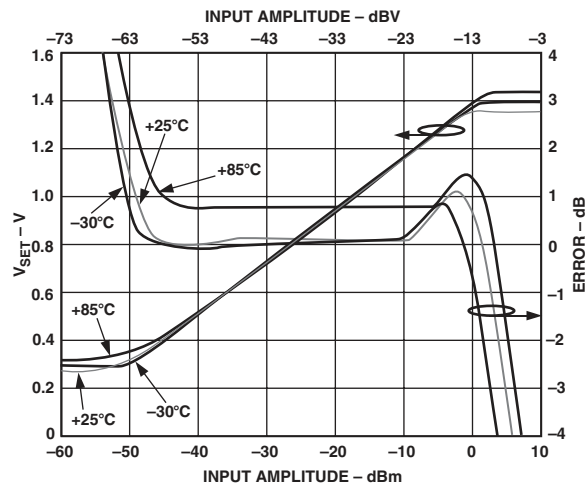

TPC 5. V_{SET} and Log Conformance vs. Input Amplitude at 1.9 GHz

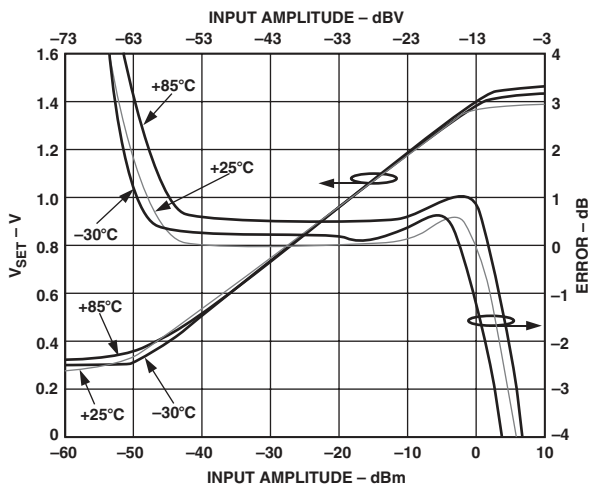

TPC 3. V_{SET} and Log Conformance vs. Input Amplitude at 0.9 GHz

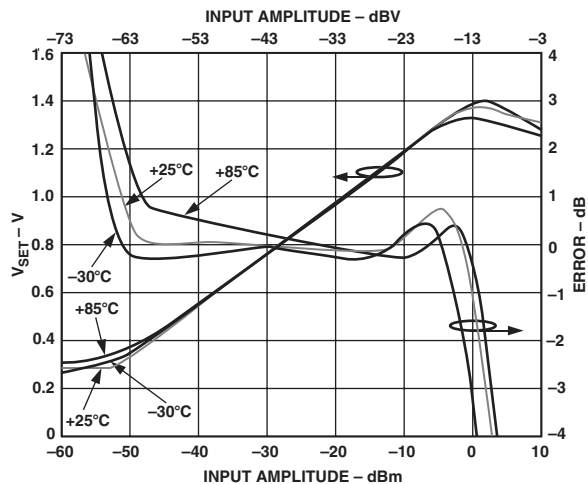

TPC 6. V_{SET} and Log Conformance vs. Input Amplitude at 2.5 GHz

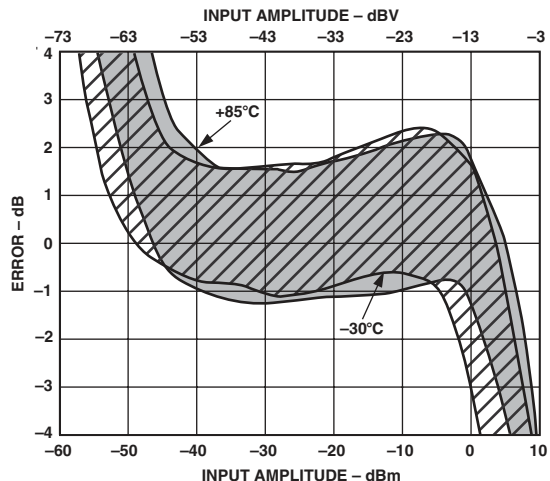

TPC 7. Distribution of Error at Temperature after Ambient Normalization vs. Input Amplitude, 3 Sigma to Either Side of Mean, 0.1 GHz

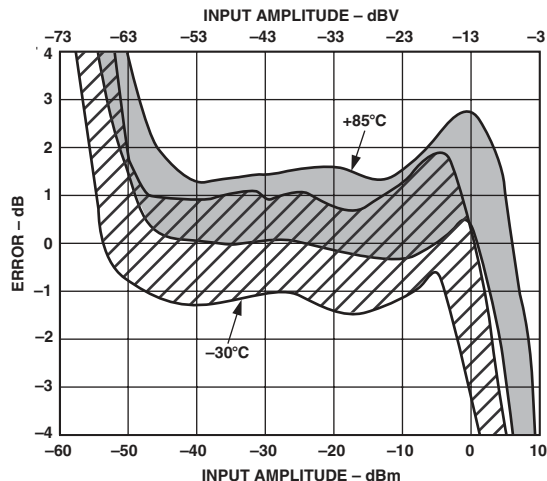

TPC 10. Distribution of Error at Temperature after Ambient Normalization vs. Input Amplitude, 3 Sigma to Either Side of Mean, 1.9 GHz

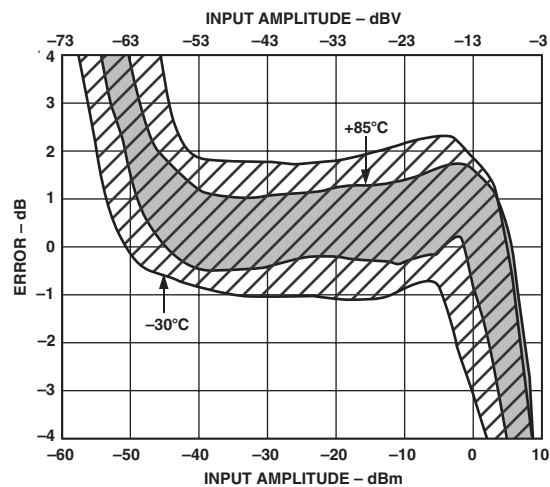

TPC 8. Distribution of Error at Temperature after Ambient Normalization vs. Input Amplitude, 3 Sigma to Either Side of Mean, 0.9 GHz

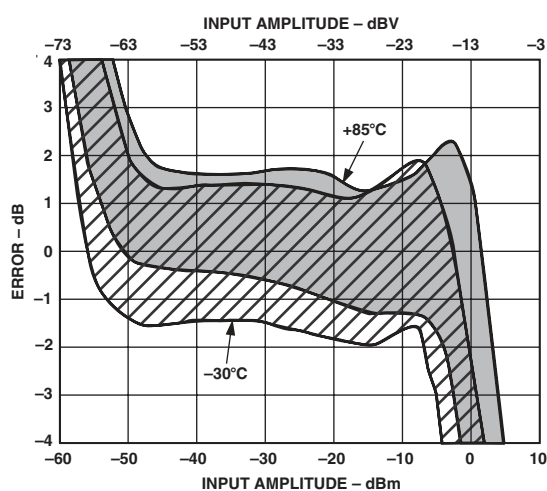

TPC 11. Distribution of Error at Temperature after Ambient Normalization vs. Input Amplitude, 3 Sigma to Either Side of Mean, 2.5 GHz

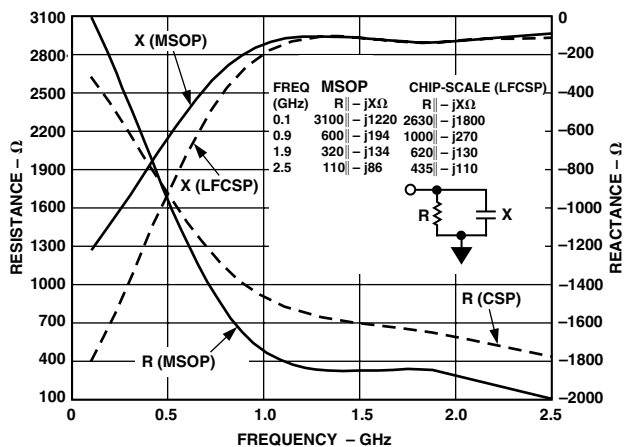

TPC 9. Input Impedance vs. Frequency

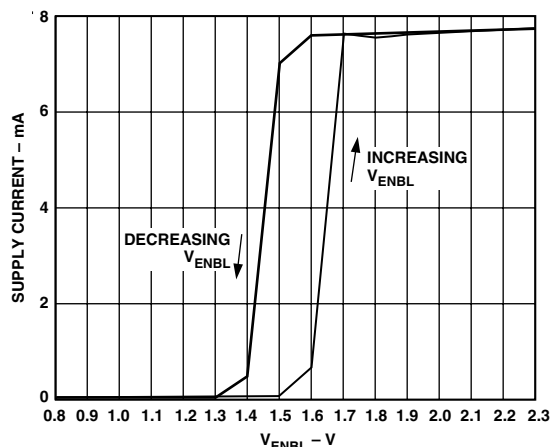

TPC 12. Supply Current vs. V_{ENBL}

AD8316

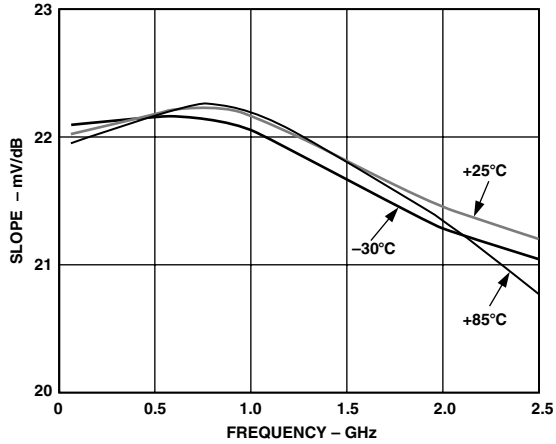

TPC 13. Slope vs. Frequency at Selected Temperatures

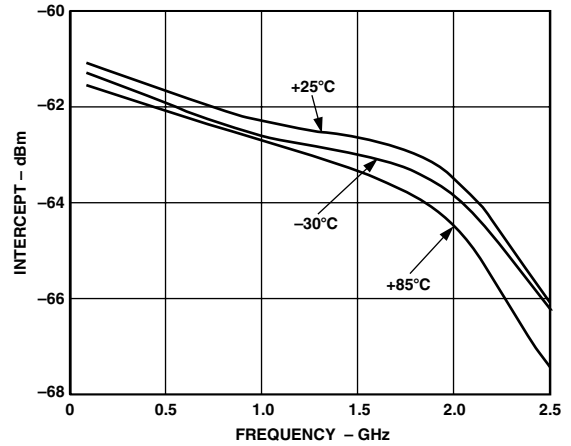

TPC 16. Intercept vs. Frequency at Selected Temperatures

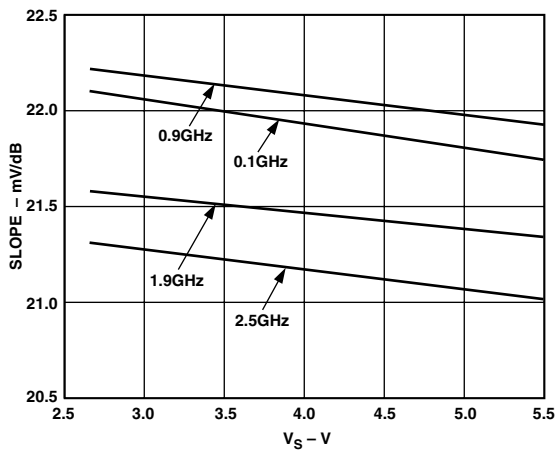

TPC 14. Slope vs. Supply Voltage

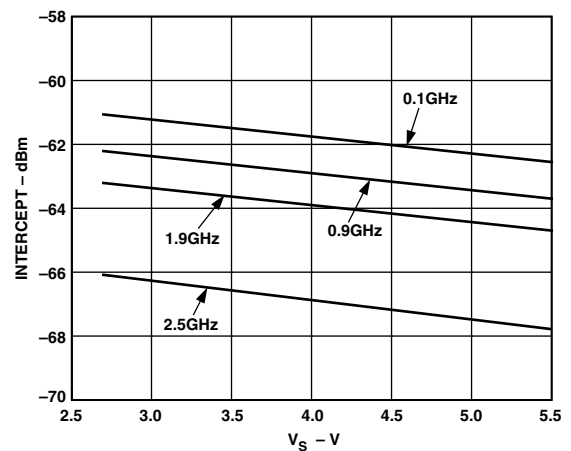

TPC 17. Intercept vs. Supply Voltage

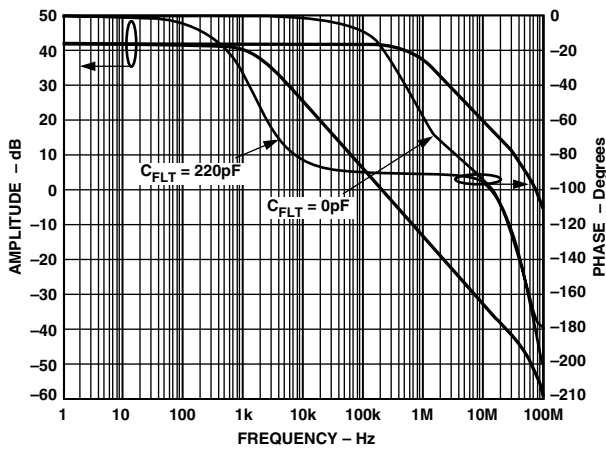

TPC 15. AC Response from VSET to OUT1 and OUT2

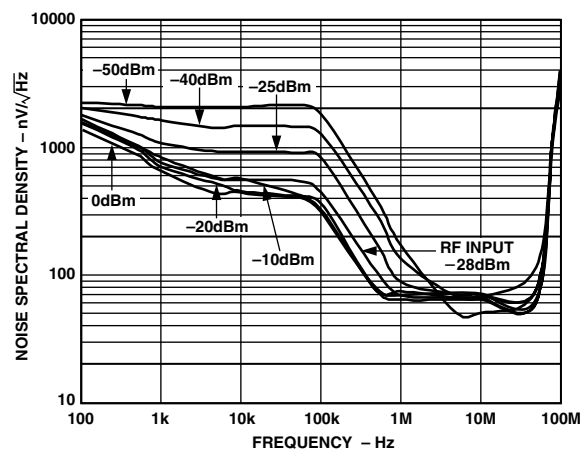

TPC 18. Output Noise Spectral Density, $R_L = \infty$, $C_{FLT} = 220 \text{ pF}$, by RF Input Amplitude

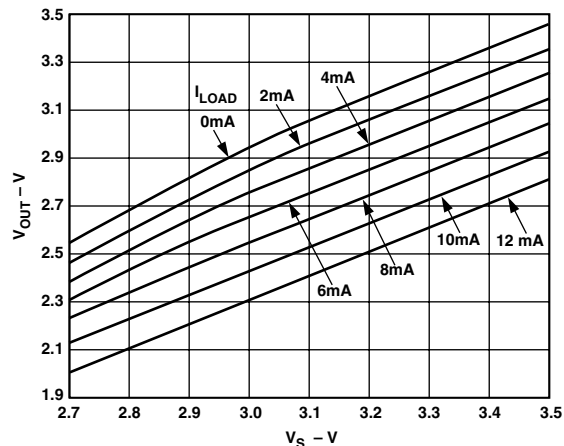

TPC 19. Maximum OUT Voltage vs. Supply Voltage by Load Current, AD8316 Sourcing

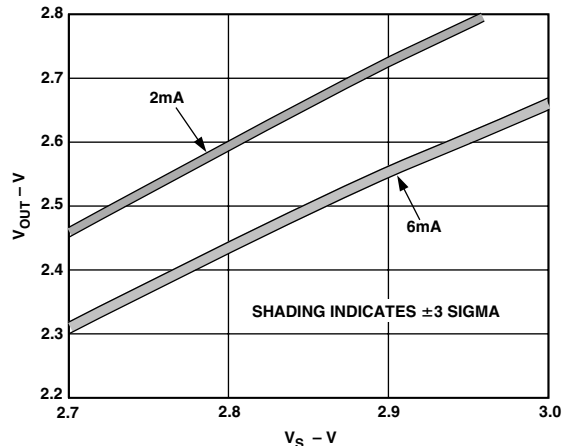

TPC 22. Distribution of Maximum OUT Voltage vs. Supply Voltage with 2 mA and 6 mA Loads, 3 Sigma to Either Side of Mean, AD8316 Sourcing

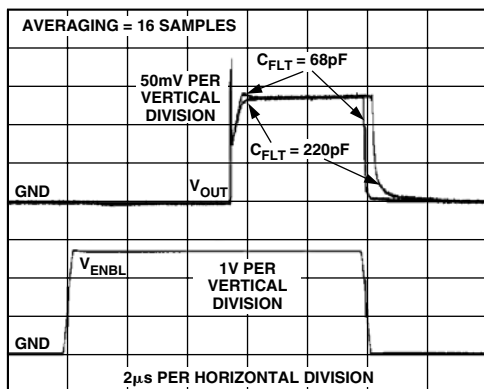

TPC 20. ENBL Response Time, Rise/Fall Time = 250 ns

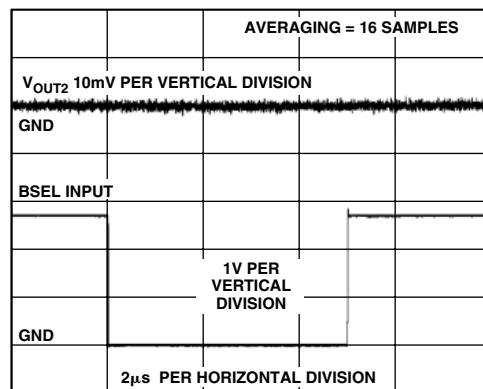

TPC 23. BSEL Response Time, ENBL Grounded

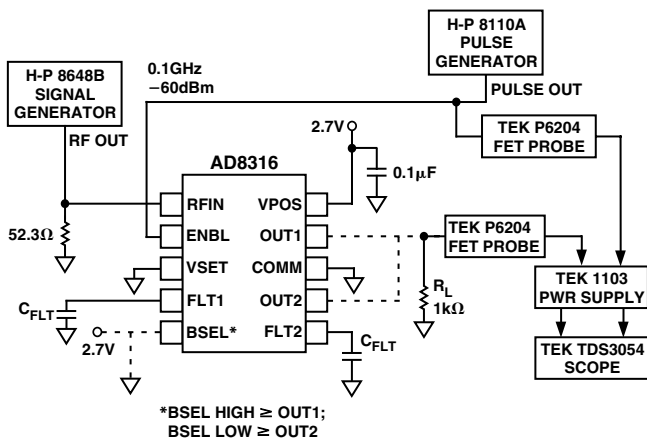

TPC 21. Test Setup for ENBL Response Time

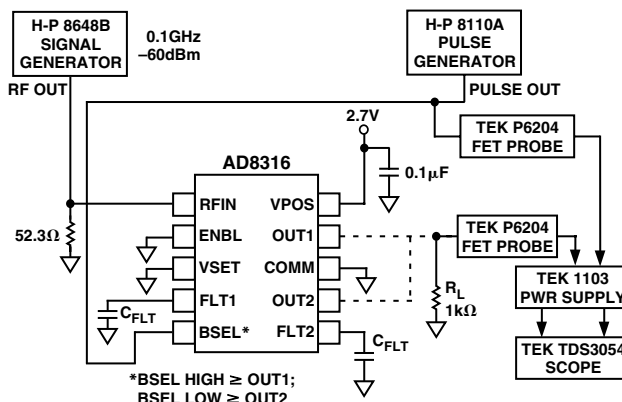

TPC 24. Test Setup for BSEL Response Time

AD8316

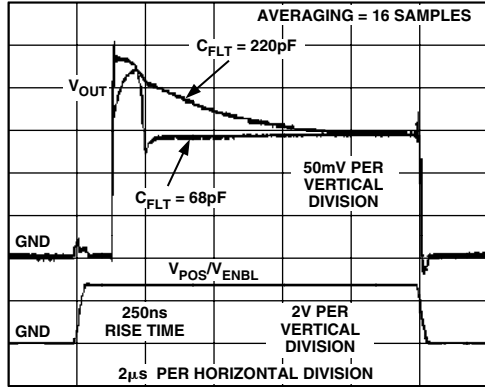

TPC 25. Power-On and Power-Off Response with VSET Grounded, Rise/Fall Time = 250 ns

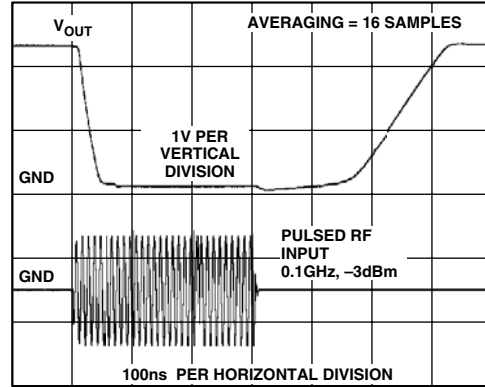

TPC 28. Pulse Response Time, Full-Scale Amplitude Change, Open Loop, $C_{FLT} = 0$ pF

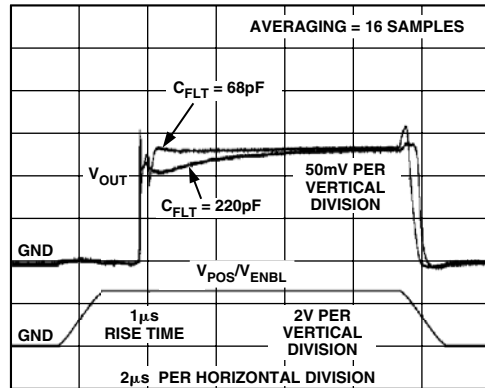

TPC 26. Power-On and Power-Off Response with VSET Grounded, Rise/Fall Time = 1 μ s

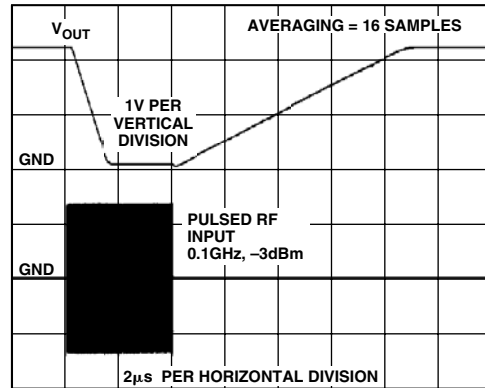

TPC 29. Pulse Response Time, Full-Scale Amplitude Change, Open Loop, $C_{FLT} = 68$ pF

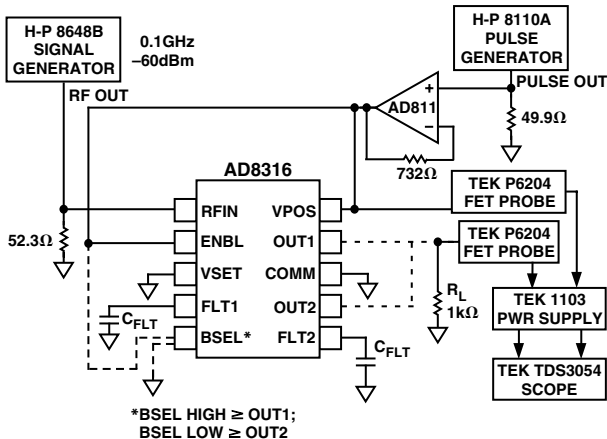

TPC 27. Test Setup for Power-On and Power-Off Response with VSET Grounded

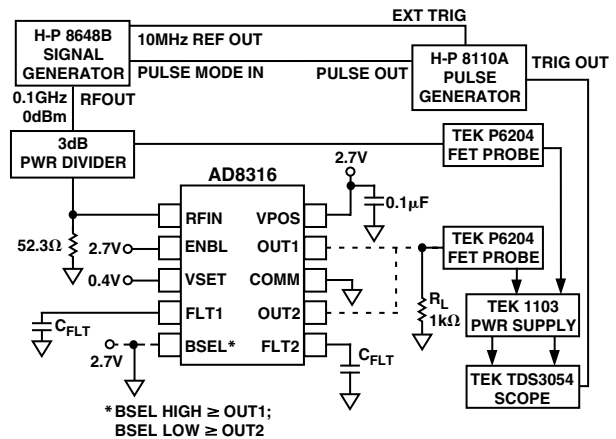

TPC 30. Test Setup for Pulse Response Time

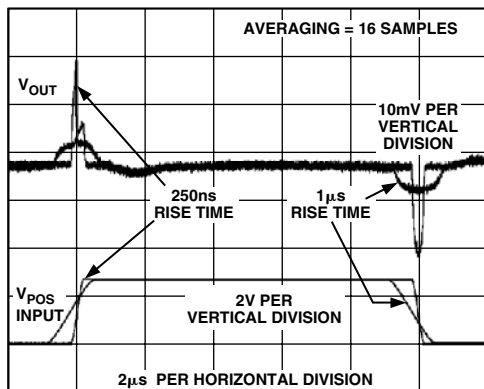

TPC 31. Power-On and Power-Off Response with VSET and ENBL Grounded

amplifiers. When the band select pin, BSEL, directs one of the controller outputs to servo its amplifier toward the setpoint indicated by the power control pin VSET, the other output is forced to ground, disabling the second amplifier. Each output has a dedicated filter pin, FLT1 and FLT2, that allows the filtering and loop dynamics for each control loop to be optimized independently.

Basic Theory

Logarithmic amplifiers provide a type of compression in which a signal with a large range of amplitudes is converted to one of a smaller range. The use of the logarithmic function uniquely results in the output representing the decibel value of the input. The fundamental mathematical form is

$$V_{OUT} = V_{SLP} \log \frac{V_{IN}}{V_Z} \quad (1)$$

Here V_{IN} is the input voltage and V_Z is called the intercept (voltage) because when $V_{IN} = V_Z$ the argument of the logarithm is unity, and thus the result is zero; V_{SLP} is called the slope (voltage), which is the amount by which the output changes for a certain change in the ratio (V_{IN}/V_Z).

Because log amps do not respond to power, but only to voltages, and the calibration of the intercept is waveform dependent and only quoted for a sine wave signal, the *equivalent power response* can be written as

$$V_{OUT} = V_{DB} (P_{IN} - P_Z) \quad (2)$$

where the input power P_{IN} and the equivalent intercept P_Z are both expressed in dBm (thus, the quantity in the parentheses is simply a number of decibels), and V_{DB} is the slope expressed as so many mV/dB. When base 10 logarithms are used, denoted by the function \log_{10} , V_{SLP} represents V/dec, and since a decade corresponds to 20 dB, $V_{SLP}/20$ represents the change in V/dB. For the AD8316, a nominal (low frequency) slope of 22 mV/dB (corresponding to a V_{SLP} of $0.022 \text{ mV/dB} \times 20 \text{ dB} = 440 \text{ mV}$) was chosen, and the intercept V_Z was placed at the equivalent of -74 dBV , or $199 \text{ } \mu\text{V rms}$, for a sine wave input. This corresponds to a power level of -61 dBm when the net resistive part of the input impedance of the log amp is $50 \text{ } \Omega$. However, both the slope and the intercept are dependent on frequency (see for example, TPC 13 and TPC 16).

For a log amp with a slope V_{DB} of $+22 \text{ mV/dB}$ and an intercept at -61 dBm , the output voltage for an input power of -30 dBm is $0.022 \times (-30 - [-61]) = 0.682 \text{ V}$.

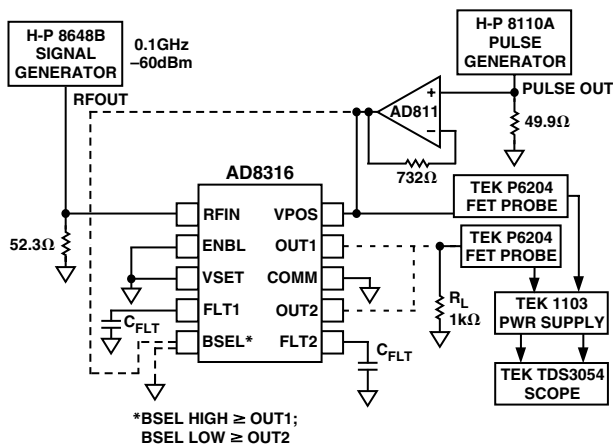

TPC 32. Test Setup for Power-On and Power-Off Response with VSET and ENBL Grounded

GENERAL DESCRIPTION AND THEORY

The AD8316 is a wideband logarithmic amplifier (log amp) with two selectable outputs suitable for dual-band/dual-mode power amplifier control. It is strictly optimized for power control applications rather than for use as a measurement device. Figure 1 shows its main features in block schematic form. The output pins, OUT1 and OUT2, are intended to be applied directly to the automatic power control (APC) pins of two distinct power

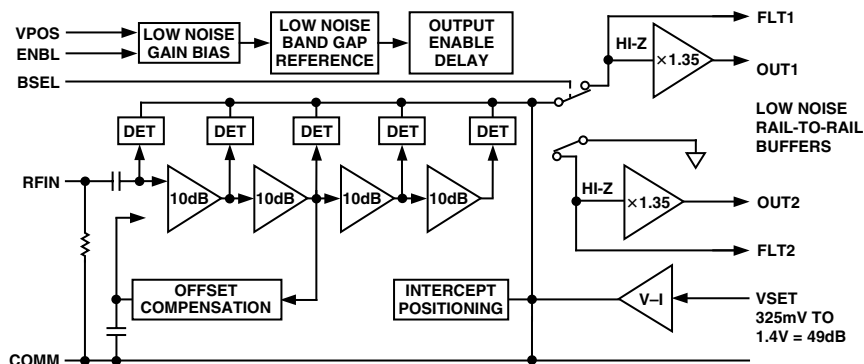

Figure 1. Block Schematic of the AD8316

AD8316

Further details about the structure and function of log amps are provided in data sheets for other log amps produced by Analog Devices. The AD640 and AD8307 include detailed discussions of the basic principles of operation and explain why the intercept depends on waveform, an important consideration when complex modulation is imposed on an RF carrier.

The intercept need not correspond to a physically realizable part of the signal range for the log amp. Thus, for the AD8316, the specified intercept is -62 dBm at 0.9 GHz, whereas the lowest acceptable input for accurate measurement ($+1$ dB error) is -48 dBm. At 2.5 GHz, the $+1$ dB error point shifts to -52 dBm. This positioning of the intercept is deliberate and ensures that the VSET voltage is within the capabilities of certain DACs, whose outputs cannot swing below 200 mV. Figure 2 shows the 0.9 GHz response of the AD8316; the vertical axis represents the value required at the power control pin VSET to null the control loop rather than the voltage at the OUT1 or OUT2 pins.

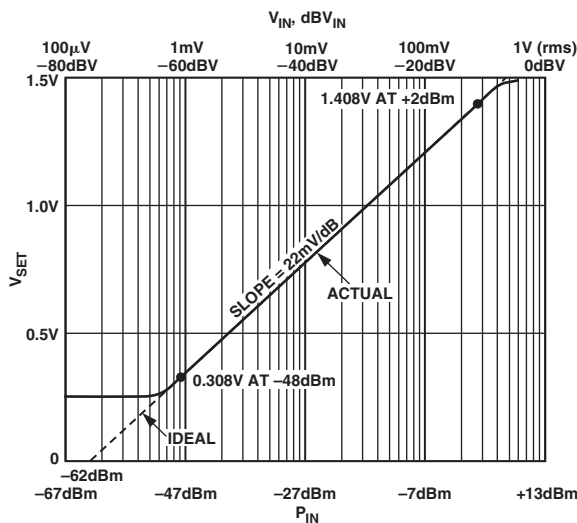

Figure 2. Basic Calibration of the AD8316 at 0.9 GHz

Controller-Mode Log Amps

The AD8316 combines the two key functions required for the measurement and control of the power level over a moderately wide dynamic range. First, it provides the amplification needed to respond to small signals with a chain of four amplifier/limiter cells, each with a small signal gain of 10 dB and a bandwidth of approximately 4 GHz (see Figure 1). At the output of each of these amplifier stages is a full-wave rectifier, essentially a square-law detector cell that converts the RF signal voltages to a fluctuating current having an average value that increases with signal level. A passive detector stage is added ahead of the first stage. These five detectors are separated by 10 dB, spanning 50 dB of dynamic range. Their outputs are in the form of a differential current, making summation a simple matter. It is readily shown that the summed output can closely approximate a logarithmic function. The overall accuracy at the extremes of the total range, viewed as the deviation from an ideal logarithmic response, that is, the law-conformance error, can be judged by referring to TPC 4, which shows that errors across the central 40 dB are moderate. Other performance curves show how conformance to an ideal logarithmic function varies with supply voltage, temperature, and frequency.

In a device intended for measurement applications, this current would be converted to an equivalent voltage to provide the $\log(V_{IN})$ function shown in Equation 1. However, the design of the AD8316 differs from standard practice in that its output needs to be a low noise control voltage for an RF power amplifier, not a direct measure of the input level. Further, it is highly desirable that this voltage be proportional to the time integral of the error between the actual input V_{IN} and a dc voltage V_{SET} (applied to Pin 3, VSET) that defines the setpoint, that is, a target value for the power level, typically generated by a DAC.

This is achieved by converting the difference between the sum of the detector outputs (still in current form) and an internally generated current proportional to V_{SET} to a single-sided current-mode signal. This, in turn, is converted to a voltage (at FLT1 or FLT2, the low-pass filter capacitor nodes) to provide a close approximation to an exact integration of the error between the power present in the termination at the input of the AD8316 and the setpoint voltage. Finally, the voltages developed across the ground referenced filter capacitors C_{FLT} are buffered by a special low noise amplifier of low voltage gain ($\times 1.35$) and presented at OUT2 or OUT1 for use as the control voltage for the appropriate RF power amplifier. This buffer can provide rail-to-rail swings and can drive a substantial load current, including large capacitors. Note: *The RF power delivered by the power amplifier is assumed to increase monotonically with an increasingly positive voltage on its APC control pin.*

Band selection in the AD8316 relies on the fact that dual-band/dual-mode amplifier systems require only one active amplifier at a time. This allows both amplifier outputs to share the RF input of the AD8316 (Pin 1, RFIN) as long as the inactive amplifier is disabled, i.e., it is not delivering RF power. In this case, power control is directed solely through the selected amplifier. The AD8316 ensures that the output control pin associated with the unselected amplifier pulls its APC pin to ground. It is assumed that the amplifier is essentially disabled when its APC pin is grounded.

Control Loop Dynamics

To understand how the AD8316 behaves in a complete control loop, it is necessary to develop an expression for the current in the integration capacitor as a function of the input V_{IN} and the setpoint voltage V_{SET} . Refer to Figure 3.

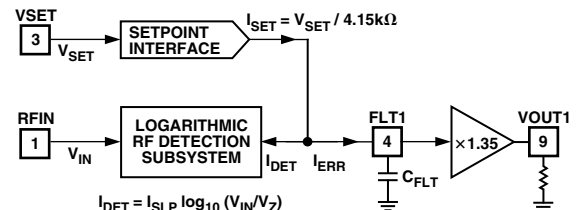

Figure 3. Behavioral Model for the AD8316 with OUT1 Selected

First, write the summed detector currents as a function of the input:

$$I_{DET} = I_{SLP} \log_{10} (V_{IN} / V_Z) \quad (3)$$

where I_{DET} is the partially filtered demodulated signal, whose exact average value will be extracted through the subsequent integration step; I_{SLP} is the current-mode slope, and has a value of 106 mA per decade (that is, 5.3 mA/dB); V_{IN} is the input in

volts rms; and V_Z is the effective intercept voltage, which, as previously noted, is dependent on waveform but is 199 μV rms for a sine wave input. Now, the current generated by the setpoint interface is simply

$$I_{SET} = V_{SET}/4.15 \text{ k}\Omega \quad (4)$$

I_{ERR} , the difference between this current and I_{DET} , is applied to the loop filter capacitor C_{FLT} . It follows that the voltage appearing on this capacitor, V_{FLT} , is the time integral of the difference current

$$V_{FLT}(s) = (I_{SET} - I_{DET})/sC_{FLT} \quad (5)$$

$$= \frac{V_{SET}/4.15 \text{ k}\Omega - I_{SLP} \log_{10}(V_{IN}/V_Z)}{sC_{FLT}} \quad (6)$$

The control output V_{OUT} is slightly greater than this, since the gain of the output buffer is $\times 1.35$. Also, an offset voltage is deliberately introduced in this stage, but this is inconsequential, since the integration function implicitly allows for an arbitrary constant to be added to the form of Equation 6. The polarity is such that V_{OUT} will rise to its maximum value for any value of V_{SET} greater than the equivalent value of V_{IN} . In practice, the output will rail to the positive supply under this condition unless the control loop through the power amplifier is present. In other words, the AD8316 seeks to drive the RF power to its maximum value whenever it falls below the setpoint. The use of exact integration results in a final error that is theoretically zero, and the logarithmic detection law would ideally result in a constant response time following a step change of either the setpoint or the power level, if the power amplifier control function were likewise "linear-in-dB." This latter condition is rarely true, however, and it follows that the loop response time will, in practice, depend on the power level, and this effect can strongly influence the design of the control loop.

Equation 6 can be clarified by noting that it can be restated in the following way

$$V_{OUT}(s) = \frac{V_{SET} - V_{SLP} \log_{10}(V_{IN}/V_Z)}{sT} \quad (7)$$

where V_{SLP} is the volts-per-decade slope from Equation 1, having a value of 440 mV/dec, and T is an effective time constant for the integration, being equal to $(4.15 \text{ k}\Omega \times C_{FLT})/1.35$; the resistor value comes from the setpoint interface scaling Equation 4 and the factor 1.35 arises as a result of the voltage gain of the buffer. So the integration time constant can be written as

$$T = 3.07 \times C_{FLT} \quad (8)$$

(in μs when C_{FLT} is expressed in nF)

To simplify understanding of the control loop dynamics, begin by assuming that the power amplifier gain function actually is linear-in-dB; for now, we will also use voltages to express the signals at the power amplifier input and output. Let the RF output voltage be V_{PA} and its input be V_{CW} ; further, to characterize the gain control function, this form is used

$$V_{PA} = G_O V_{CW} 10^{(V_{OUT}/V_{GSC})} \quad (9)$$

where G_O is the gain of the power amplifier when $V_{OUT} = 0$ and V_{GSC} is the gain scaling. While few amplifiers will conform so conveniently to this law, it nevertheless provides a clearer starting

point for understanding the more complex situation that arises when the gain control law is less than ideal.

This idealized control loop is shown in Figure 4. With some manipulation, it is found that the characteristic equation of this system is

$$V_{OUT}(s) = \frac{(V_{SET} V_{GSC})/V_{SLP} - V_{GSC} \log_{10}(kG_O V_{CW}/V_Z)}{1 + sT_O} \quad (10)$$

where k is the voltage coupling factor from the output of the power amplifier to the input of the AD8316 (e.g., $\times 0.1$ for a 20 dB coupler) and T_O is a modified time constant $(V_{GSC}/V_{SLP})T$.

This is quite easy to interpret. First, it shows that a system of this sort will exhibit a simple single-pole response, for any power level, with the customary exponential time domain form for either increasing or decreasing step polarities in the demand level V_{SET} or the carrier input V_{CW} . Second, it reveals that the final value of the control voltage V_{OUT} will be determined by several fixed factors

$$V_{OUT}(t = \infty) = (V_{SET} V_{GSC})/V_{SLP} - V_{GSC} \log_{10}(kG_O V_{CW}/V_Z) \quad (11)$$

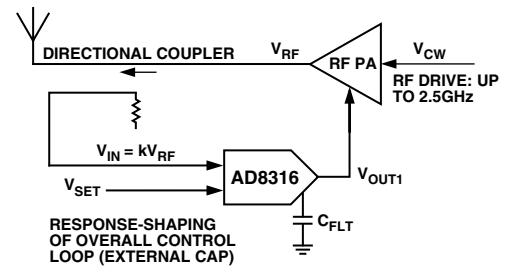

Figure 4. Idealized Control Loop for Dynamic Analysis, OUT1 Selected

Example

Assume that the gain magnitude of the power amplifier runs from a minimum value of $\times 0.316$ (-10 dB) at $V_{OUT} = 0$ to $\times 100$ (40 dB) at $V_{OUT} = 2.5$ V. Applying Equation 9, we find $G_O = 0.316$ and $V_{GSC} = 1$ V. Using a coupling factor of $k = 0.0316$ (that is, a 30 dB directional coupler) and recalling that the nominal value of V_{SLP} is 440 mV and $V_Z = 199$ μV for the AD8316, we will first calculate the range of values needed for V_{SET} to control an output range of $+32$ dBm to -17 dBm. Note that, in the steady state, the numerator of Equation 7 must be zero, that is

$$V_{SET} = V_{SLP} \log_{10}(kV_{PA}/V_Z) \quad (12)$$

when V_{IN} is expanded to kV_{PA} , the fractional voltage sample of the power amplifier output. Now, for $+32$ dBm, $V_{PA} = 8.9$ V rms, this evaluates to

$$V_{SET}(max) = 0.44 \log_{10}(281 \text{ mV}/199 \mu\text{V}) = 1.39 \text{ V} \quad (13)$$

For a delivered power of -17 dBm, $V_{PA} = 31.6$ mV rms,

$$V_{SET}(min) = 0.44 \log_{10}(1.0 \text{ mV}/199 \mu\text{V}) = 0.310 \text{ V} \quad (14)$$

Note: The power range is 49 dB, which corresponds to a voltage change of $49 \text{ dB} \times 22 \text{ mV/dB} = 1.08$ V in V_{SET} .

AD8316

The value of V_{OUT} is of interest, although it is a dependent parameter inside the loop. It depends on the characteristics of the power amplifier, and the value of the carrier amplitude V_{CW} .

Using the control values derived above, that is, $G_O = 0.316$ and $V_{GSC} = 1$ V, and assuming that the applied power is fixed at -7 dBm (so that $V_{CW} = 100$ mV rms), Equation 11 shows

$$\begin{aligned} V_{OUT}(max) &= (V_{SET}V_{GSC})/V_{SLP} - \log_{10} (kG_OV_{CW}/V_Z) \\ &= (1.39 \times 1)/0.44 - \log_{10} \left(\frac{0.0316 \times 0.316 \times}{0.1/199 \mu V} \right) \\ &= 3.2 - 0.7 = 2.5 V \end{aligned} \quad (15)$$

$$\begin{aligned} V_{OUT}(min) &= (V_{SET}V_{GSC})/V_{SLP} - \log_{10} (kG_OV_{CW}/V_Z) \\ &= (0.31 \times 1)/0.44 - \log_{10} \left(\frac{0.0316 \times 0.316 \times}{0.1/199 \mu V} \right) \\ &= 0.7 - 0.7 = 0 \end{aligned} \quad (16)$$

Both results are consistent with the assumptions made about the amplifier control function. Note that the second term is independent of the delivered power and is a fixed function of the drive power.

Finally, the loop time constant for these parameters, using an illustrative value of 2 nF for the filter capacitor C_{FLT} , evaluates to

$$\begin{aligned} T_O &= (V_{GSC}/V_{SLP})T \\ &= (1/0.44) \times 3.07 \mu s \times 2(nF) = 13.95 \mu s \end{aligned} \quad (17)$$

Practical Loop

At the present time, power amplifiers, or VGAs preceding such amplifiers, do not provide an exponential gain characteristic. It follows that the loop dynamics (the effective time constant) will vary with the setpoint, since the exponential function is unique in providing constant dynamics. The procedure must therefore be as follows. Beginning with the curve usually provided for the power output versus APC voltage, draw a tangent at the point on this curve where the slope is highest (see Figure 5). Using this line, calculate the effective minimum value of the variable V_{GSC} , and use it in Equation 17 to determine the time constant. (Note that the minimum in V_{GSC} corresponds to the maximum rate of change in the output power versus V_{OUT} .)

For example, suppose it is found that, for a given drive power, the amplifier generates an output power of P_1 at $V_{OUT} = V_1$, and P_2 at $V_{OUT} = V_2$. Then, it is readily shown that

$$V_{GSC} = 20(V_2 - V_1)/(P_2 - P_1) \quad (18)$$

This should be used to calculate the filter capacitance. The response time at high and low power levels (on the “shoulders” of the curve shown in Figure 5) will be slower. Note also that it is sometimes useful to add a zero in the closed-loop response by placing a resistor in series with C_{FLT} .

A Note About Power Equivalency

Users of the AD8316 must understand that log amps fundamentally do not respond to power. For this reason, dBV (decibels above 1 V rms) are included in addition to the commonly used metric dBm. The dBV scaling is fixed, independent of termination impedance, while the corresponding power level

is not. For example, 224 mV rms is always -13 dBV, with one further condition of an assumed sinusoidal waveform; see the AD640 data sheet for more information about the effect of waveform on logarithmic intercept. This corresponds to a power of 0 dBm when the net impedance at the input is 50 Ω . When this impedance is altered to 200 Ω , however, the same voltage corresponds to a power level that is four times smaller ($P = V^2/R$), or -6 dBm. A dBV level may be converted to dBm in the special case of a 50 Ω system and a sinusoidal signal simply by adding 13 dB. 0 dBV is then, and only then, equivalent to 13 dBm.

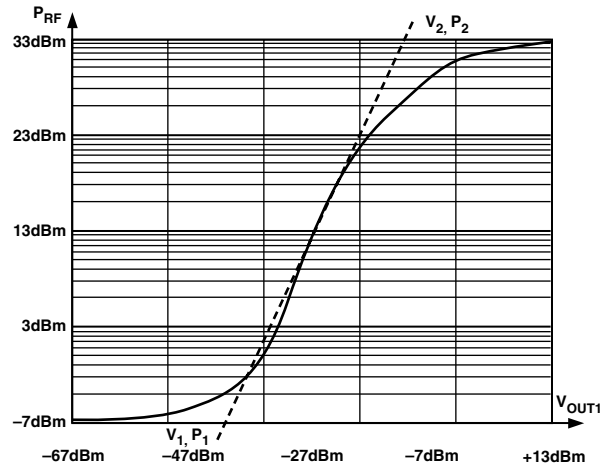

Figure 5. Typical Power Control Curve

Therefore, the external termination added ahead of the AD8316 determines the effective power scaling. This often takes the form of a simple resistor (52.3 Ω will provide a net 50 Ω input), but more elaborate matching networks may be used. The choice of impedance determines the logarithmic intercept, that is, the input power for which the V_{SET} versus P_{IN} function would cross the baseline if that relationship were continuous for all values of V_{IN} . This is never the case for a practical log amp; the intercept (so many dBV) refers to the value obtained by the minimum-error straight-line fit to the actual graph of V_{SET} versus P_{IN} (more generally, V_{IN}). Where the modulation is complex, as in CDMA, the calibration of the power response needs to be adjusted; the intercept will remain stable for any given arbitrary waveform. When a true power (waveform independent) response is needed, a mean-responding detector, such as the AD8361, should be considered.

The logarithmic slope, V_{SLP} in Equation 1, which is the amount by which the setpoint voltage needs to be changed for each decade of input change (voltage or power) is, in principle, independent of waveform or termination impedance. In practice, it usually falls off somewhat at higher frequencies, because of the declining gain of the amplifier stages and other effects in the detector cells (see TPC 13).

Basic Connections

Figure 6 shows the basic connections for operating the AD8316 and Figure 7 shows a block diagram of a typical application. The AD8316 is typically used in the RF power control loop of dual mode and trimode mobile handsets where there is more than one RF power control line.

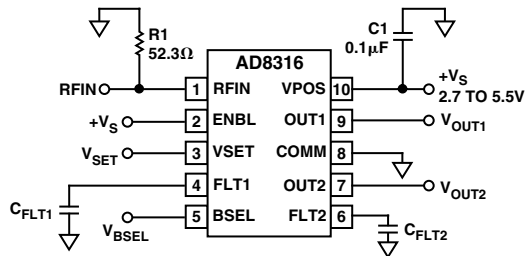

Figure 6. Basic Connections (Shown with MSOP Pinout)

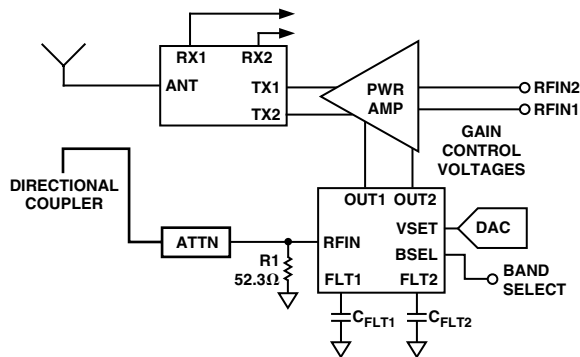

Figure 7. Block Diagram of Typical Application

A supply voltage of 2.7 V to 5.5 V is required for the AD8316. The supply to the VPOS pin should be decoupled with a low inductance 0.1 μ F surface-mount ceramic capacitor close to the device. The AD8316 has an internal input coupling capacitor, which negates the need for external ac coupling. This capacitor, along with the device's low frequency input impedance of approximately 3.0 k Ω , sets the minimum usable input frequency to around 20 MHz. A broadband 50 Ω input match is achieved in this example by connecting a 52.3 Ω resistor between RFIN and ground (COMM). A plot of input impedance versus frequency is shown TPC 9. Other matching methods are also possible (see the Input Coupling Options section).

In a power control loop, the AD8316 provides both the detector and controller functions.

A number of options exist for coupling the RF signal from the power amplifiers (PA) to the AD8316 input. Because only one PA output is active at any time, a single RF input on the AD8316 is sufficient in all cases.

Two directional couplers can be used directly at the PA outputs. The outputs of these couplers would be passively combined before being applied to the AD8316 RF input (in general, some additional attenuation will be required between the coupler and the AD8316). Another option involves using a dual-directional coupler between the PA and T/R switch. This device has two inputs/outputs and a single-coupled output so that no external combiner is required.

A third option is to use a single broadband directional coupler at the output of the transmit/receive (T/R) switch (the outputs from the two PAs are combined in the T/R switch). This is shown in Figure 7. This provides the advantage of enabling the power at the output of the T/R switch to be precisely set, eliminating any errors due to insertion loss and insertion loss variations of the T/R switch.

A setpoint voltage is applied to VSET from the controlling source, generally a DAC. Any imbalance between the RF input

level and the level corresponding to the setpoint voltage will be corrected by the selected output, OUT1 or OUT2, which drives the gain control terminal of the PAs. This restores a balance between the actual power level sensed at the input of the AD8316 and the demanded value determined by the setpoint. This assumes that the gain control sense of the variable gain element is positive; that is, an increasing voltage from OUT1 or OUT2 will tend to increase gain. The outputs can swing from 100 mV above ground to within 100 mV of the supply rail and can source up to 12 mA. (A plot of maximum output voltage versus output current is shown in TPC 19.) OUT1/OUT2 are capable of sinking more than 200 μ A.

Range on VSET and RF Input

The relationship between RF input level and the setpoint voltage follows from the nominal transfer function of the device (see TPCs 2, 3, 5, and 6). At 0.9 GHz, for example, a voltage of 1 V on VSET indicates a demand for -17 dBm (-30 dBV) at RFIN. The corresponding power level at the output of the power amplifier will be greater than this amount due to the attenuation through the directional coupler. For setpoint voltages of less than approximately 200 mV and RF input amplitudes greater than approximately -50 dBm, V_{OUT} will remain unconditionally at its minimum level of approximately 250 mV. This feature can be used to prevent any spurious emissions during power-up and power-down phases. Above 250 mV, VSET will have a linear control range up to 1.4 V, corresponding to a dynamic range of 49 dB. This results in a slope of 22.2 mV/dB or approximately 45.5 dB/V.

Transient Response

The time domain response of power amplifier control loops, using any kind of controller, is only partially determined by the choice of filter which, in the case of the AD8316, has a true integrator form $1/sT$, as shown in Equation 7, with a time constant given by Equation 8. The large signal step response is also strongly dependent on the form of the gain control law. Nevertheless, some simple rules can be applied. When the filter capacitor C_{FLT} is very large, it will dominate the time domain response, but the incremental bandwidth of this loop will still vary as V_{OUT} traverses the nonlinear gain control function of the PA, as shown in Figure 5. This bandwidth will be highest at the point where the slope of the tangent drawn on this curve is greatest—that is, for power outputs near the center of the PA's range—and will be much reduced at both the minimum and the maximum power levels, where the slope of the gain control curve is lowest, due to its S-shaped form. Using smaller values of C_{FLT} , the loop bandwidth will generally increase, in inverse proportion to its value. Eventually, however, a secondary effect will appear, due to the inherent phase lag in the power amplifier's control path, some of which may be due to parasitic or deliberately added capacitance at the OUT1 and OUT2 pins. This results in the characteristic poles in the ac loop equation moving off the real axis and thus becoming complex (and somewhat resonant). This is a classic aspect of control loop design.

The lowest permissible value of C_{FLT} needs to be determined experimentally for a particular amplifier and circuit board layout. For GSM and DCS power amplifiers, C_{FLT} will typically range from 150 pF to 300 pF.

In many cases, some improvement in the worst-case response time can be achieved by including a small resistance in series with C_{FLT} ; this generates an additional zero in the closed-loop transfer function, which will serve to cancel some of the higher-order

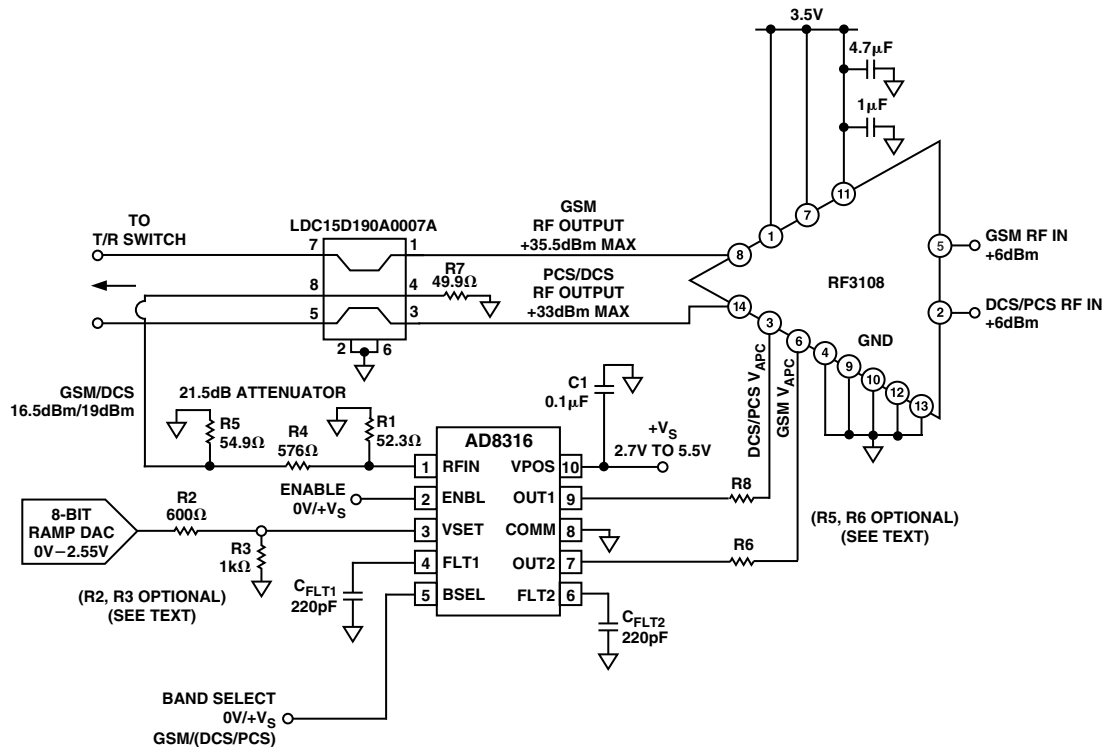

Figure 8. Dual-Mode (GSM/DCS) PA Control Example (Shown with AD8316 MSOP Pinout)

poles in the overall loop. A combination of main capacitor C_{FLT} shunted by a second capacitor and resistor in series will also be useful in minimizing the settling time of the loop.

Mobile Handset Power Control Example

Figure 8 shows a complete power amplifier control circuit for a dual-mode handset. The RF3108 (RF Micro Devices), dual-input, trimode (GSM, DCS, PCS) PA is driven by a nominal power level of 6 dBm at both inputs and has two gain control lines. Some of the output power from the PA is coupled off using a dual-band directional coupler (Murata part number LDC15D190A0007A). This has a coupling factor of approximately 20 dB for the GSM band and 15 dB for DCS and an insertion loss of 0.38 dB and 0.45 dB, respectively. Because the RF3108 transmits a maximum power level of approximately 35 dBm for GSM and 32 dBm for DCS/PCS, additional attenuation of 20 dB is required before the coupled signal is applied to the AD8316. This results in peak input levels of -5 dBm (GSM) and -3 dBm (DCS). While the AD8316 gives a linear response for input levels up to $+3$ dBm, for highly temperature-stable performance at maximum PA output power, the maximum input level should be limited to approximately -3 dBm (see TPC 3 and TPC 5). This does, however, reduce the sensitivity of the circuit at the low end.

The operational setpoint voltage, in the range 250 mV to 1.4 V, is applied to the VSET pin of the AD8316. This will typically be supplied by a DAC. The desired output is selected by applying a high or low signal to the BSEL pin (HI = OUT1, LO = OUT2). The selected output directly drives the level control pin of the power amplifier. In this case a minimum supply voltage of 2.9 V is required and V_{OUT} reaches a maximum value of approximately 2.6 V while delivering about 5 mA to the PA's V_{APC} input. For power amplifiers with lower V_{APC} input ranges, a corresponding low power supply to the AD8316 can be used. For example, on

a 2.7 V supply, the voltage on OUT1/OUT2 can come to within approximately 100 mV of the supply rail. This will depend, however, on the current draw (see TPC 19).

During initialization and completion of the transmit sequence, V_{OUT} should be held at its minimum level of 250 mV by keeping V_{SET} below 200 mV. In this example, V_{SET} is supplied by an 8-bit DAC that has an output range from 0 V to 2.55 V or 10 mV per bit. This sets the control resolution of V_{SET} to 0.4 dB/bit (0.04 dB/mV \times 10 mV). If finer resolution is required, the DAC's output voltage can be scaled using two resistors as shown. This converts the DAC's maximum voltage of 2.55 V down to 1.6 V and increases the control resolution to 0.25 dB/bit.

Two filter capacitors (C_{FLT1}/C_{FLT2}) must be used to stabilize the loop for each band. The choice of C_{FLT} will depend to a large degree on the gain control dynamics of the power amplifier, something that is frequently poorly characterized, so some trial and error may be necessary. In this example, a 220 pF capacitor is used. The user may want to add a resistor in series with the filter capacitor. The resistor adds a zero to the control loop and increases the phase margin, which helps to make the step response of the circuit more stable when the slope of the PA's power control function is the steepest. In this example, the two filter capacitors are equal values; however, this is not a requirement.

A smaller filter capacitor can be used by inserting a series resistor between V_{OUT} and the control input of the PA. A series resistor will work with the input impedance of the PA to create a resistor divider and will reduce the loop gain. The size of the resistor divider ratio depends upon the available output swing of V_{OUT} and the required control voltage on the PA. This technique can also be used to limit the control voltage in situations where the PA cannot deliver the power level demanded by V_{OUT} . Overdrive of the control input of some PAs causes increased distortion.

Enable and Power-On

The AD8316 may be disabled by pulling the ENBL pin to ground. This reduces the supply current from its nominal level of 8.5 mA to 3 μ A at 2.7 V. The logic threshold for turning on the device is at 1.8 V at 2.7 V. A plot of the enable glitch is shown in TPC 20. Alternatively, the device can be completely disabled by pulling the supply voltage to ground; ENBL would be connected to VPOS. The glitch in this mode of operation is shown on TPC 25 and TPC 26. If VPOS is applied before the device is enabled, a narrow glitch of less than 50 mV will result. This is shown in TPC 31.

In both situations, the voltage on V_{SET} should be kept below 250 mV during power-on and power-off, preventing any unwanted transients on V_{OUT} .

Input Coupling Options

The internal 5 pF coupling capacitor of the AD8316, along with the low frequency input impedance of 3 k Ω , result in a high-pass input corner frequency of approximately 20 MHz. This sets the minimum operating frequency. Figure 9 shows three options for input coupling. A broadband resistive match can be implemented by connecting a shunt resistor to ground at RFIN. This 52.3 Ω resistor (other values can also be used to select different overall input impedances) combines with the input impedance of the AD8316 (3 k Ω ||1 pF) to give a broadband input impedance of 50 Ω . While the input resistance and capacitance (C_{IN} and R_{IN}) will vary by approximately $\pm 20\%$ from device to device, the dominance of the external shunt resistor means that the variation in the overall input impedance will be close to the tolerance of the external resistor. This method of matching is most useful in wideband applications or in multimode systems where there is more than one operating frequency and those frequencies are quite far apart.

A reactive match can also be implemented as shown in Figure 9b. This is not recommended at low frequencies because device tolerances will vary the quality of the match dramatically because of the large input resistance. For low frequencies, Option 9a or Option 9c is recommended.

In Figure 9b, the matching components are drawn as generic reactances. Depending on the frequency, the input impedance at that frequency, and the availability of standard value components, either a capacitor or an inductor will be used. As in the previous case, the input impedance at a particular frequency is plotted on a Smith chart and matching components are chosen (shunt or Series L, shunt or Series C) to move the impedance to the center of the chart.

Figure 9c shows a third method for coupling the input signal into the AD8316, applicable where the input signal is larger than the input range of the log amp. A series resistor, connected to the RF source, combines with the input impedance of the AD8316 to resistively divide the input signal being applied to the input. This has the advantage of very little power being tapped off in RF power transmission applications.

Using the Chip Scale Package

On the underside of the chip scale package, there is an exposed paddle. This paddle is internally connected to the chip's ground. For better electrical performance, this paddle should be soldered down to the printed circuit board's ground plane, even though there is no thermal requirement to do so.

EVALUATION BOARD

Figures 10 and 11 show the schematics of the AD8316 MSOP and LFCSP evaluation boards. Note that uninstalled components are marked as open. The layout and silkscreen of the MSOP evaluation board are shown in Figures 12 and 13. Apart from the slightly smaller device footprint and number of pins, the LFCSP evaluation board is identical to the MSOP board. The boards are powered by a single supply in the 2.7 V to 5.5 V range. The power supply is decoupled by a single 0.1 μ F capacitor. Table II details the various configuration options of the evaluation boards.

For operation in controller mode, both jumpers, LK1 and LK2, should be removed. OUT1 and OUT2 can be selected with SW3 in Position A and Position B, respectively. The setpoint voltage is applied to VSET, RFIN is connected to the RF source (PA output or directional coupler), and OUT1 or OUT2 is connected to the gain control pins of each PA. When the AD8316 is used in controller mode, a capacitor and a resistor must be installed in C4, C6, and R10, R11 for loop stability. For GSM/DCS handset power amplifiers, this capacitor should typically range from 150 pF to 300 pF. The series resistor improves the system phase margin at low power levels, which in turn improves the step response in the circuit. Typically, this resistor value should be about 1.5 k Ω .

A quasi-measurement mode (in which the AD8316 delivers an output voltage that is proportional to the log of the input signal) can be implemented to establish the relationship between V_{SET} and RF_{IN} with the installation of two jumpers, LK1 and LK2. This mimics an AGC loop. To establish the transfer function of the log amp, the RF input should be swept while the voltage on VSET is measured, that is, the SMA connector labeled VSET acts as an output. This is the simplest method for validating operation of the evaluation board. When operated in this mode, a large capacitor (0.01 μ F or greater) must be installed in C4 or C6 (set R10/R11 to 0 Ω) to ensure loop stability.

AD8316

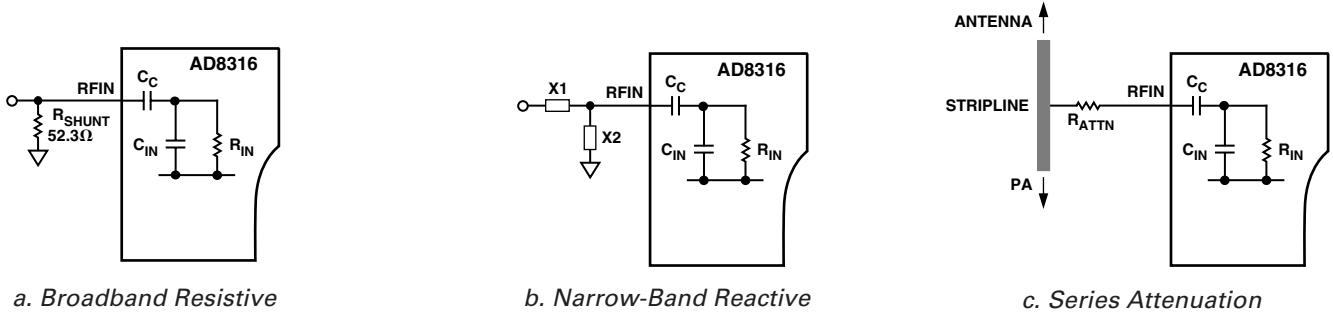

Figure 9. Input Coupling Options

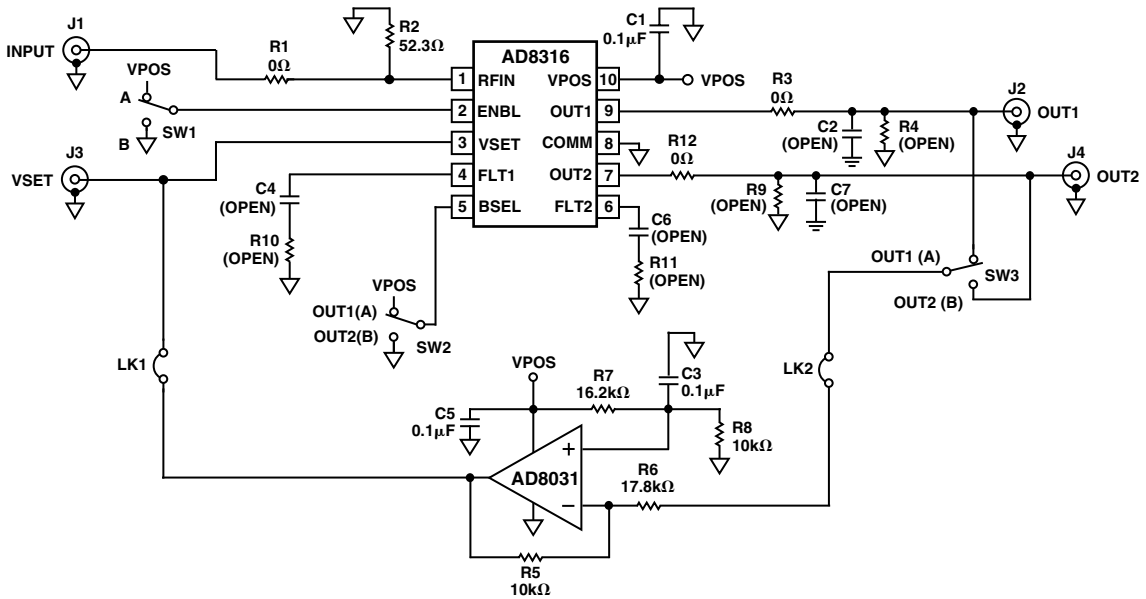

Figure 10. Schematic of Evaluation Board (MSOP)

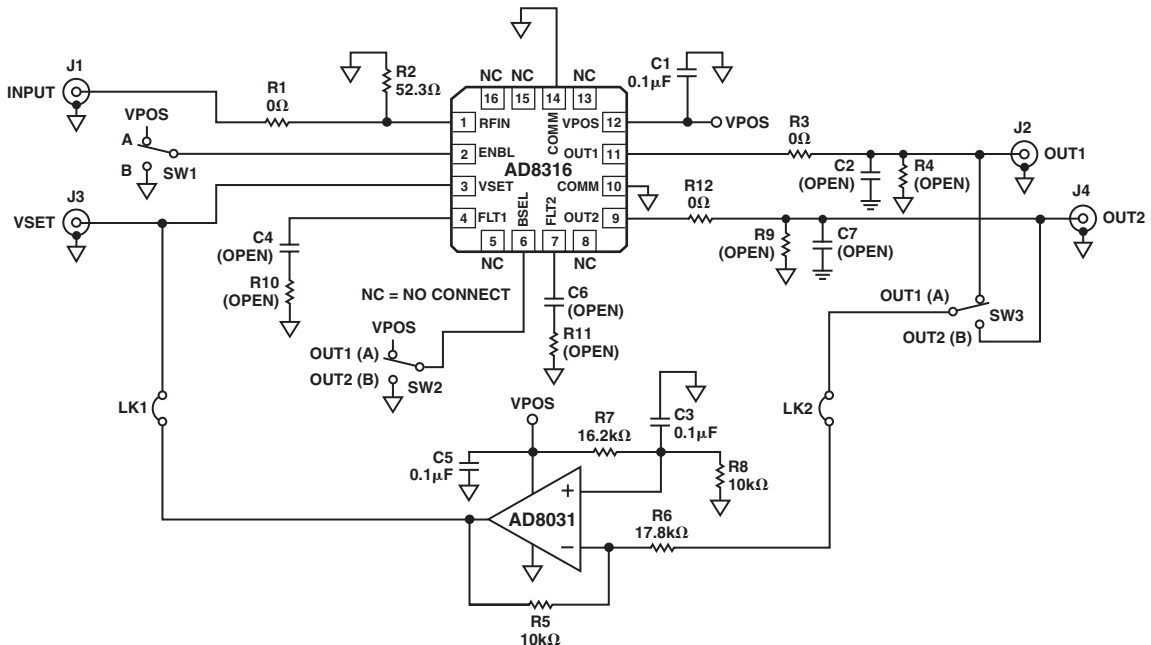

Figure 11. Schematic of Evaluation Board (LFCSP)

Table II. Evaluation Board Configuration Options

Component	Function	Default Condition
TP1, TP2	Supply and Ground Vector Pins.	Not Applicable
SW1	Device Enable. When in Position A, the ENBL pin is connected to VPOS and the AD8316 is in operating mode. In Position B, the ENBL pin is grounded, putting the device into power-down mode.	SW1 = A
SW2	Band Select. When in Position A (OUT1), the BSEL pin is connected to VPOS and the AD8316 OUT1 is in operation mode. In Position B (OUT2), the BSEL pin is grounded and the AD8316 OUT2 is in operation while OUT1 pin is shut down.	SW2 = OUT1
R1, R2	Input Interface. The 52.3 Ω resistor in Position R2 combines with the AD8316's internal input impedance to provide a broadband input impedance of around 50 Ω . A reactive match can be implemented by replacing R2 with an inductor and R1 (0 Ω) with a capacitor. In addition, the RF microstrip line has been provided with a clean mask ground plane to provide additional matching. Note that the AD8316's RF input is internally ac-coupled.	R2 = 52.3 Ω (Size 0603) R1 = 0 Ω (Size 0402)
R3, R4, R12, R9, C2, C7	Output Interface. R4 and C2, R9 and C7 can be used to check the response capacitive and resistive loading, respectively. R3/R4 and R12/R9 can be used to reduce the slope of OUT1 and OUT2.	R4 = C2 = Open (Size 0603) R9 = C7 = Open (Size 0603) R3 = R12 = 0 Ω (Size 0603)
C1, C5	Power Supply Decoupling. The nominal supply decoupling consists of a 0.1 μ F capacitor.	C1 = C5 = 0.1 μ F (Size 0603)
C4, C6, R10, R11	Filter Capacitors/Resistors. The response time of OUT1, OUT2 can be modified by placing the capacitors between FLT1, FLT2 and resistors R10, R11 to ground.	C4 = C6 = Open (Size 0603) R10 = R11 = Open (Size 0603)
LK1, LK2	Measurement Mode. A quasi-measurement mode can be implemented by installing LK1 and LK2 (connecting an inverted OUT1 or OUT2 to VSET) to yield the nominal relationship between RFIN and VSET. In this mode, a large capacitor (0.01 μ F or greater) must be installed in C4 and C6 and a 0 Ω resistors to ground in R10 and R11. To select OUT1 or OUT2, SW3 must be in the OUT1 position or the OUT2 position, respectively.	LK1, LK2 = Installed
SW3	Measurement Mode Output Select. When in measurement mode, output 1 or output 2 can be selected by positioning SW3 to the OUT1 position or the OUT2 position, respectively.	SW3 = OUT1

AD8316

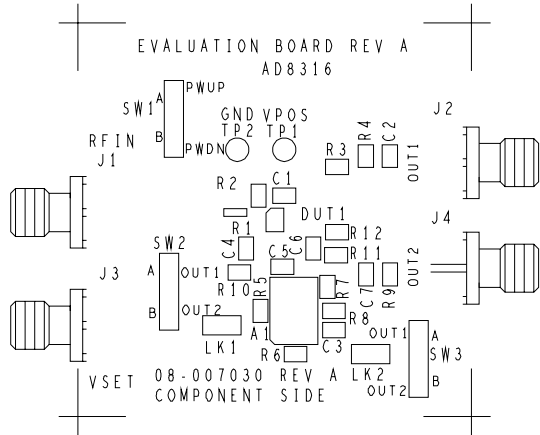

Figure 12. Silkscreen of Component Side (MSOP)

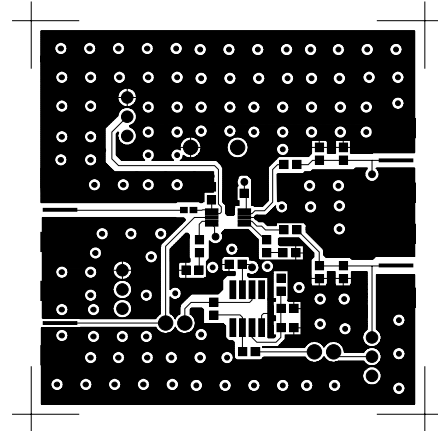

Figure 13. Layout of Component Side (MSOP)

AD8316

Revision History

Location	Page
1/04–Data Sheet changed from REV. B to REV. C.	
Changes to FEATURES	1
12/03–Data Sheet changed from REV. A to REV. B.	
Updated ORDERING GUIDE	3
Edit to Figure 8	14
Updated OUTLINE DIMENSIONS	19
3/03–Data Sheet changed from REV. 0 to REV. A.	
Addition of LFCSP package	Universal
Edits to SPECIFICATIONS	2
Edits to ABSOLUTE MAXIMUM RATINGS	3
Edits to ORDERING GUIDE	3
Edits to TPC 4	4
TPC 9 replaced	5
Edit to TPC 30	8
Edits to Example section	11
Edits to Input Coupling Options section	15
Addition of new Figure 11	16
Updated OUTLINE DIMENSIONS	19

C02192-0-1/04(C)