

8

7

6

5

4

3

2

1

VICOR CONFIDENTIAL

THIS DOCUMENT AND THE DATA DISCLOSED HEREIN OR HEREWITH IS NOT TO BE REPRODUCED, USED OR DISCLOSED IN WHOLE OR IN PART TO ANYONE WITHOUT THE PERMISSION OF VICOR CORP.

REVISIONS

REV	DESCRIPTION	DATE	APPROVED
1	RELEASED PER E060499	02/16/06	PEI MB
2	REVISED PER E063650	03/13/06	PEI MB
3	REVISED PER E060905	07/28/06	BW MB
4	REVISED PER E072040	09/06/07	JS SG
5	REVISED PER E091875	10/20/09	JS REJH
6	REVISED PER E092163	12/04/09	GCK MH
7	REVISED PER E101309	10/22/10	KUK AR

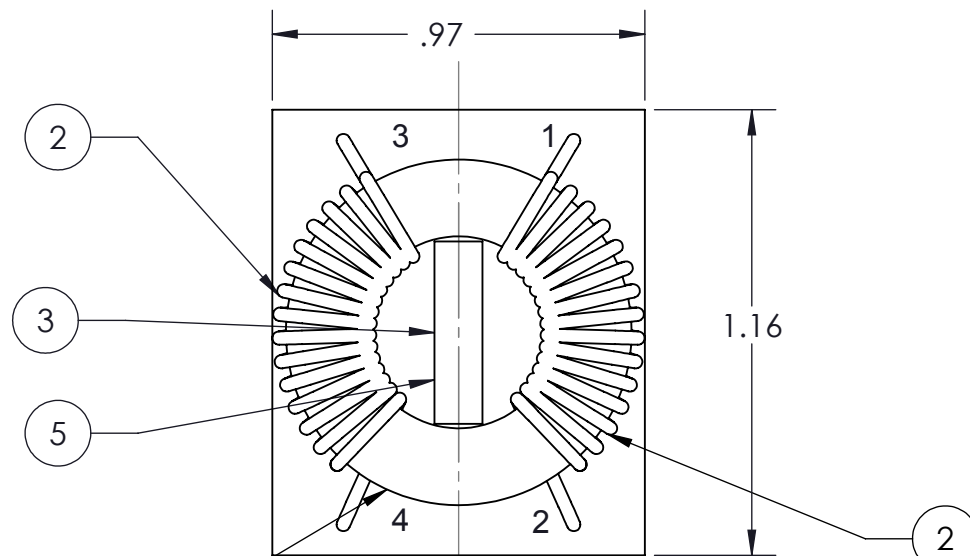

REF: ISOLATION INSULATOR (FR4) SEE NOTES 5 & 7

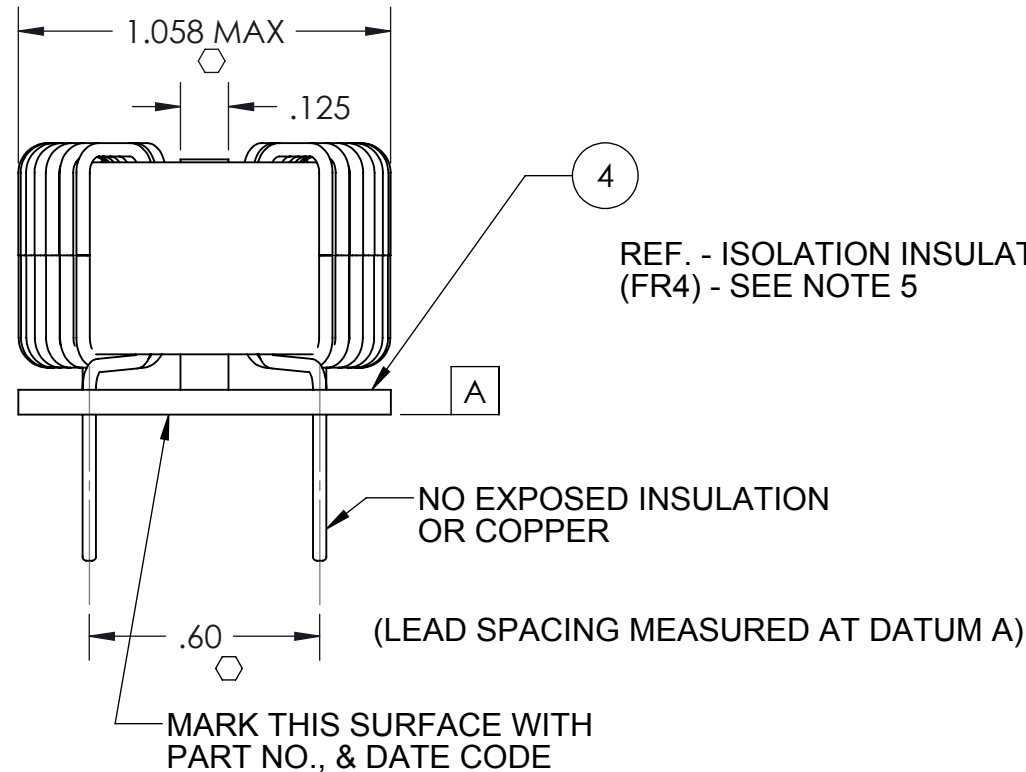
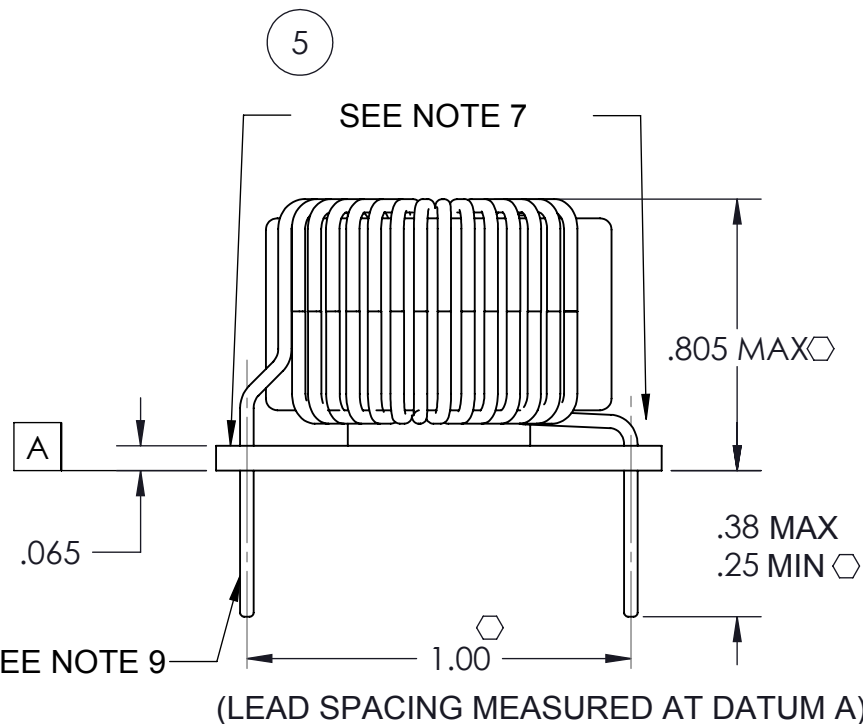

REF. - ISOLATION INSULATOR (FR4) - SEE NOTE 5

NO EXPOSED INSULATION OR COPPER

(LEAD SPACING MEASURED AT DATUM A)

MARK THIS SURFACE WITH PART NO., & DATE CODE

WIRE GAUGE TABLE

PN#	WIRE GAUGE	PIN DIAMETER AFTER TINNING (+/- .003")
31741	#21	0.030"
31742	#19	0.036"
31743	#16	0.051"
31744	#16	0.051"

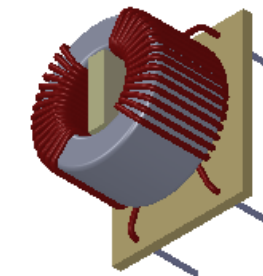

- NOTES:
1. ASSEMBLY TO BE FREE OF NICKS.
 2. WINDINGS TO BE EVENLY SPACED.
 3. RoHS COMPLIANT. LEAD FREE PER CST-0001 LATEST REVISION.
 4. GENERAL WORKMANSHIP STANDARDS FOR MAGNETIC COMPONENTS PER WS-0002.
 5. ITEMS 3 & 4 SUPPLIED BY VENDOR AT ASSEMBLY.
 6. ALL PARTS FLAME RATED MIN U.L. 94V-0.
 7. APPLY ADHESIVE (ITEM 5) TO THE BASE OF ISOLATION INSULATOR (ITEM 3) AND TO ALL LEADS ON THE TOP SURFACE OF THE BOARD.
 8. □ DENOTES CRITICAL CHARACTERISTIC FOR LOT INSPECTION.
 9. SEE TABLE FOR WIRE GAUGE DIMENSIONS.
 10. LEADS MAY BE TINNED WITH SN96/AG4 OR SAC305 (SN 96.5, AG 3.0, CU 0.5) OR VICOR APPROVED EQUIVALENT.
 11. DIMENSIONS ARE INCHES ONLY.

DRAWN	DATE
P.E.IENI	11/02/05

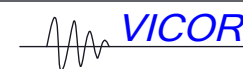

SWD

MATERIAL	UNLESS OTHERWISE SPECIFIED DIMENSIONS ARE INCH [MM] TOLERANCES ARE: DECIMALS ANGLES X.XX [X.X] = ±0.01 [0.25] ±1° X.XXX [X.XX] = ±0.005 [0.127]
SEE NOTES	
FINISH	THIRD ANGLE PROJECTION
SEE NOTES	DO NOT SCALE DRAWING

IND TOR 1.03 DIA 2W ASSY DWG

SIZE	CAGE CODE	DWG NO	REV
B	67131	31895	7
SCALE 2 : 1		SHEET 1 OF 1	

8

7

6

5

4

3

2

1