

THIS DRAWING IS UNPUBLISHED. RELEASED FOR PUBLICATION  
 © COPYRIGHT - By - ALL RIGHTS RESERVED.

LOC	DIST	REVISIONS			
P	LTR	DESCRIPTION	DATE	DWN	APVD
GP	00	J	REVISED PER ECO-12-021696	28FEB2013	CJV CWR

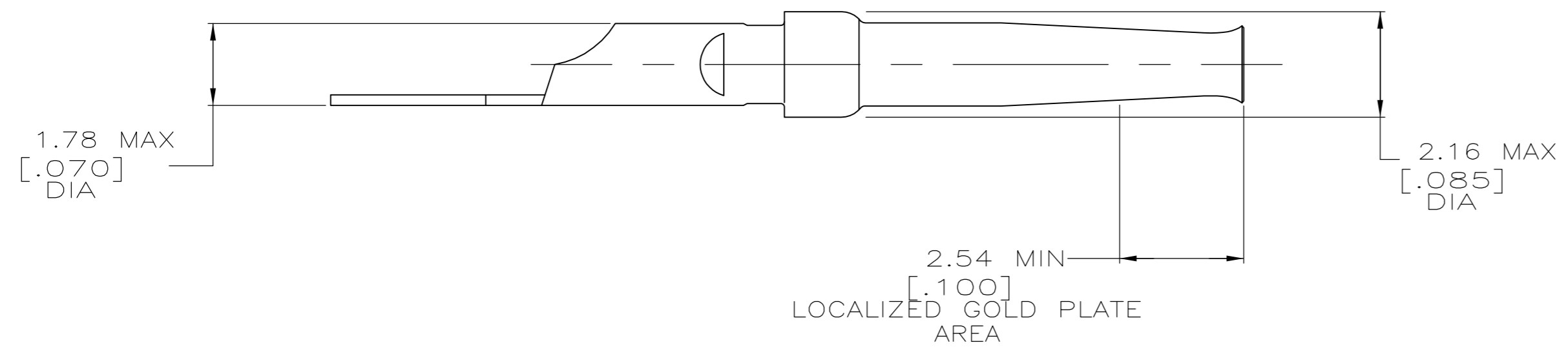
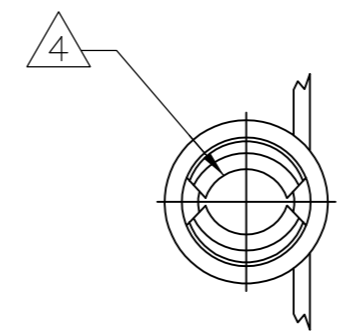
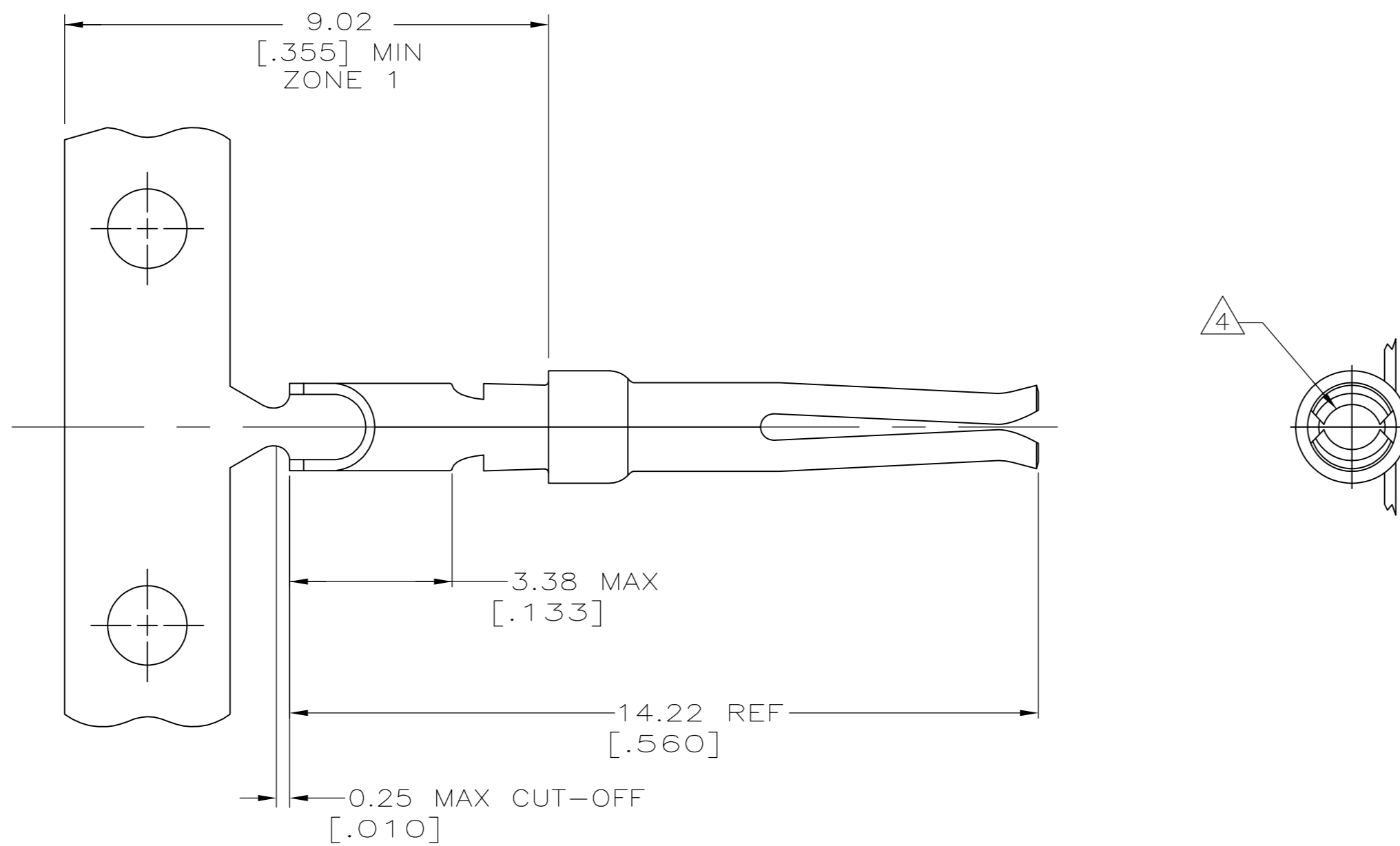

- ① PHOSPHOR BRONZE PER QQ-B-750.
- ② GOLD PLATED AREA AS FOLLOWS: PLATED WITH 0.76µm [.000030] GOLD IN LOCALIZED GOLD PLATE AREA, .000100 MIN MATTE TIN IN ZONE 1, OVER 1.27µm [.000050] MIN NICKEL. OR GOLD FLASH OVER PALLADIUM-NICKEL PLATE, 0.76µm [.000030] MIN TOTAL IN LOCALIZED GOLD PLATE AREA, .000100 MIN MATTE TIN IN ZONE 1, OVER 1.27µm [.000050] MIN NICKEL.
- ③ GOLD PLATING PER MIL-G-45204, NICKEL PLATING PER QQ-N-290.
- ④ WILL ACCEPT 1.02 [.040] DIA PIN.
- 5. 1.17 [.046] MAX DIA CONDUCTOR (UP TO 18 AWG).

PACKAGING	TYPE	PART NUMBER
SMALL PACK STANDARD	LOOSE PIECE	1-66569-0
-	LOOSE PIECE	66569-3
-	STRIP	66569-2

THIS DRAWING IS A CONTROLLED DOCUMENT. DIMENSIONING AND TOLERANCING PER ASME Y14.5M-2009		DWN D.HARDY 08 NOV 95	<b>STE</b> TE Connectivity	
DIMENSIONS: mm [INCHES]		CHK R.STONE 14 NOV 95		
TOLERANCES UNLESS OTHERWISE SPECIFIED:		APVD C.STINSON 06 DEC 95	NAME	
0 PLC ± -		PRODUCT SPEC	SOCKET CONTACT, SIZE 20 DF, WITH SOLDER CUP, AMPLIMITE	
1 PLC ± -		APPLICATION SPEC	SIZE A2	CAGE CODE 00779
2 PLC ± -		WEIGHT -	DRAWING NO C-66569	RESTRICTED TO -
3 PLC ± -		CUSTOMER DRAWING		
4 PLC ± -		SCALE 10:1	SHEET 1 of 1	REV J
ANGLES ± -				
FINISH				

66569