

- NOTES:
- MATERIAL:
 - HOUSING: HIGH TEMPERATURE THERMAL PLASTIC, UL94V-0, COLOR: BLACK.
 - TERMINAL: COPPER ALLOY;
 - FORKLOCK: COPPER ALLOY.
 - TERMINAL PLATING :
 - CONTACT AREA:
 - (A) GOLD FLASH,
 - (B) GOLD, THICKNESS=0.76 MICRONS MINIMUM;
 - (C) GOLD, THICKNESS=0.38 MICRONS MINIMUM;
 - SOLDER AREA: TIN, THICKNESS=1.27 MICRONS MINIMUM;
 - UNDER PLATE: NICKEL, THICKNESS=1.27 MICRONS MINIMUM.
 - FORKLOCK PLATING:
 - SOLDER AREA: TIN, THICKNESS=1.27 MICRONS MINIMUM;
 - UNDER PLATE: NICKEL, THICKNESS=1.27 MICRONS MINIMUM.
 - PRODUCT SPECIFICATION: REFER TO PS-67492-001.
 - PACKAGING METHOD: TAPE REEL, DETAIL REFER TO PK-67492-006.
 - MATING PARTS: 87703/87672.

P/N	PLATING	REMARK
67492-1930	NOTES 2 (A)	WITH CAP
67492-1931	NOTES 2 (B)	
67492-1932	NOTES 2 (C)	WITHOUT CAP
67492-1920	NOTES 2 (A)	
67492-1921	NOTES 2 (B)	
67492-1922	NOTES 2 (C)	

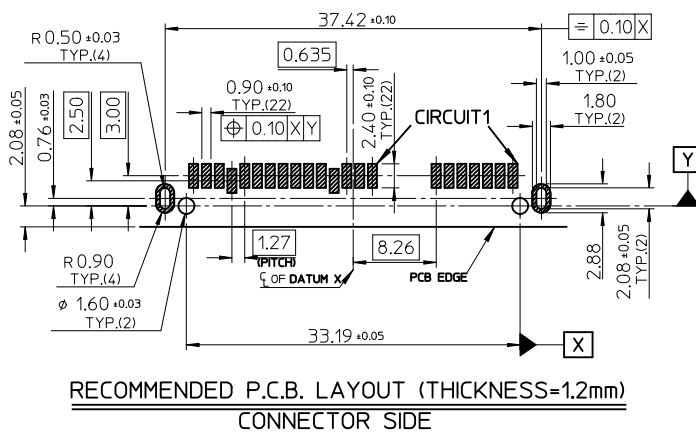
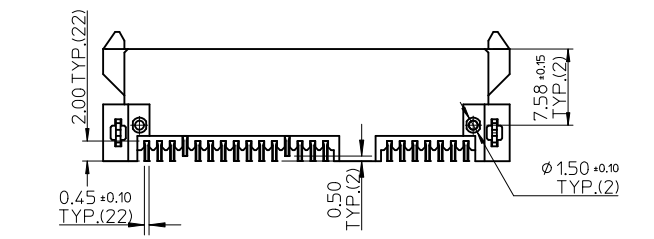

REVISED	EC NO: SH2011-0354	DRAWING: 2011/05/27	CHKD:	APPR: X JSONG	DESCRIPTION	QUALITY SYMBOLS	GENERAL TOLERANCES (UNLESS SPECIFIED)		DIMENSION STYLE		SCALE	DESIGN UNITS	THIRD ANGLE PROJECTION
							mm	INCH	MM ONLY	2:1	METRIC		
						▽ F=0	4 PLACES ± --- ± ---	DRAWN BY DIXON LI	DATE 2006/02/08	TITLE	SATA HOST RECEPTACLE R/A SMT TYPE -LEAD FREE-		
						▽ F=0	3 PLACES ± --- ± ---	CHECKED BY JENNY ZENG	DATE 2006/02/08	MOLEX MOLEX INCORPORATED			
						▽ F=0	2 PLACES ± 0.15 ± ---	APPROVED BY GRATE MA	DATE 2006/02/08				
							1 PLACE ± 0.25 ± ---	MATERIAL NO.	DOCUMENT NO.	SD-67492-010		SHEET NO. 1 OF 1	
							ANGULAR ± 3 °	SEE TABLE		THIS DRAWING CONTAINS INFORMATION THAT IS PROPRIETARY TO MOLEX INCORPORATED AND SHOULD NOT BE USED WITHOUT WRITTEN PERMISSION			
							DRAFT WHERE APPLICABLE MUST REMAIN WITHIN DIMENSIONS						