

1/32W, 01005, Thick Film Chip Resistor (Lead / Halogen Free)

1. Scope

This specification applies to 0.2mm x 0.4mm (01005) size, fixed metal film chip resistors rectangular type for use in electronic equipment.

2. Type Designation

PFR02S — XXX — X NH  
(1) (2) (3) (4)

Where (1) Series No

(2) Nominal resistance value:

For example –

Three digits of number (E-24 Series)

000 = Jumper

100 = 10Ω

102 = 1kΩ

Four digits of number (E-96 Series)

11R3 = 11.3Ω

1131 = 1.13kΩ

(3) Tolerance of Resistance

F = ± 1.0%

G = ± 2.0%

J = ± 5.0%

X = Jumper ( Below 50 mΩ )

(4) NH = Sn plating ( Lead free / Halogen free)

3. Electrical Specifications

Table 1

*Power rating	1/32W					
Resistance Values	E-24 series , E-96 series			E-24 series		
Resistance Tolerance	± 1.0%(F)			± 5.0%(J)	± 2.0%(G) , ± 5.0%(J)	
Resistance Range ( Ω )	1.0 ~ 9.76	10 ~ 91	100 ~ 1.62M	1.0 ~ 9.1	10 ~ 91	100 ~ 10M
Temperature Coefficient of Resistance(ppm/°C)	+600 ~ -200	± 300	± 200	+600 ~ -200	± 300	± 200
Operating temperature range	- 55°C to + 125°C					
Max. operating voltage**	15V					

Note:\*Package Power Temperature Derating Curve

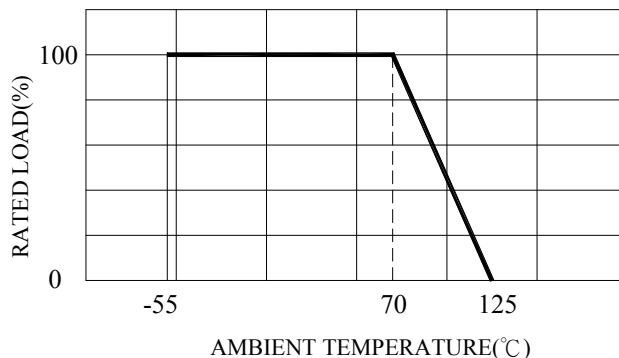

Figure 1. : Power Temperature Derating Curve

Note: \*\*Resistors shall have a rated DC or AC(rms.) continuous operating voltage corresponding to the power rating, as calculated from the following formula

$$V = \sqrt{P \times R}$$

Where V : Rated voltage (V)

P : Rated power (W)

R : Nominal resistance (Ω)

If the voltage so obtained exceeds the maximum operating voltage, this maximum voltage shall be the rated voltage.

Table 2. : Jumper:

Resistance Tolerance	Below 50 mΩ
Rated current	0.5A
Operating Temperature Range	-55°C to 125 °C

4. Construction and Physical Dimension

4-1.

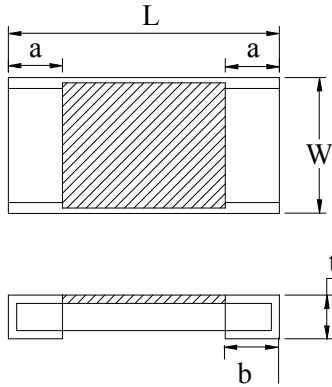

Code Letter	Dimension
L	0.40 ± 0.02
W	0.20 ± 0.02
t	0.13 ± 0.02
a	0.10 ± 0.03
b	0.10 ± 0.03

Unit: mm

4-2. just 1.0Ω~9.76Ω 1.0%(F)

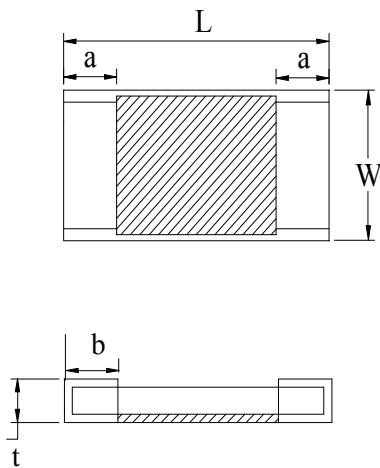

Which resistance layer (protection coating layer) is down

5. Marking

No marking on the protect coating

6. Life Tests

6-1 Electrical

Item	Specification and Requirement		Test Method (Refer to JIS C 5201)
	Resistor	Jumper	
Short Time Overload	$\Delta R: \pm (2\% + 0.1\Omega)$ Without damage by flashover, spark, arcing, burning or breakdown	Max. 50m $\Omega$	(1) Applied voltage: 2.5 x rated voltage or 2 x Maximum operating voltage which ever is less (2) Test time : 5 seconds
Insulation Resistance	Over 100 M $\Omega$ on Overcoat layer face up Over 1,000 M $\Omega$ on Substrate side face up		(1) Setup as figure 2 (2) Test voltage: 50 V <sub>DC</sub> (3) Test time: 60 + 10 / -0 seconds
Voltage Proof	$\Delta R: \pm (2\% + 0.1\Omega)$ Without damage by flashover, spark, arcing, burning or breakdown	Max. 50m $\Omega$	(1) Setup as figure 2 (2) Test voltage: 50 V <sub>AC</sub> (rms.) (3) Test time: 60 + 10 / -0 seconds

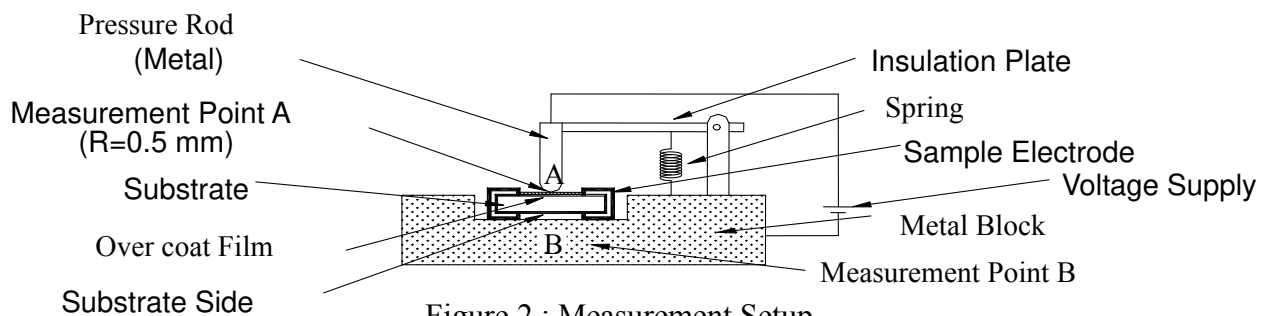

Figure 2 : Measurement Setup

6-2 Mechanical

Item	Specification and Requirement		Test Method (Refer to JIS C 5201)
	Resistor	Jumper	
Solderability	The surface of terminal immersed shall be minimum of 95% covered with a new coating of solder		Solder bath: After immersing in flux, dip in $245 \pm 5^{\circ}\text{C}$ molten solder bath for $2 \pm 0.5$ seconds
Resistance to Solder Heat	$\Delta R: \pm (1.0\% + 0.05\Omega)$ Without distinct deformation in appearance	Max. $50\text{m}\Omega$	(1) Immersed at solder bath of $270 \pm 5^{\circ}\text{C}$ for $10 \pm 1$ seconds (2) Measuring resistance 1 hour after test
Vibration	$\Delta R: \pm (0.5\% + 0.05\Omega)$ Without mechanical damage such as break		(1) Vibration frequency: 10Hz to 55Hz in 60 seconds as a period (2) Vibration time: period cycled for 2 hours in each of 3 mutual perpendicular directions (3) Amplitude: 1.5mm
Shock	$\Delta R: \pm (0.25\% + 0.05\Omega)$ Without mechanical damage such as break		(1) Peak value: 490N (2) Duration of pulse: 11ms (3) 3 times in each positive and negative direction of 3 mutual perpendicular directions
Bending Test	$\Delta R: \pm (1.0\% + 0.05\Omega)$ Without mechanical damage such as break		Bending value: 3 mm for $30 \pm 1$ seconds
Solvent Resistance	Without mechanical and distinct damage in appearance	Max. $50\text{m}\Omega$	(1) Solvent: Trichloroethane or Isopropyl alcohol (2) Immersed in solvent at room temperature for 90 seconds

6-3 Endurance

Item	Specification and Requirement		Test Method (Refer to JIS C 5201)
	Jumper	Jumper	
Rapid change of Temperature	$\Delta R: \pm (1.0\% + 0.05\Omega)$ Without distinct damage in appearance	Max. 50m $\Omega$	(1) Repeat 5 cycle as follow: (-55 $\pm$ 3 $^{\circ}$ C, 30minutes) →(Room temperature, 2~3 minutes) → (+125 $\pm$ 2 $^{\circ}$ C, 30minutes) →(Room temperature, 2~3 minutes) (2) Measuring resistance 1 hour after test
Moisture with Load	$\Delta R: \pm (5.0\% + 0.1\Omega)$ Without distinct damage in appearance Marking should be legible	Max. 50m $\Omega$	(1) Environment condition: 40 $\pm$ 2 $^{\circ}$ C, 90~95% RH (2) Applied Voltage: rated voltage (3) Test period: (1.5 hour ON) →(0.5 hour OFF) cycled for total 1,000 + 48 / - 0 hours (4) Measuring resistance 1 hour after test
Load Life	$\Delta R: \pm (5.0\% + 0.1\Omega)$ Without distinct damage in appearance	Max. 100m $\Omega$	(1) Test temperature: 70 $\pm$ 2 $^{\circ}$ C (2) Applied Voltage: rated Voltage (3) Test period: (1.5 hour ON) →(0.5 hour OFF) cycled for total 1,000 + 48 / - 0 hours (4) Measuring resistance 1 hour after test
Low Temperature Store	$\Delta R: \pm (5.0\% + 0.1\Omega)$ Without distinct damage in appearance	Max. 100m $\Omega$	(1) Store temperature: -55 $\pm$ 3 $^{\circ}$ C for total 1,000 + 48 / - 0 hours (2) Measuring resistance 1 hour after test
High Temperature Store	$\Delta R: \pm (5.0\% + 0.1\Omega)$ Without distinct damage in appearance	Max. 100m $\Omega$	(1) Store temperature: +125 $\pm$ 2 $^{\circ}$ C for total 1,000 + 48 / - 0 hours (2) Measuring resistance 1 hour after test

### 7. Recommend Land Pattern Dimensions

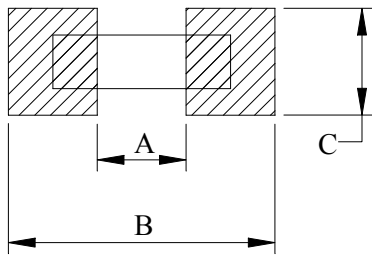

A	0.15 ~ 0.20
B	0.5 ~ 0.8
C	0.2 ~ 0.4

Unit: mm

### 8. Packaging

#### 8-1 Dimensions

##### 8-1-1 Tape packaging dimensions

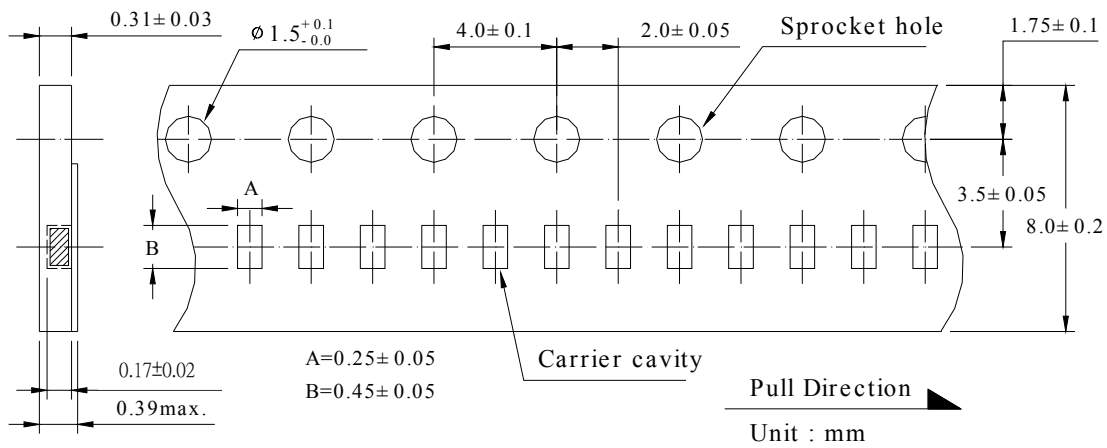

##### 8-1-2 Reel dimensions

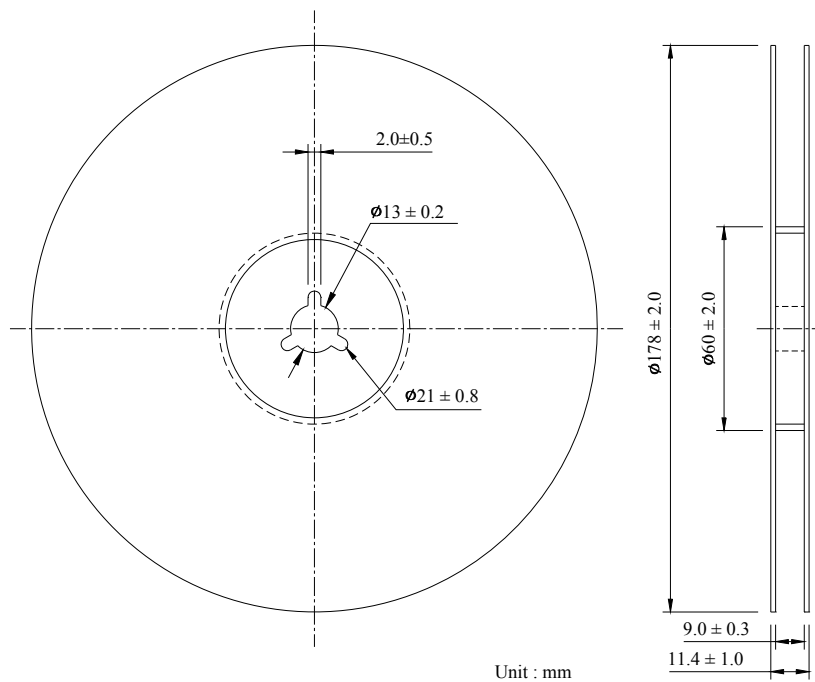

### 8-2 Peel force of top cover tape

The peel speed shall be about 300 mm/min.

The peel force of top cover tape shall be between 0.1 to 0.5 N.

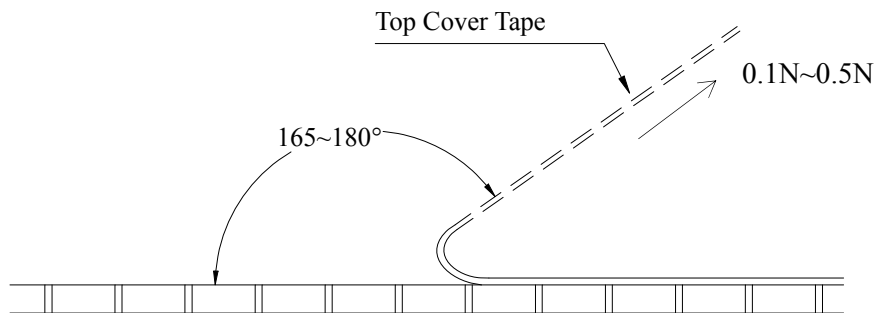

### 8-3 Numbers of taping

20,000 pieces /reel

### 8-4 Making

The following items shall be marked on the reel.

- (1) Type designation.
- (2) Quantity
- (3) Manufacturing date code
- (4) Manufacturer's name



9. Care note

9-1 Care note for storage

- (1) Chip resistor shall be stored in a room where temperature and humidity must be controlled. (temperature 5 to 35°C, humidity 45 to 85% RH) However, a humidity keep it low, as it is possible.
- (2) Chip resistor shall be stored as direct sunshine doesn't hit on it.
- (3) Chip resistor shall be stored with no moisture, dust, a material that will make solderability inferior, and a harmful gas (Chloridation hydrogen, sulfurous acid gas, and sulfuration hydrogen)

9-2 Care note for operating and handling

- (1) It is necessary to protect the edge and protection coat of resistors from mechanical stress.
- (2) Handle with care when printing circuit board (PCB) is divided or fixed on support body, because bending of printing circuit board (PCB) mounting will make mechanical stress for resistors.
- (3) Resistors shall be used with in rated range shown in specification. Especially, if voltage more than specified value will be loaded to resistor, there is a case it will make damage for machine because of temperature rise depending on generating of heat, and increase resistance value or breaks.
- (4) In case that resistor is loaded a rated voltage, it is necessary to confirms temperature of a resistor and to reduce a load power according to load reduction curve, because a temperature rise of a resistor depends on influence of heat from mounting density and neighboring element.
- (5) Observe Limiting element voltage and maximum overload voltage specified in each specification
- (6) If there is possibility that a large voltage (pulse voltage, shock voltage) charge to resistor, it is necessary that operating condition shall be set up before use.