

2 BAY STAC64 RIGHT ANGLE HEADER ASSEMBLY (P/N: 34708-2012 SHOWN)

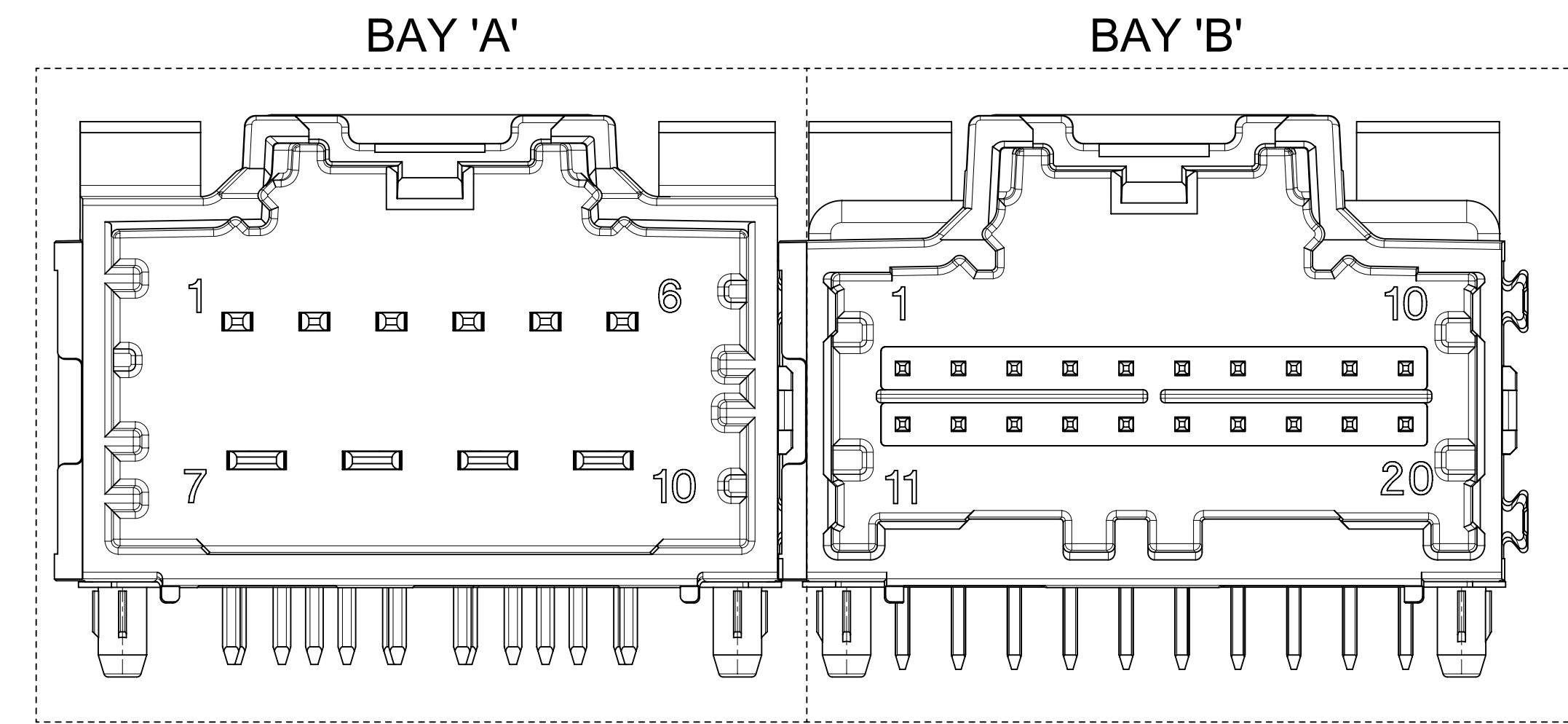

TABLE OF CONTENTS	
1	NOTES, INSPECTION BALLOON NUMBER LOG, REV. TABLE, 2 BAY ASSEMBLY VIEW
2	DIMENSIONAL CHART FOR MULTIBAY CONFIGURATION
3	DIMENSIONAL CHART FOR MULTIBAY CONFIGURATION
4	2 BAY ASSEMBLY VIEW, RECOMMENDED PCB LAYOUT, FLUSH MOUNTING VIEW, POST HOLE TABLE, DIMENSION DETAILS
5	8-20CKT 0.64MM HEADER DETAILS, 14CKT HYBRID HEADER DETAILS, 10CKT HYBRID HEADER DETAILS
6	RECOMMENDED SINGLE PCB LAYOUT FOR 10CKT HYBRID, 14CKT HYBRID, AND 8-20CKT 0.64MM

Y3 NOTES: VALID UNLESS OTHERWISE SPECIFIED

1. GENERAL:
 - a. CONNECTOR HEADER MUST BE VALIDATED TO THE FOLLOWING FUNCTIONAL REQUIREMENTS:
 PRODUCT SPECIFICATION:
 8-20 CKT 0.64 PRODUCT SPEC: PS-34729-020/PS-31408-100
 10/14 CKT HYBRID PRODUCT SPEC: PS-31372-100
 - b. APPLICATION REQUIREMENTS (REFERENCE ONLY):
 APPLICATION SPECIFICATION: AS-34729-020/AS-31408-100
 - c. PACKAGING SPECIFICATION PER MOLEX DRAWING PK-31300-892 (TRAY)
 - d. PACKAGING SPECIFICATION PER MOLEX DRAWING PK-31301-063 (TUBE)
 - e. PACKAGING SPECIFICATION PER MOLEX DRAWING PK-31300-894 (ALT TRAY)
2. MATERIALS:
 - a. SHROUD (PLASTIC HOUSING):
 RESIN - SPS
 COLOR:
 POL A - BLACK
 POL B - GRAY
 POL C - BROWN
 POL D - GREEN
 - b. 0.64mm PINS:
 BASE MATERIAL: COPPER ALLOY
 PLATING TYPE: AS NOTED
 1.5/2.8mm BLADES:
 BASE MATERIAL: COPPER ALLOY
 PLATING TYPE: AS NOTED
3. PLATING REQUIREMENTS:
 - a. UNDERPLATING - OVERALL NICKEL
 - b. OVERPLATING - OVERALL TIN
4. FOR ADDITIONAL INFORMATION AND DIMENSIONS OF INDIVIDUAL BAYS REFER TO THE FOLLOWING SINGLE BAY DRAWINGS:
 8-20 CKT 0.64: SD-34691-100
 10 CKT HYBRID: SD-34696-100
 14 CKT HYBRID: SD-34773-010
5. G DENOTES DIMENSIONS THAT MAY BE QUALIFIED WITH A GAUGE.

Y5	ADDED P/NS 34708-2051 AND 34708-2052 IN SHEET 3	679095	2021.09
Y4	ADDED P/N 34708-2049 IN SHEET 3	670800	2021.07
Y3	1. UPDATED NOTES 2. ADDED NEW P/NS 34708-2048 AND 34708-7048 IN SHEET 3	662724	2021.05
REV.	REV. DESCRIPTION	EC#	DATE

INSPECTION BALLOON NUMBER LOG	
PER DRAWING REVISION:	Y5
LAST BALLOON NUMBER USED:	55
ADDED BALLOON NUMBERS:	
REMOVED BALLOON NUMBERS:	

FUNCTIONAL SYMBOLS FA = 0 FC = 0 FP = 0	THIS DRAWING CONTAINS INFORMATION THAT IS PROPRIETARY TO MOLEX ELECTRONIC TECHNOLOGIES, LLC AND SHOULD NOT BE USED WITHOUT WRITTEN PERMISSION	DIMENSION UNITS: mm SCALE: 4:1	CURRENT REV DESC: EC NO: 679095 DRWN: CZHANG118 2021/09/27 CHK'D: CDZHANG 2021/10/08 APPR: CDZHANG 2021/10/08			
	GENERAL TOLERANCES (UNLESS SPECIFIED) ANGULAR TOL ± 3.0°	4 PLACES ± 3 PLACES ± 2 PLACES ± 0.13 1 PLACE ± 0.25 0 PLACES ±	INITIAL REVISION: DRWN: MBAILEY 2008/08/14 APPR: SMARCEAU 2008/08/14	PRODUCT CUSTOMER DRAWING		
	DRAFT WHERE APPLICABLE MUST REMAIN WITHIN DIMENSIONS	THIRD ANGLE PROJECTION	D-SIZE 34708	MATERIAL NUMBER SEE CHART	CUSTOMER GENERAL MARKET	SHEET NUMBER 1 OF 6
	DOCUMENT NUMBER: SD-34708-200		DOC TYPE: PSD	DOC PART: 001	REVISION: Y5	

DOCUMENT STATUS	P1	RELEASE DATE	2021/10/08	03:36:02

DIMENSIONAL CHART FOR MULTIBAY CONFIGURATION:

2 BAY PART NUMBER (ALT TRAY)	2 BAY PART NUMBER (TUBE PKG)	2 BAY PART NUMBER (TRAY PKG)	BAY A			BAY B			DIM 'A'	DIM 'B'	DIM 'C'	DIM 'D'
			CKT	TYPE	POL	CKT	TYPE	POL				
TBD	34708-7000	34708-2000	20	0.64mm	A	20	0.64mm	B	66.94	64.47	27.94	27.94
TBD	TBD	34708-2001	20	0.64mm	B	20	0.64mm	C	66.94	64.47	27.94	27.94
TBD	TBD	34708-2002	20	0.64mm	C	20	0.64mm	D	66.94	64.47	27.94	27.94
TBD	34708-7003	34708-2003	20	0.64mm	C	8	0.64mm	A	51.70	49.23	27.94	12.70
TBD	34708-7004	34708-2004	20	0.64mm	C	12	0.64mm	A	56.78	54.31	27.94	17.78
TBD	TBD	34708-2005	14	HYBRID	C	20	0.64mm	C	66.94	64.47	27.94	27.94
TBD	TBD	34708-2006	16	0.64mm	B	20	0.64mm	B	61.86	59.39	22.86	27.94
TBD	TBD	34708-2007	16	0.64mm	C	20	0.64mm	C	61.86	59.39	22.86	27.94
TBD	TBD	34708-2008	20	0.64mm	A	20	0.64mm	C	66.94	64.47	27.94	27.94
TBD	TBD	34708-2009	8	0.64mm	A	8	0.64mm	B	36.46	33.99	12.70	12.70
TBD	TBD	34708-2010	12	0.64mm	A	10	HYBRID	B	56.78	54.31	17.78	27.94
TBD	TBD	34708-2011	20	0.64mm	C	20	0.64mm	B	66.94	64.47	27.94	27.94
TBD	TBD	34708-2012	10	HYBRID	A	20	0.64mm	C	66.94	64.47	27.94	27.94
TBD	TBD	34708-2013	12	0.64mm	A	20	0.64mm	B	56.78	54.31	17.78	27.94
TBD	TBD	34708-2014	14	HYBRID	C	20	0.64mm	B	66.94	64.47	27.94	27.94
TBD	TBD	34708-2015	20	0.64mm	B	14	HYBRID	C	66.94	64.47	27.94	27.94
TBD	TBD	34708-2016	12	0.64mm	B	20	0.64mm	D	56.78	54.31	17.78	27.94
TBD	TBD	34708-2017	16	0.64mm	A	8	0.64mm	C	46.62	44.15	22.86	12.70
TBD	TBD	34708-2018	12	0.64mm	A	16	0.64mm	A	51.70	49.23	22.86	17.78
TBD	TBD	34708-2019	20	0.64mm	A	12	0.64mm	A	56.78	54.31	27.94	17.78
TBD	34708-7012	34708-2020	10	HYBRID	A	16	0.64mm	A	61.86	59.39	27.94	22.86
TBD	TBD	34708-2021	16	0.64mm	B	16	0.64mm	A	56.78	54.31	22.86	22.86
TBD	TBD	34708-2022	20	0.64mm	C	10	HYBRID	A	66.94	64.47	27.94	27.94
TBD	TBD	34708-2023	20	0.64mm	A	20	0.64mm	C	66.94	64.47	27.94	27.94
TBD	TBD	34708-2024	8	0.64mm	A	10	HYBRID	A	51.70	49.23	12.70	27.94
TBD	TBD	34708-2025	8	0.64mm	B	10	HYBRID	A	51.70	49.23	12.70	27.94
TBD	TBD	34708-2026	16	0.64mm	A	20	0.64mm	A	61.86	59.39	22.86	27.94
TBD	TBD	34708-2027	8	0.64mm	B	8	0.64mm	B	36.46	33.99	12.70	12.70
TBD	TBD	34708-2028	16	0.64mm	A	8	0.64mm	A	46.62	44.15	22.86	12.70
TBD	TBD	34708-2029	12	0.64mm	A	12	0.64mm	B	46.62	44.15	17.78	17.78
TBD	34708-7030	34708-2030	10	HYBRID	B	10	HYBRID	A	66.94	64.47	27.94	27.94
TBD	TBD	34708-2031	12	0.64mm	B	12	0.64mm	A	46.62	44.15	17.78	17.78
TBD	TBD	34708-2032	20	0.64mm	D	16	0.64mm	B	61.68	59.39	27.94	22.86
TBD	TBD	34708-2033	20	0.64mm	D	16	0.64mm	C	61.86	59.39	27.94	22.86
TBD	TBD	34708-2034	16	0.64mm	B	20	0.64mm	D	61.68	59.39	22.86	27.94
TBD	TBD	34708-2035	16	0.64mm	C	20	0.64mm	D	61.86	59.39	22.86	27.94
TBD	TBD	34708-2036	8	0.64mm	C	16	0.64mm	C	46.62	44.15	12.70	22.86
34708-7537	TBD	34708-2037	16	0.64mm	A	10	HYBRID	B	61.86	59.39	22.86	27.94
34708-7538	TBD	34708-2038	10	HYBRID	A	16	0.64mm	C	61.86	59.39	27.94	22.86
TBD	TBD	34708-2039	14	HYBRID	A	20	0.64mm	D	66.94	64.47	27.94	27.94
TBD	TBD	34708-2040	20	0.64mm	A	8	0.64mm	A	51.70	49.23	27.94	12.70
TBD	TBD	34708-2041	12	0.64mm	B	16	0.64mm	A	51.70	49.23	17.78	22.86
TBD	TBD	34708-2042	16	0.64mm	A	16	0.64mm	A	56.78	54.31	22.86	22.86
TBD	TBD	34708-2043	20	0.64mm	B	20	0.64mm	A	66.94	64.47	27.94	27.94
TBD	TBD	34708-2044	10	HYBRID	A	10	HYBRID	B	66.94	64.47	27.94	27.94
TBD	TBD	34708-2045	20	0.64mm	A	14	HYBRID	B	66.94	64.47	27.94	27.94
TBD	TBD	34708-2046	20	0.64mm	C	14	HYBRID	A	66.94	64.47	27.94	27.94

FUNCTIONAL SYMBOLS FA = 0 FE = 0 FP = 0	THIS DRAWING CONTAINS INFORMATION THAT IS PROPRIETARY TO MOLEX ELECTRONIC TECHNOLOGIES, LLC AND SHOULD NOT BE USED WITHOUT WRITTEN PERMISSION		CURRENT REV DESC:		 <p align="center">2-BAY STAC64 RIGHT ANGLE HEADER ASSEMBLY SALES DRAWING</p> <p align="center">PRODUCT CUSTOMER DRAWING</p>
	DIMENSION UNITS	SCALE	EC NO: 679095 DRWN: CZHANG118 2021/09/27 CHK'D: CDZHANG 2021/10/08 APPR: CDZHANG 2021/10/08		
DIVISIONAL SYMBOLS	GENERAL TOLERANCES (UNLESS SPECIFIED)		INITIAL REVISION:		DOCUMENT NUMBER: SD-34708-200 DOC TYPE: PSD DOC PART: 001 REVISION: Y5
	ANGULAR TOL ± 3.0°		DRWN: MBAILEY 2008/08/14 APPR: SMARCEAU 2008/08/14		
	4 PLACES ±	MATERIAL NUMBER		CUSTOMER	
	3 PLACES ±	DRAWING		SHEET NUMBER	
2 PLACES ± 0.13	DRAFT WHERE APPLICABLE MUST REMAIN WITHIN DIMENSIONS		D-SIZE		2 OF 6
1 PLACE ± 0.25	SERIES		SEE CHART		GENERAL MARKET
0 PLACES ±	THIRD ANGLE PROJECTION		34708		

DIMENSIONAL CHART FOR MULTIBAY CONFIGURATION:

2 BAY PART NUMBER (ALT TRAY)	2 BAY PART NUMBER (TUBE PKG)	2 BAY PART NUMBER (TRAY PKG)	BAY A			BAY B			DIM 'A'	DIM 'B'	DIM 'C'	DIM 'D'
			CKT	TYPE	POL	CKT	TYPE	POL				
TBD	TBD	34708-2050	20	0.64mm	A	16	0.64mm	A	61.86	59.39	27.94	22.86
TBD	TBD	34708-2060	10	HYBRID	B	16	0.64mm	A	61.86	59.39	27.94	22.86
TBD	TBD	34708-2070	16	0.64mm	A	12	0.64mm	A	51.70	49.23	22.86	17.78
TBD	TBD	34708-2080	16	0.64mm	A	16	0.64mm	B	56.78	54.31	22.86	22.86
TBD	TBD	34708-2090	16	0.64mm	B	16	0.64mm	C	56.78	54.31	22.86	22.86
TBD	TBD	34708-2047	8	0.64mm	A	20	0.64mm	A	51.70	49.23	12.70	27.94
Y3 TBD	34708-7048	34708-2048	10	HYBRID	A	20	0.64mm	D	66.94	64.47	27.94	27.94
Y4 TBD	TBD	34708-2049	14	HYBRID	A	14	HYBRID	B	66.94	64.47	27.94	27.94
Y5 TBD	TBD	34708-2051	14	HYBRID	A	12	0.64mm	A	56.78	54.31	27.94	17.78
Y5 TBD	TBD	34708-2052	14	HYBRID	C	12	0.64mm	B	56.78	54.31	27.94	17.78

FUNCTIONAL SYMBOLS	THIS DRAWING CONTAINS INFORMATION THAT IS PROPRIETARY TO MOLEX ELECTRONIC TECHNOLOGIES, LLC AND SHOULD NOT BE USED WITHOUT WRITTEN PERMISSION		CURRENT REV DESC:		
	DIMENSION UNITS	SCALE			
$F_A = 0$	mm	4:1			2-BAY STAC64 RIGHT ANGLE HEADER ASSEMBLY SALES DRAWING
$F_C = 0$	GENERAL TOLERANCES (UNLESS SPECIFIED)				
$F_P = 0$	ANGULAR TOL $\pm 3.0^\circ$				PRODUCT CUSTOMER DRAWING
DIVISIONAL SYMBOLS	4 PLACES	\pm	EC NO: 679095		
	3 PLACES	\pm	DRWN: CZHANG118 2021/09/27		
	2 PLACES	± 0.13	CHK'D: CDZHANG 2021/10/08		
	1 PLACE	± 0.25	APPR: CDZHANG 2021/10/08		
	0 PLACES	\pm	INITIAL REVISION:		
	DRAFT WHERE APPLICABLE MUST REMAIN WITHIN DIMENSIONS		DRWN: MBAILEY 2008/08/14		DOCUMENT NUMBER SD-34708-200
	THIRD ANGLE PROJECTION		APPR: SMARCEAU 2008/08/14		
	DRAWING		SERIES	MATERIAL NUMBER	DOC TYPE
	D-SIZE		34708	SEE CHART	PSD
	CUSTOMER		GENERAL MARKET		DOC PART
	SHEET NUMBER		3 OF 6		REVISION
					Y5

TABLE OF CONTENTS	
2	BAY ASSEMBLY VIEW, RECOMMENDED PCB LAYOUT, FLUSH MOUNTING VIEW, POST HOLE TABLE, DIMENSION DETAILS



FOR DIM G:	
8-20CKT 0.64mm	18.40 MAX
10/14CKT Hybrid	18.59 MAX

RECOMMENDED PCB LAYOUT
INSERT NECESSARY BAYS USING CHART ON SHEET 2 AND 3

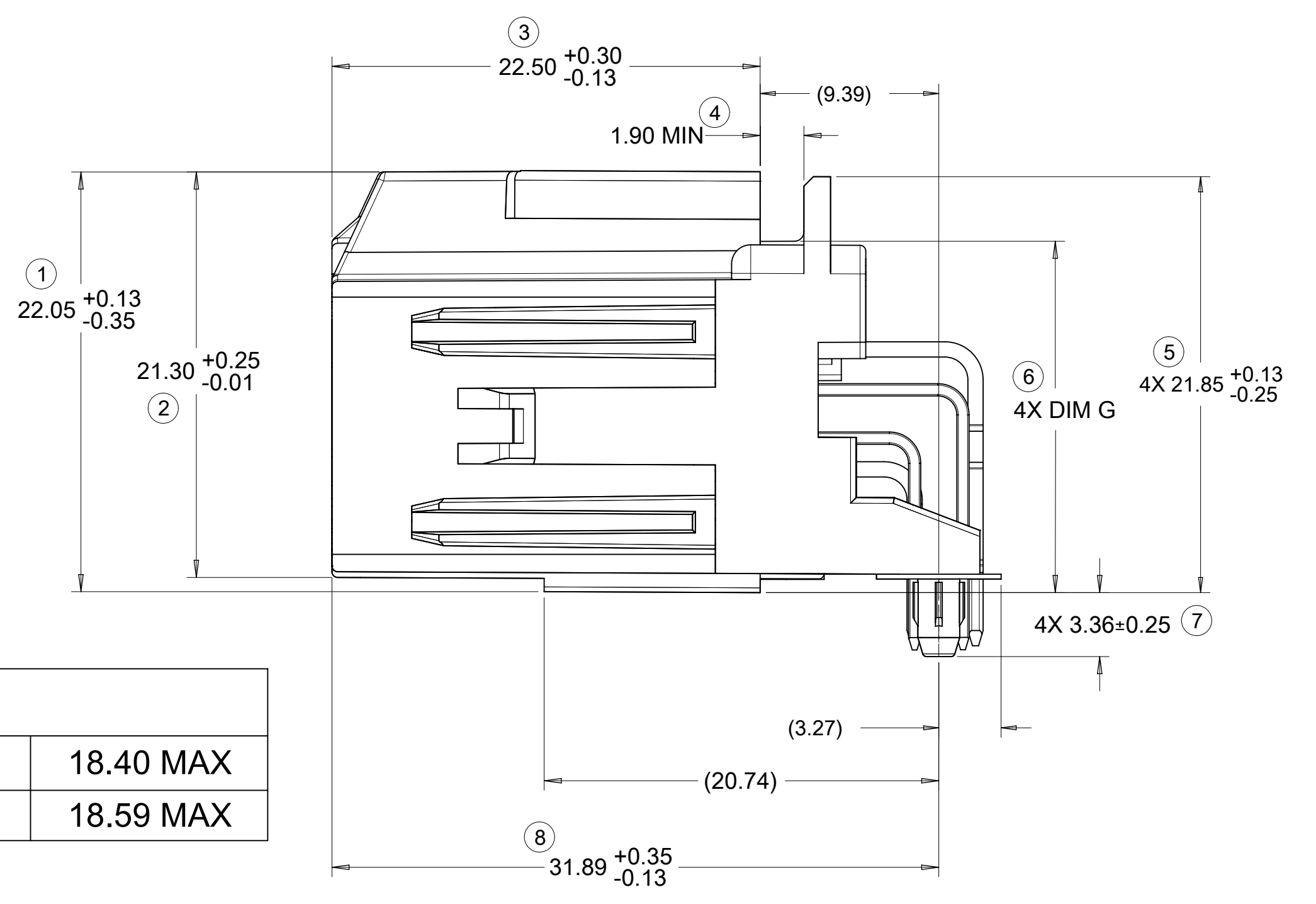
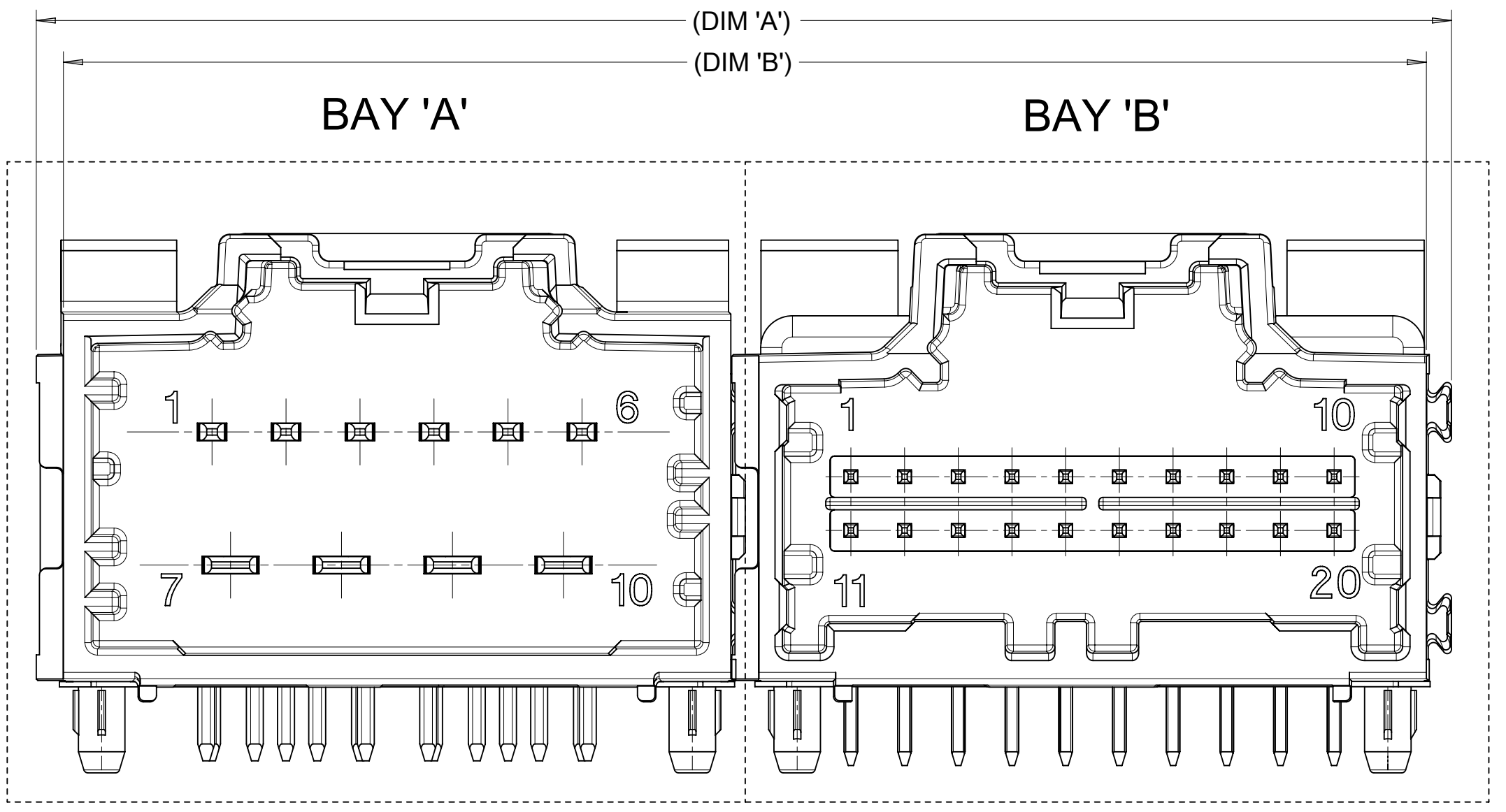
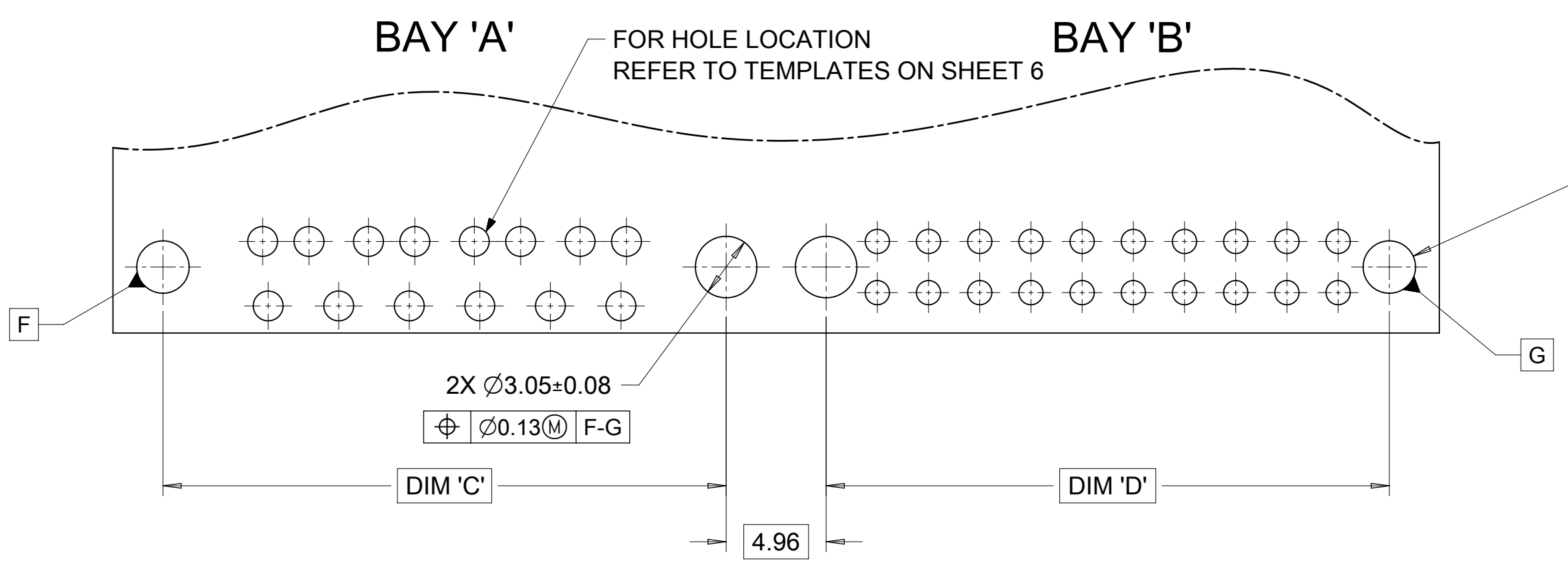

POST HOLE TABLE:

FOR DIM Z:	
PRESS FIT:	2.60
DROP IN:	3.05

ALL CIRCUIT OPTIONS

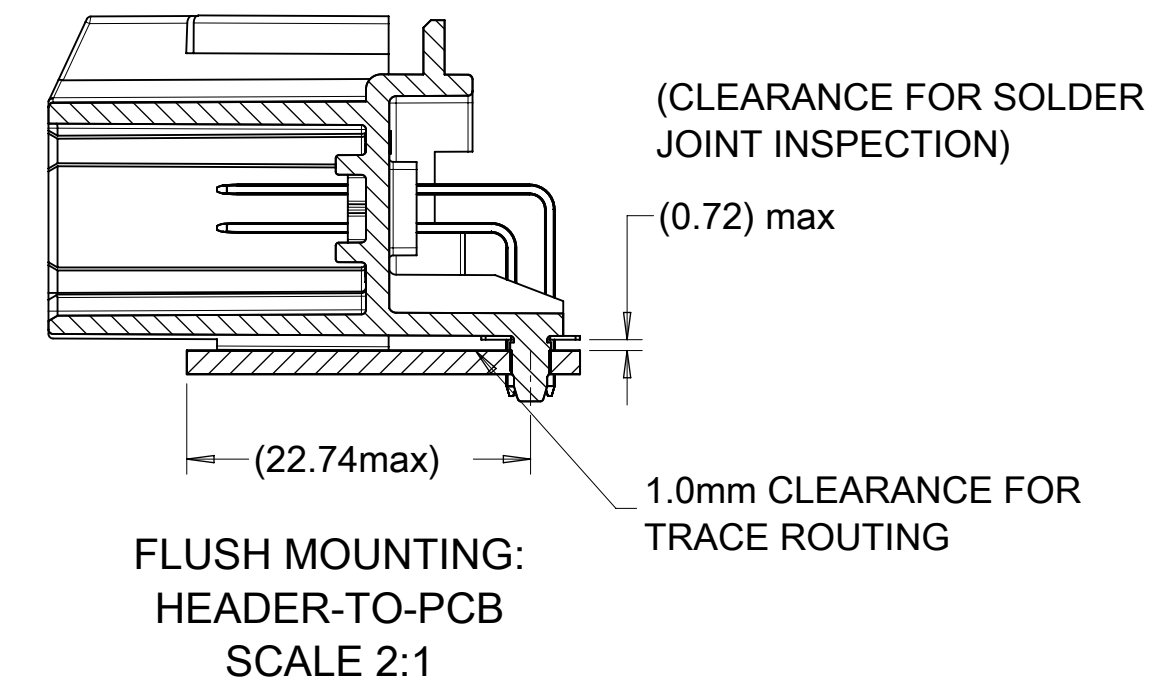

FUNCTIONAL SYMBOLS FA = 0 FE = 0 FP = 0 DIVISIONAL SYMBOLS	THIS DRAWING CONTAINS INFORMATION THAT IS PROPRIETARY TO MOLEX ELECTRONIC TECHNOLOGIES, LLC AND SHOULD NOT BE USED WITHOUT WRITTEN PERMISSION	DIMENSION UNITS: mm SCALE: 4:1 CURRENT REV DESC:			
	GENERAL TOLERANCES (UNLESS SPECIFIED) ANGULAR TOL ± 3.0° 4 PLACES ± 3 PLACES ± 2 PLACES ± 0.13 1 PLACE ± 0.25 0 PLACES ±	EC NO: 679095 DRWN: CZHANG118 2021/09/27 CHK'D: CDZHANG 2021/10/08 APPR: CDZHANG 2021/10/08			
	DRAFT WHERE APPLICABLE MUST REMAIN WITHIN DIMENSIONS	THIRD ANGLE PROJECTION	DRWN: MBAILEY 2008/08/14 APPR: SMARCEAU 2008/08/14	INITIAL REVISION:	DOCUMENT NUMBER: SD-34708-200 DOC TYPE: PSD DOC PART: 001 REVISION: Y5
	D-DRAFT WHERE APPLICABLE MUST REMAIN WITHIN DIMENSIONS	DRAWING: D-SIZE SERIES: 34708	MATERIAL NUMBER: SEE CHART CUSTOMER: GENERAL MARKET	SHEET NUMBER: 4 OF 6	

TABLE OF CONTENTS			
5	8-20CKT 0.64MM HEADER DETAILS, 14CKT HYBRID HEADER DETAILS, 10CKT HYBRID HEADER DETAILS		

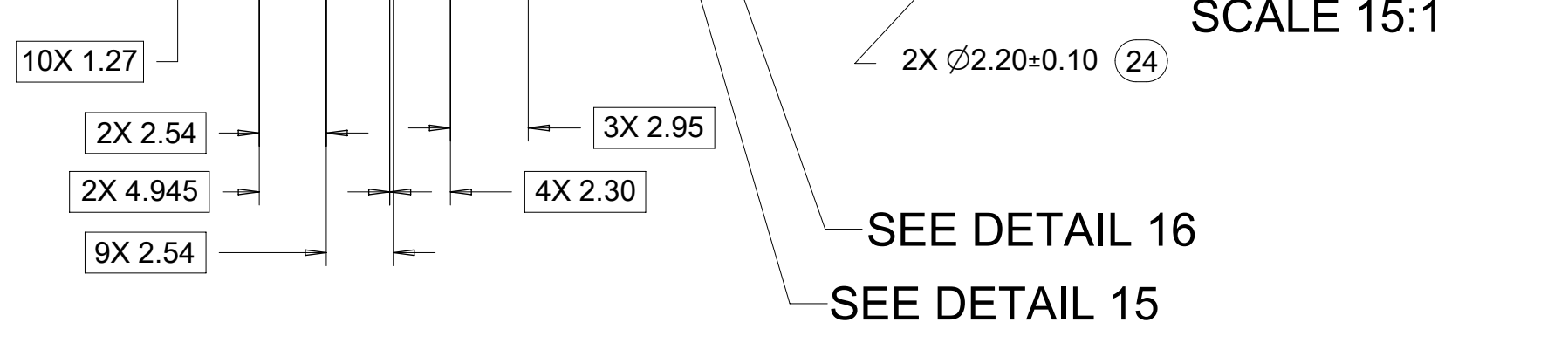
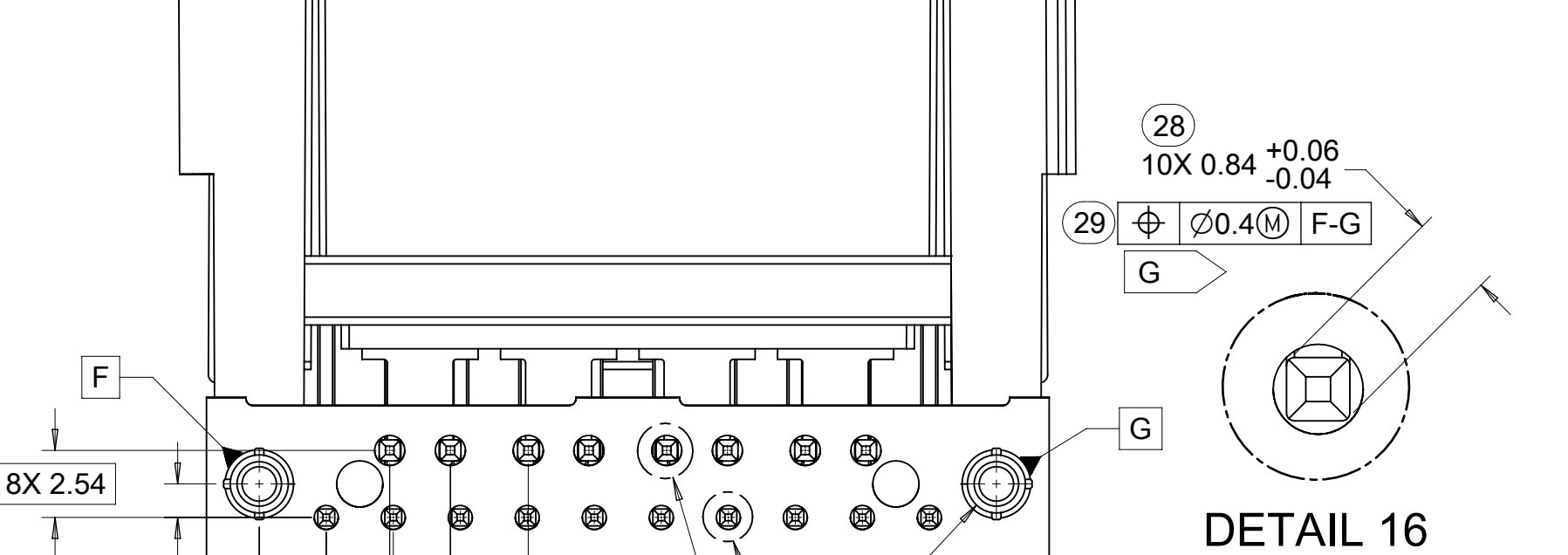
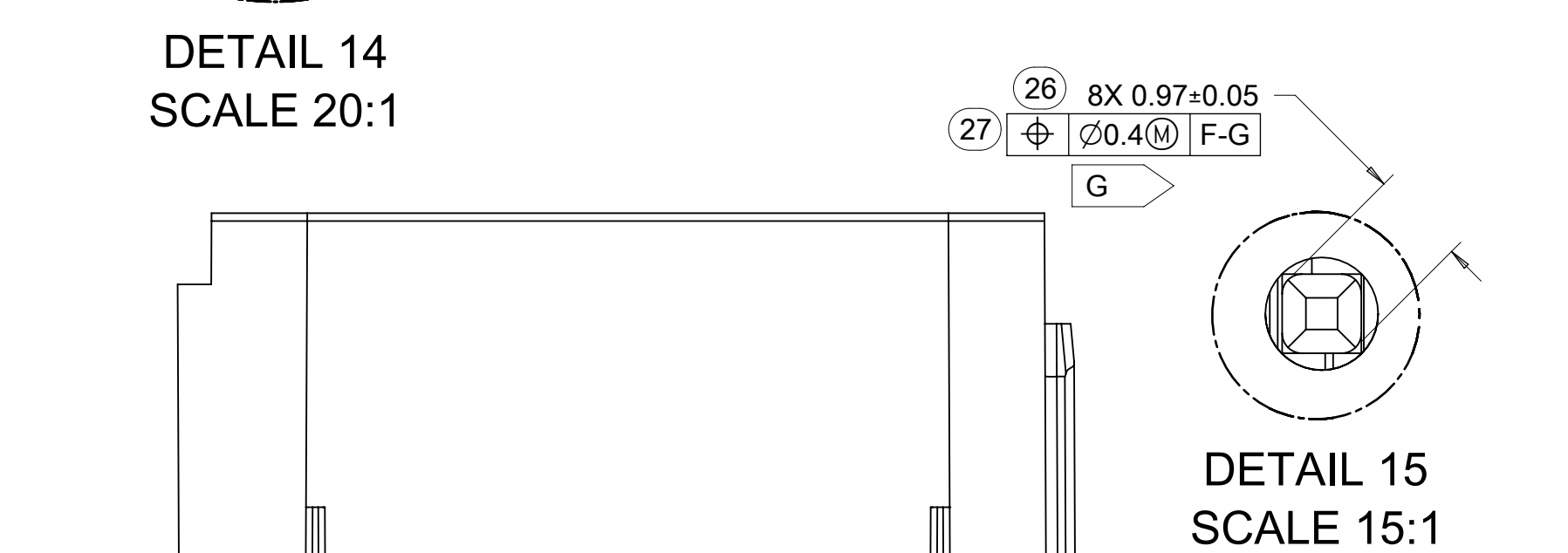
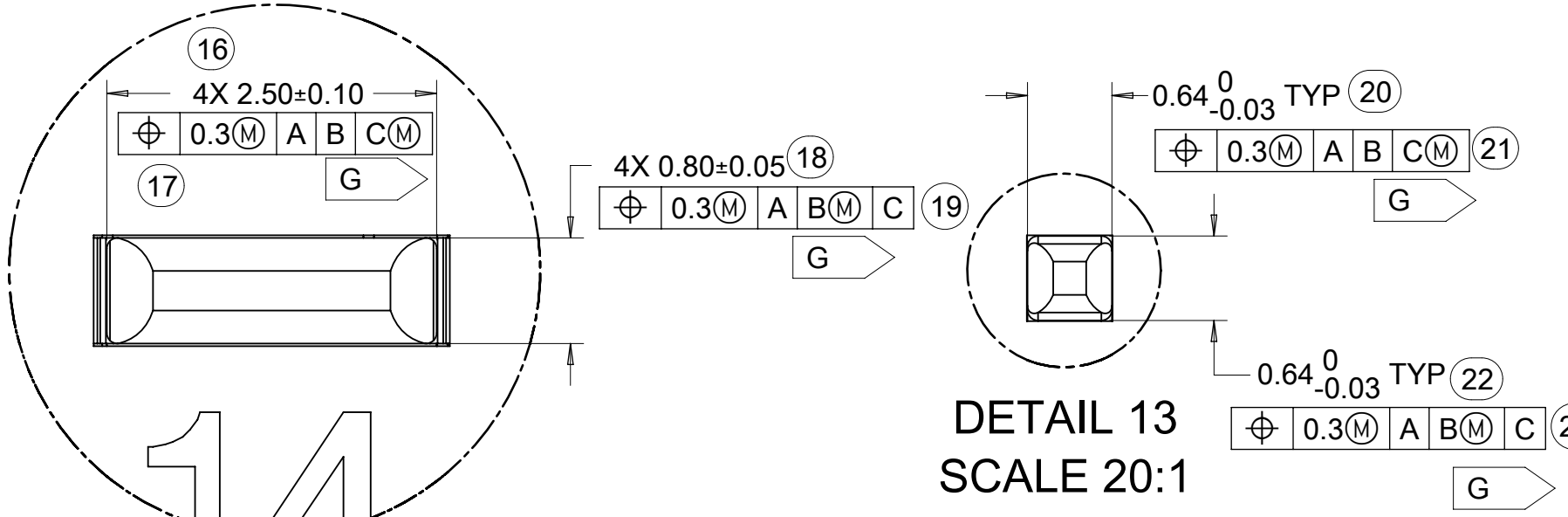
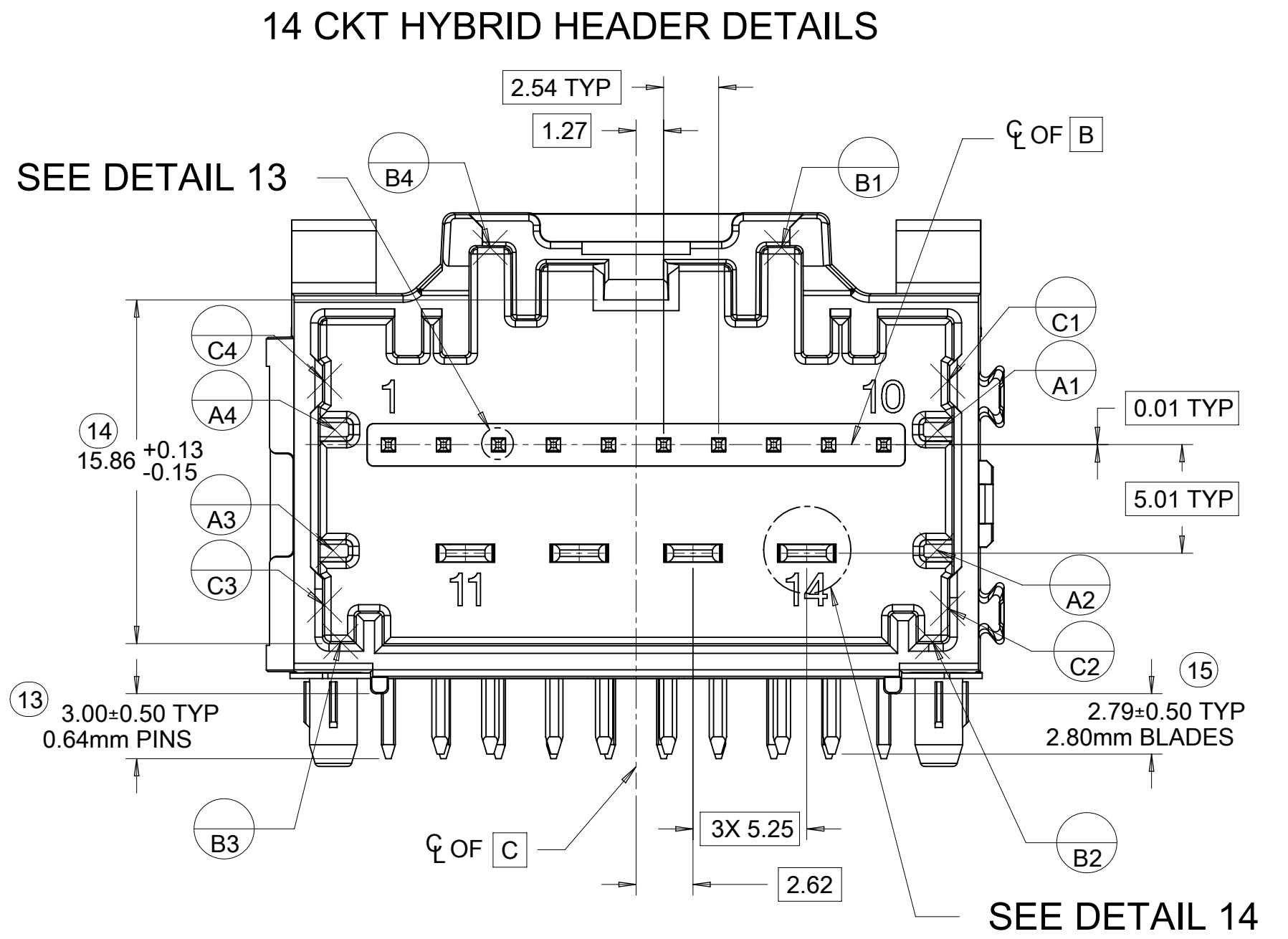

8-20 CKT 0.64mm HEADER DETAILS

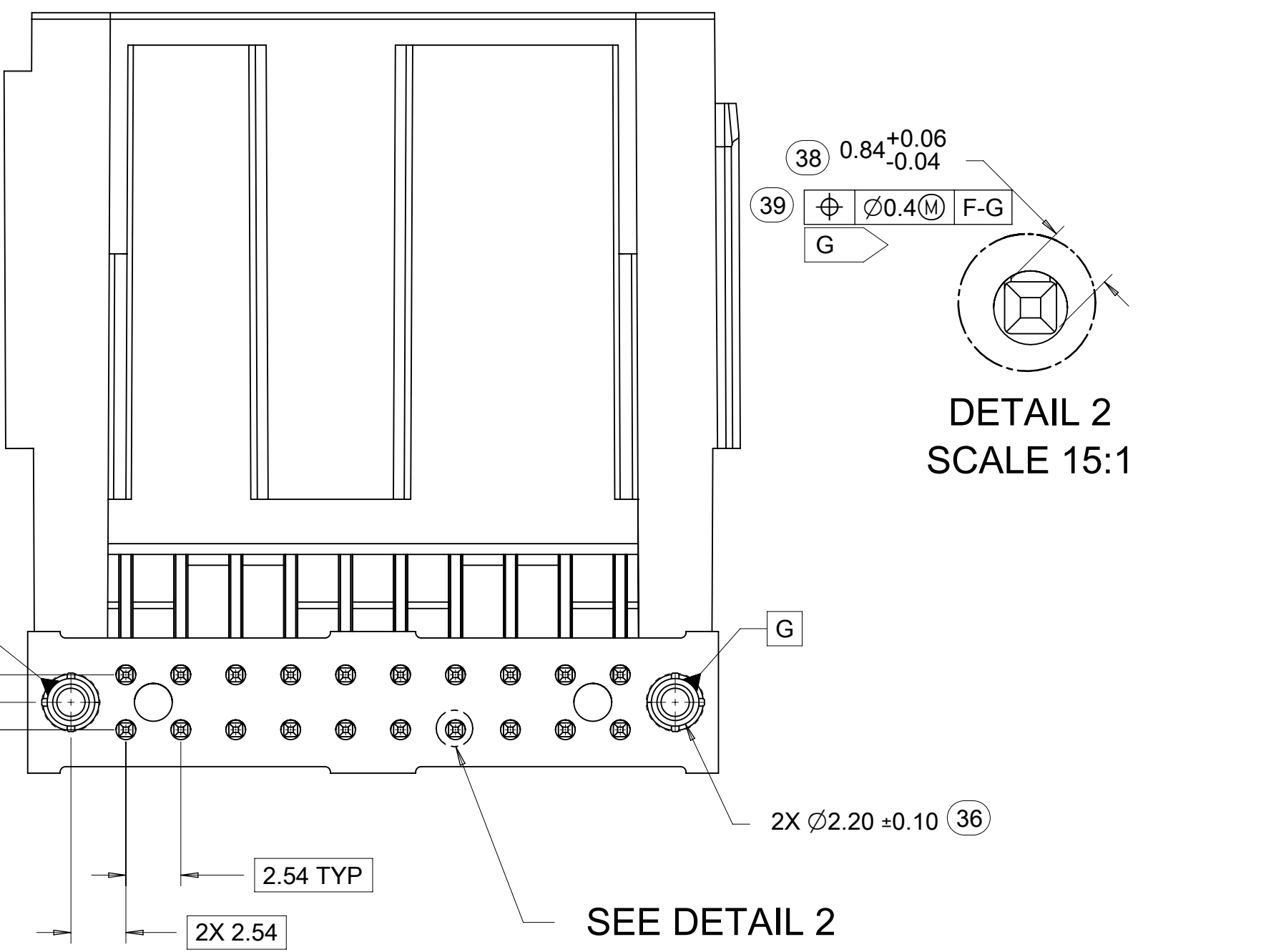
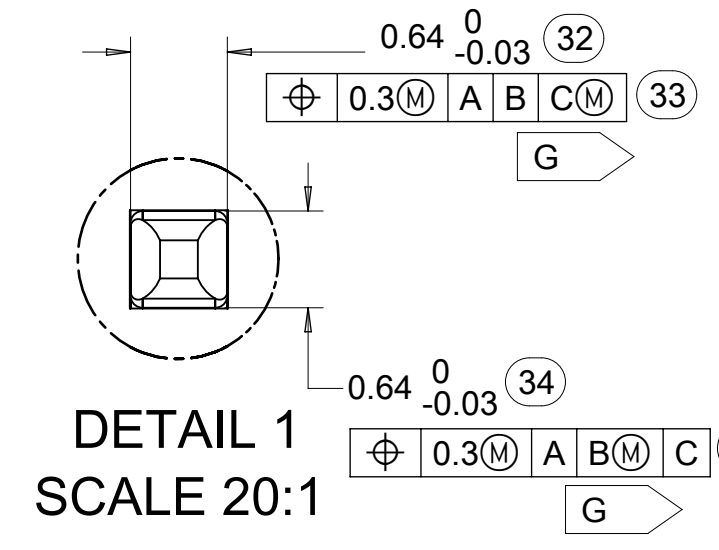
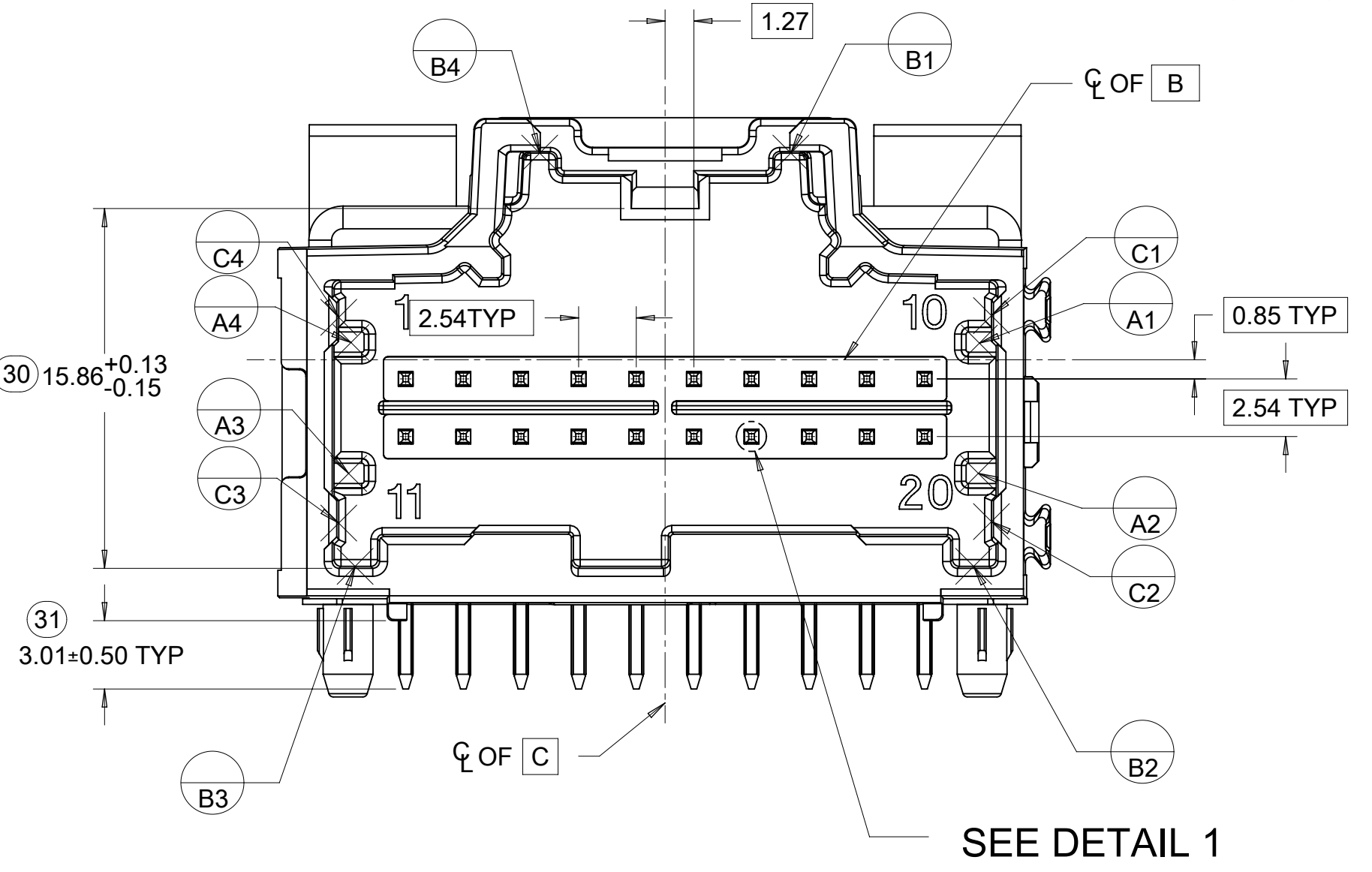

DETAIL 2 SCALE 15:1

10CKT STAC HYBRID HEADER DETAILS

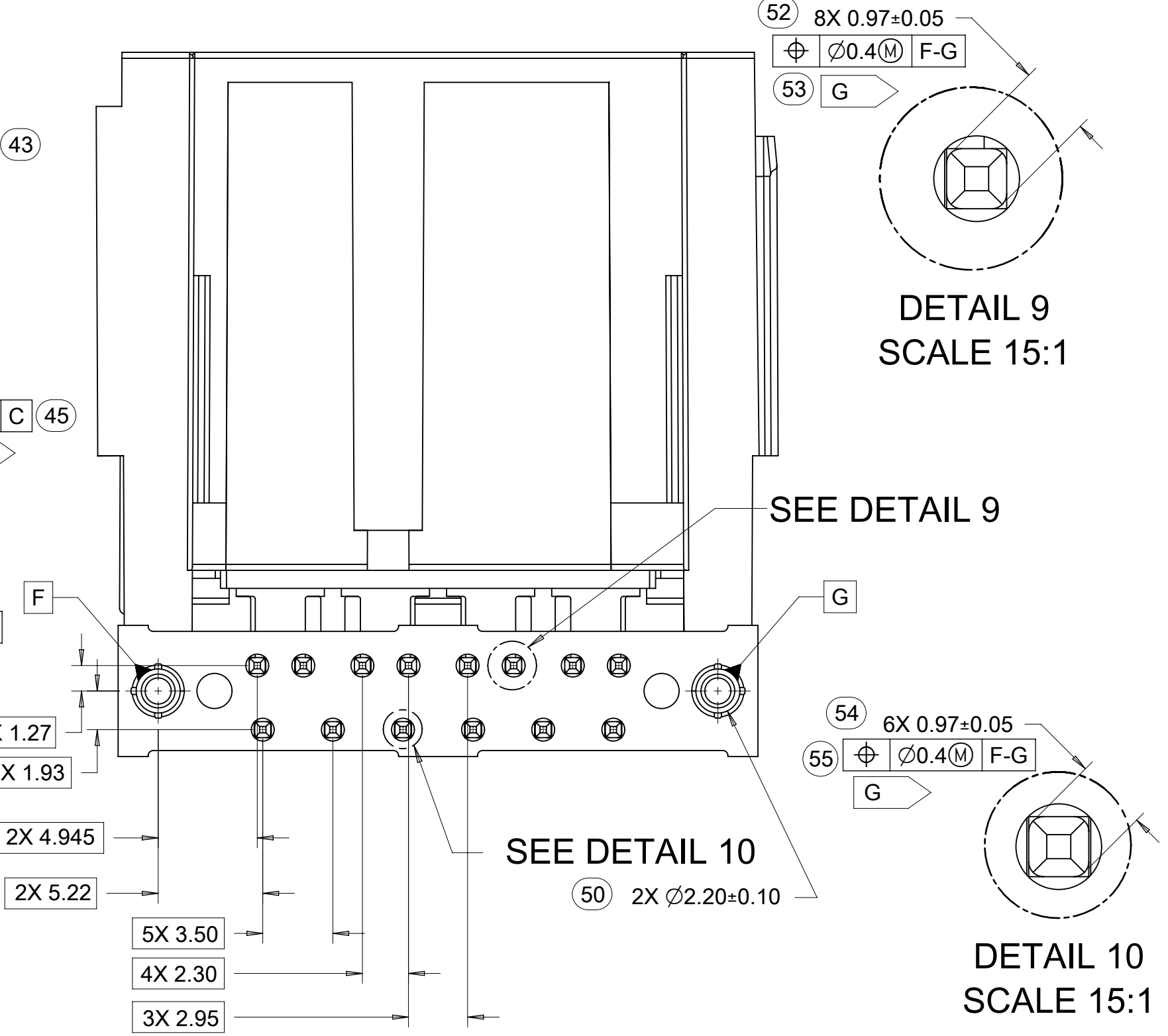
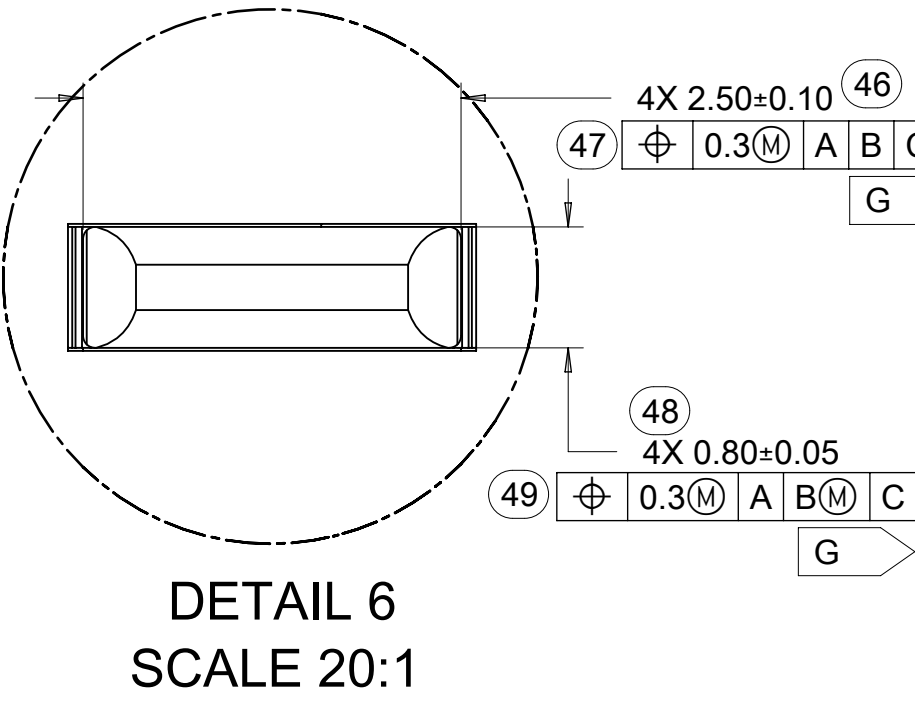
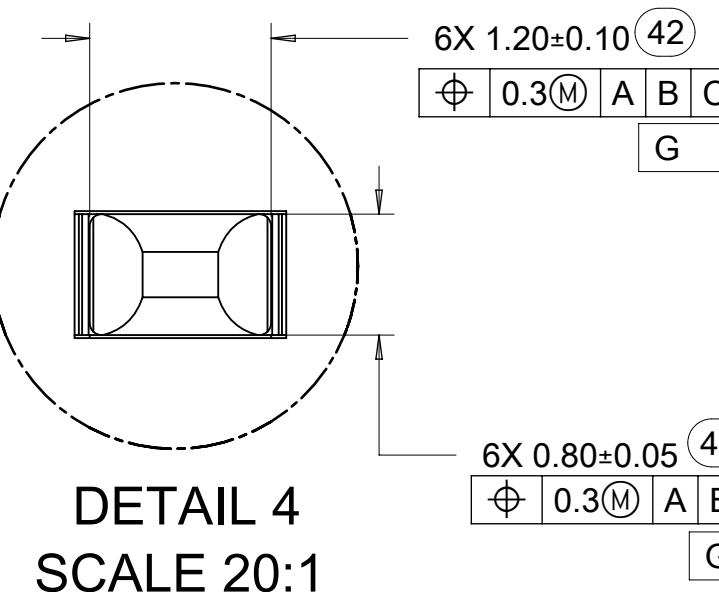
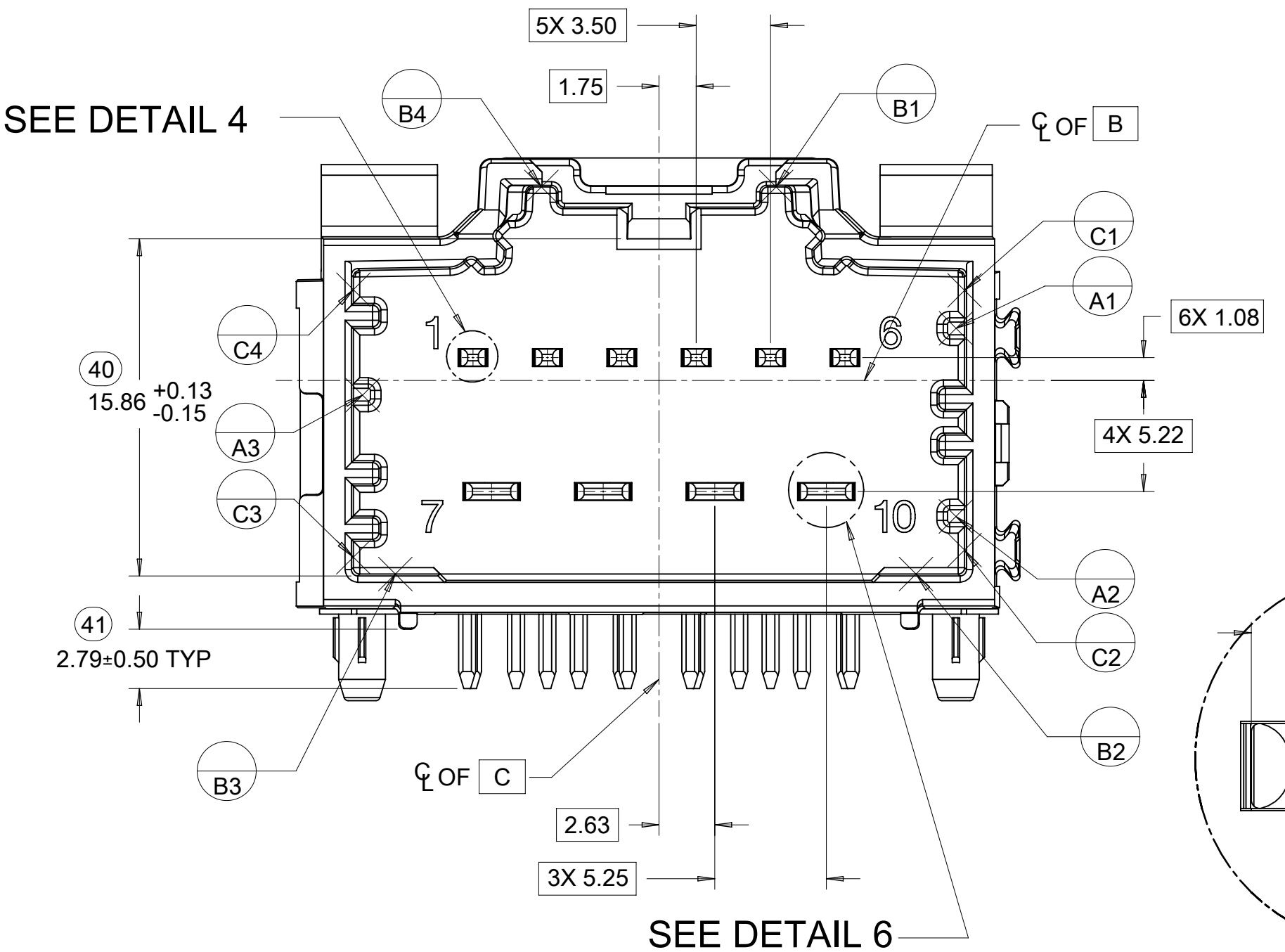

DETAIL 9 SCALE 15:1

DETAIL 10 SCALE 15:1

FUNCTIONAL SYMBOLS		THIS DRAWING CONTAINS INFORMATION THAT IS PROPRIETARY TO MOLEX ELECTRONIC TECHNOLOGIES, LLC AND SHOULD NOT BE USED WITHOUT WRITTEN PERMISSION		CURRENT REV DESC:	
$F_A = 0$	mm	SCALE	4:1		
$F_C = 0$	GENERAL TOLERANCES (UNLESS SPECIFIED)				
$F_P = 0$	ANGULAR TOL		± 3.0°		
DIVISIONAL SYMBOLS	4 PLACES	±			
	3 PLACES	±			
	2 PLACES	± 0.13			
	1 PLACE	± 0.25			
	0 PLACES	±			
DRAFT WHERE APPLICABLE MUST REMAIN WITHIN DIMENSIONS		THIRD ANGLE PROJECTION	DRAWING	SERIES	
			D-SIZE	34708	
		EC NO: 679095		2021/09/27	
		DRWN: CZHANG118		2021/10/08	
		CHK'D: CDZHANG		2021/10/08	
		APPR: CDZHANG			
		INITIAL REVISION:			
		DRWN: MBAILEY		2008/08/14	
		APPR: SMARCEAU		2008/08/14	
DOCUMENT STATUS		DOC TYPE	DOC PART	REVISION	
P1	RELEASE DATE	PSD	001	Y5	
	2021/10/08 03:36:02	SD-34708-200		GENERAL MARKET	5 OF 6

molex

2-BAY STAC64 RIGHT ANGLE
HEADER ASSEMBLY SALES DRAWING

PRODUCT CUSTOMER DRAWING

DOCUMENT NUMBER: SD-34708-200
DOC TYPE: PSD
DOC PART: 001
REVISION: Y5

MATERIAL NUMBER: SEE CHART
CUSTOMER: GENERAL MARKET
SHEET NUMBER: 5 OF 6

10 CKT HYBRID TEMPLATE PCB LAYOUT

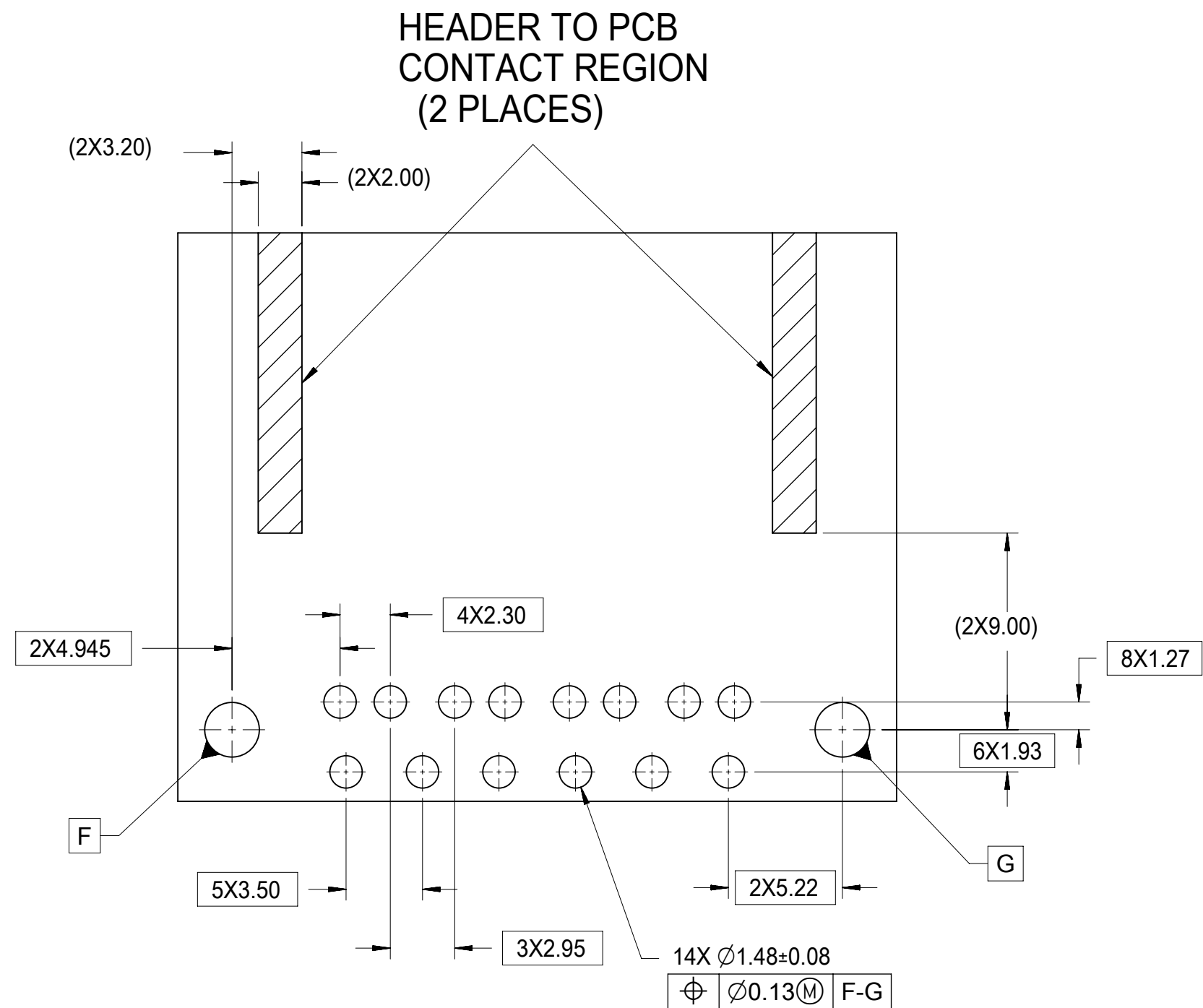

8-20CKT 0.64mm TEMPLATE PCB LAYOUT

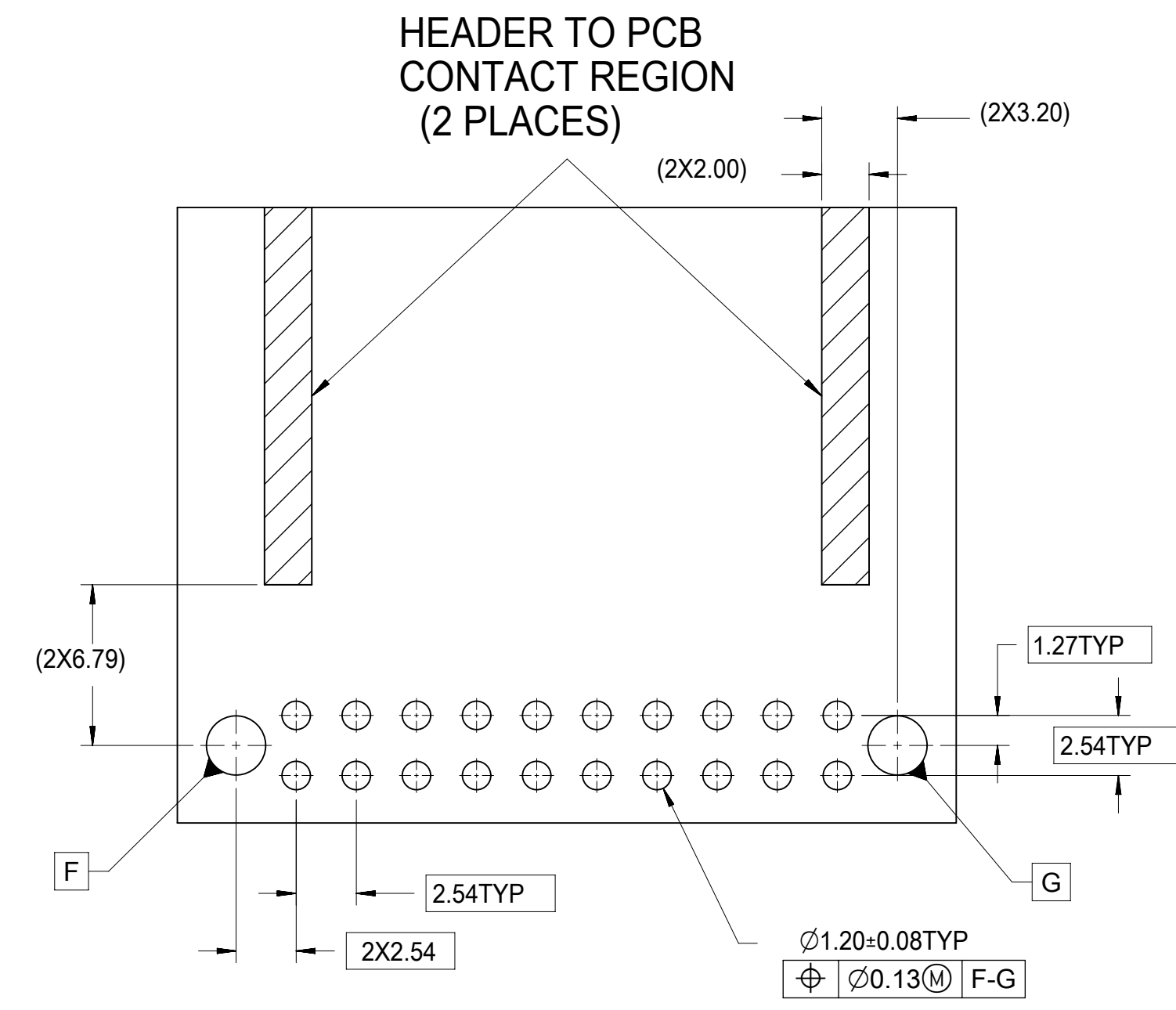

14 CKT HYBRID TEMPLATE PCB LAYOUT

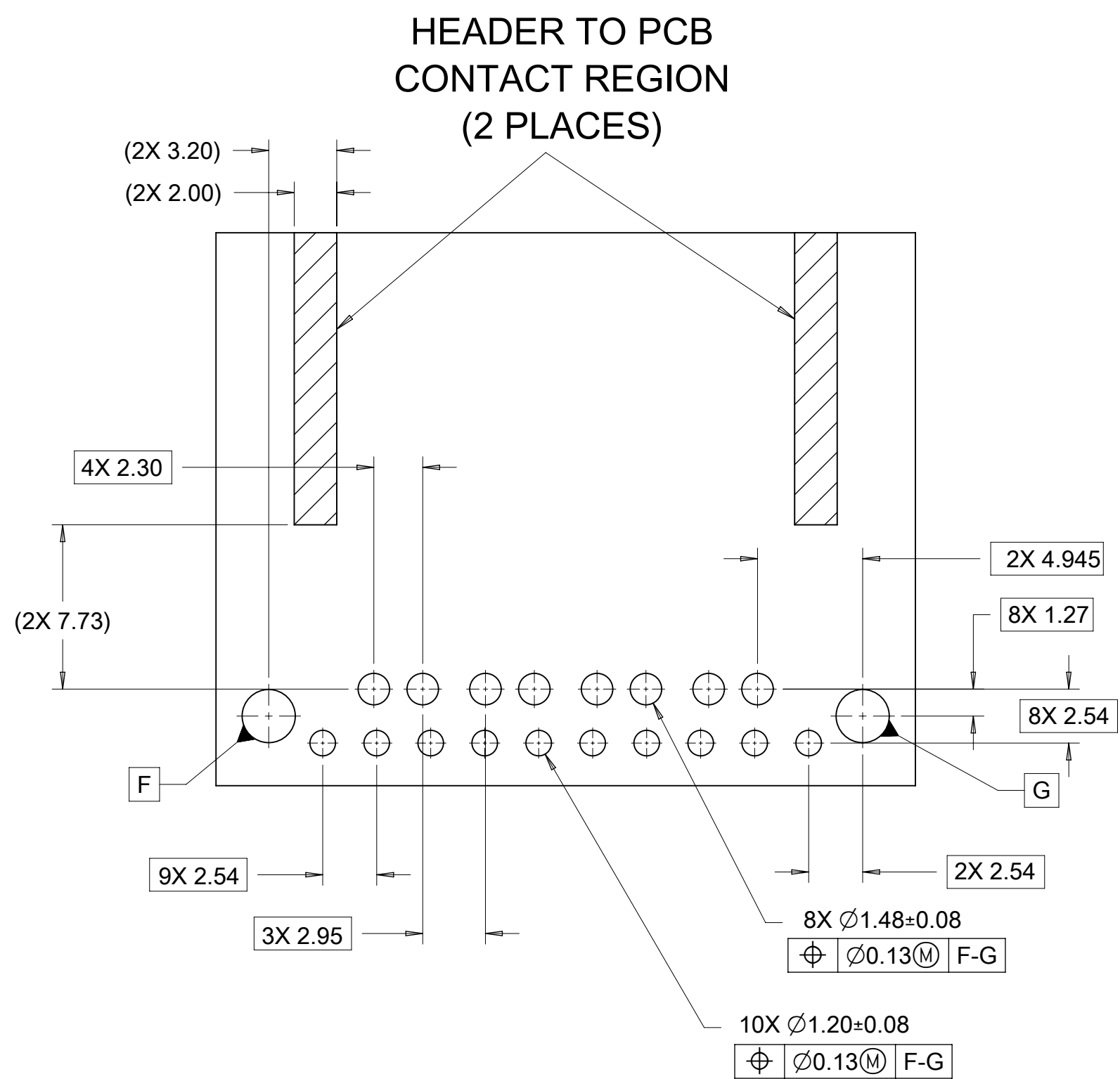

FUNCTIONAL SYMBOLS	THIS DRAWING CONTAINS INFORMATION THAT IS PROPRIETARY TO MOLEX ELECTRONIC TECHNOLOGIES, LLC AND SHOULD NOT BE USED WITHOUT WRITTEN PERMISSION		
	DIMENSION UNITS	SCALE	CURRENT REV DESC:
$\nabla_A = 0$	mm	4:1	
$\nabla_C = 0$	GENERAL TOLERANCES (UNLESS SPECIFIED)		
$\nabla_P = 0$	ANGULAR TOL ± 3.0°		
DIVISIONAL SYMBOLS	4 PLACES	±	EC NO: 679095
	3 PLACES	±	DRWN: CZHANG118 2021/09/27
	2 PLACES	± 0.13	CHK'D: CDZHANG 2021/10/08
	1 PLACE	± 0.25	APPR: CDZHANG 2021/10/08
	0 PLACES	±	INITIAL REVISION:
DRAFT WHERE APPLICABLE MUST REMAIN WITHIN DIMENSIONS		THIRD ANGLE PROJECTION	DRWING
			SERIES
		D-SIZE	34708
		MATERIAL NUMBER	CUSTOMER
		SEE CHART	GENERAL MARKET
		DOCUMENT NUMBER	DOC TYPE DOC PART REVISION
		SD-34708-200	PSD 001 Y5
		SHEET NUMBER	6 OF 6