

PART NUMBER	REVISION	DESCRIPTION	FEED TYPE
2151368-2	B	FINE CRIMP HEIGHT ADJUST	PNEUMATIC
7-2151368-2	B	PNEUMATIC AND CRIMP TOOLING KIT	PNEUMATIC
7-2151368-7	A	CRIMP TOOLING KIT	-

ATLANTIC VERSION TERMINATOR INTERFACE ADAPTER

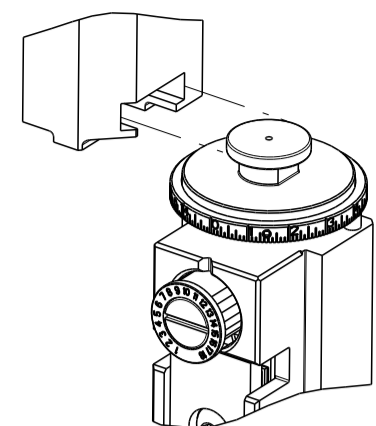

APPLICATOR DATA		
CRIMP	SIZE	TYPE
WIRE	2.85 mm [.112]	F
INSUL	3.85 mm [.152]	OV

APPLICATOR INSTRUCTIONS 408-35042

TERMINAL DATA: FCI TERMINAL		FCI CRIMP SPECIFICATION	
TERMINAL NAME: SICMA-2 FEMALE 2.8mm TERMINAL			
WIRE STRIP LENGTH		INSULATION DIAMETER RANGE	
4.80-5.20 mm [.189-.205 IN]		∅ 3.00 mm [.118 IN] MAX	
TERMINAL APPLICATION SPECIFICATION	FCI SPEC Rev -	-	-
TERMINALS APPLIED			
TE TERMINAL	FCI TERMINAL	TE TERMINAL	FCI TERMINAL
1949375-1	211 CC 3S 2120	1949375-2	211 CC 3S 2220

TERMINAL DATA: FCI TERMINAL		FCI CRIMP SPECIFICATION	
TERMINAL NAME: SICMA-2 FEMALE 2.8mm TERMINAL			
WIRE STRIP LENGTH		INSULATION DIAMETER RANGE	
4.80-5.20 mm [.189-.205 IN]		∅ 3.00 mm [.118 IN] MAX	
TERMINAL APPLICATION SPECIFICATION	FCI SPEC	-	-
TERMINALS APPLIED			
TE TERMINAL	FCI TERMINAL	TE TERMINAL	FCI TERMINAL
1949375-1	211 CC 3S 2120	1949375-2	211 CC 3S 2220

WIRE SIZE	CRIMP HEIGHT mm [INCH]	CRIMP HEIGHT REFERENCE SETTING
2.50mm ²	1.83+/-0.04 [.072+/-0.002]	6.4
(1)1.75mm ² + (1)1.50mm ²	1.76+/-0.04 [.069+/-0.002]	7.1
(1)1.60mm ² + (1)1.40mm ²	1.70+/-0.04 [.067+/-0.002]	7.8
(2) 1.00mm ²	1.69+/-0.04 [.067+/-0.002]	7.9
2.00mm ²	1.68+/-0.04 [.066+/-0.002]	7.9
1.50mm ²	1.62+/-0.04 [.064+/-0.002]	8.4
(1)1.60mm ² + (1)1.00mm ²	1.62+/-0.04 [.064+/-0.002]	8.5
(2) 0.75mm ²	1.60+/-0.04 [.063+/-0.002]	8.7
1.40mm ²	1.58+/-0.04 [.062+/-0.002]	8.9
(1)1.35mm ² + (1)1.00mm ²	1.57+/-0.04 [.062+/-0.002]	9.0
(2) 0.60mm ²	1.55+/-0.04 [.061+/-0.002]	9.1

WIRE SIZE	CRIMP HEIGHT mm [INCH]	CRIMP HEIGHT REFERENCE SETTING
(2) 0.50mm ²	1.51+/-0.04 [.059+/-0.0016]	9.7
(1)0.35mm ² + (1)0.60mm ²	1.50+/-0.04 [.059+/-0.0016]	9.7
1.00mm ²	1.50+/-0.04 [.059+/-0.0016]	9.8

- RECOMMENDED SPARE PARTS
- REFER TO SUPPLIED INSTRUCTION SHEET FOR CLEANING, LUBRICATION AND STORAGE OF APPLICATOR.
- APPLY PART NUMBER 2-23419-6 LOCTITE TO THREADS OF ITEM 242.
- CRIMP HEIGHT REFERENCE SETTING WAS THE SETTING USED WHEN THE APPLICATOR WAS QUALIFIED AT THE FACTORY. ADJUSTMENT MAY BE NECESSARY WHEN RUNNING APPLICATOR IN THE FIELD.
- 5. UNLESS SPECIFIED OTHERWISE TORQUE VALUES SHALL BE USED PER DOCUMENT, 101-35000.

***WARNING**
 ON INSTALLATION, SET WIRE DISC TO CRIMP HEIGHT REFERENCE SETTING FOR LARGEST WIRE SIZE. CRIMP HEIGHT REFERENCE SETTINGS GREATER THAN THE VALUE SHOWN MAY CAUSE DAMAGE TO THE CRIMP TOOLING. REFER TO THE INSTRUCTION SHEET FOR PROPER SETUP AND ADJUSTMENTS.

ATLANTIC VERSION
 Shown on sheets 1 of 4 & 2 of 4
 (Pacific version shown on sheets 3 of 4 & 4 of 4)

LOC	DIST	REVISIONS					
A	66	P	LTN	DESCRIPTION	DATE	OWN	APVD
		A		RELEASE	21FEB2013	XZ	GB
		B		ECR-23-165934	09FEB2023	JWC	ROY

-	1	1	1803945-4	TONKER	300	
-	1	1	22278-9	SPRING, COMPRESSION	299	
-	2	2	4-18032-3	SCR, SET, FLT PNT, M3 X 6.0	298	
-	1	1	1803944-1	SPACER, TONKER	297	
-	1	1	2119641-1	FEED CAM, AIR FEED	248	
-	1	1	2119082-8	CAM, SNAIL, INSULATION ADJUSTMENT	244	
-	1	1	2079764-1	WASHER, WAVE SPRING, CREST-TO-CREST	243	
-	1	1	2119083-1	RETAINER, INSULATION DIAL	242	
-	1	1	7-18023-7	SCR, SKT HD CAP M3 X 4.0	241	
-	1	1	2844940-1	AIR FEED MODULE	238	
-	REF	REF	994970-2	COUNTER, MAGNETIC	164	
-	1	1	1-18028-2	WASHER, FLAT, REG M4	119	
-	1	1	2844908-1	SCREW, LOCKING	99	
-	1	1	2844907-1	POST, LOCKING	98	
-	1	1	455888-8	SPACER, CRIMPER	82	
-	1	1	1803607-3	DOCUMENTATION PACKAGE	71	
-	1	1	2119791-9	DEPRESSOR, WIRE	70	
-	1	1	2119943-1	WASHER, SPACER	69	
-	1	1	2119740-1	TAG, IDENTIFICATION	67	
-	2	2	2168078-1	SCREW, DRIVE, RH, RoHS, 2 x .188	66	
-	1	1	2168083-2	SCR, SKT HD CAP, RoHS, M4 X 8.0	60	
-	1	1	5-18022-5	SCR, HEX HD CAP, M4 X 6.0	59	
-	1	1	1338685-1	PAWL, FEED	56	
-	4	4	2168083-3	SCR, SKT HD CAP, RoHS, M4 X 12.0	54	
-	2	2	2-2168083-5	SCR, SKT HD CAP, RoHS, M4 X 14	53	
-	1	1	18023-9	SCR, SKT HD CAP M4 X 6.0	49	
-	1	1	1803583-9	APPLICATOR BASIC ASSEMBLY, SF	46	
-	1	1	1803515-1	RAM ASSEMBLY, SF ATLANTIC	44	
-	1	1	1803602-1	SCR, BHSC, RoHS (M8 X 25)	41	
-	1	1	1-1752356-3	SUPPORT, TERMINAL	34	
-	2	2	2079383-5	SCR, BHSC, RoHS (M4 X 20)	33	
-	2	2	3-2844962-0	SPACER, CYLINDRICAL, STRIP GUIDE	30	
-	1	1	2844992-1	ASSEMBLY, STRIP GUIDE	29	
-	1	1	1-455888-0	SPACER, CRIMPER	28	
-	1	1	1320928-2	STRIP GUIDE	24	
-	1	1	2168083-2	SCR, SKT HD CAP, RoHS, M4 X 8.0	21	
-	1	1	1-18028-2	WASHER, FLAT, REG M4	20	
-	1	1	2119533-1	STRIPPER, SIDE FEED	19	
-	1	1	2119806-1	INSERT, SHEAR	13	
-	1	1	3-22280-3	SPRING, COMPRESSION	12	
-	1	1	1-356885-4	STOP, SHEAR	11	
-	1	1	2119805-1	SHEAR HOLDER, FRONT	10	
-	1	1	454276-5	FLOATING SHEAR, FRONT	9	
-	1	2	1	6-1633138-8	ANVIL, COMBINATION	8
-	1	1	1	240641-5	SPACER	7
-	-	-	-	-	7	
-	-	-	-	-	6	
-	1	1	1	2119757-8	DEPRESSOR, SHEAR	5
-	1	1	1	1-238011-0	BLOCK, CRIMPER SPACER	4
-	1	2	1	2-2119785-4	CRIMPER, INSULATION OVERLAP PREMIUM	3
-	1	1	1	455888-3	SPACER, CRIMPER	2
-	1	2	1	8-1673600-4	CRIMPER, WIRE	1

DIMENSIONS:		TOLERANCES UNLESS OTHERWISE SPECIFIED:		MATERIAL:		FINISH:	
mm	0 PLC ±	1 PLC ±	2 PLC ±	3 PLC ±	4 PLC ±	ANGLES ±	FINISH ±

ITEM NO	PART NO	DESCRIPTION
-77-72-2		

OWN: X.ZHAO 16AUG2012	CHK: T.ELBIN 16AUG2012	APVD: S.XI 16AUG2012
NAME: Ocean Side Feed Applicator		
SIZE: A1	CAGE CODE: 00779	DRAWING NO: C=2151368
Customer Accessible Production Drawing		
SCALE: 1:2	SHEET: 1	OF: 4
REV: B		

LOC		DIST		REVISIONS			
A	66	P	LTN	DESCRIPTION	DATE	OWN	APVD
		-		SEE SHEET 1	-	-	-

FEED TYPE

PNEUMATIC

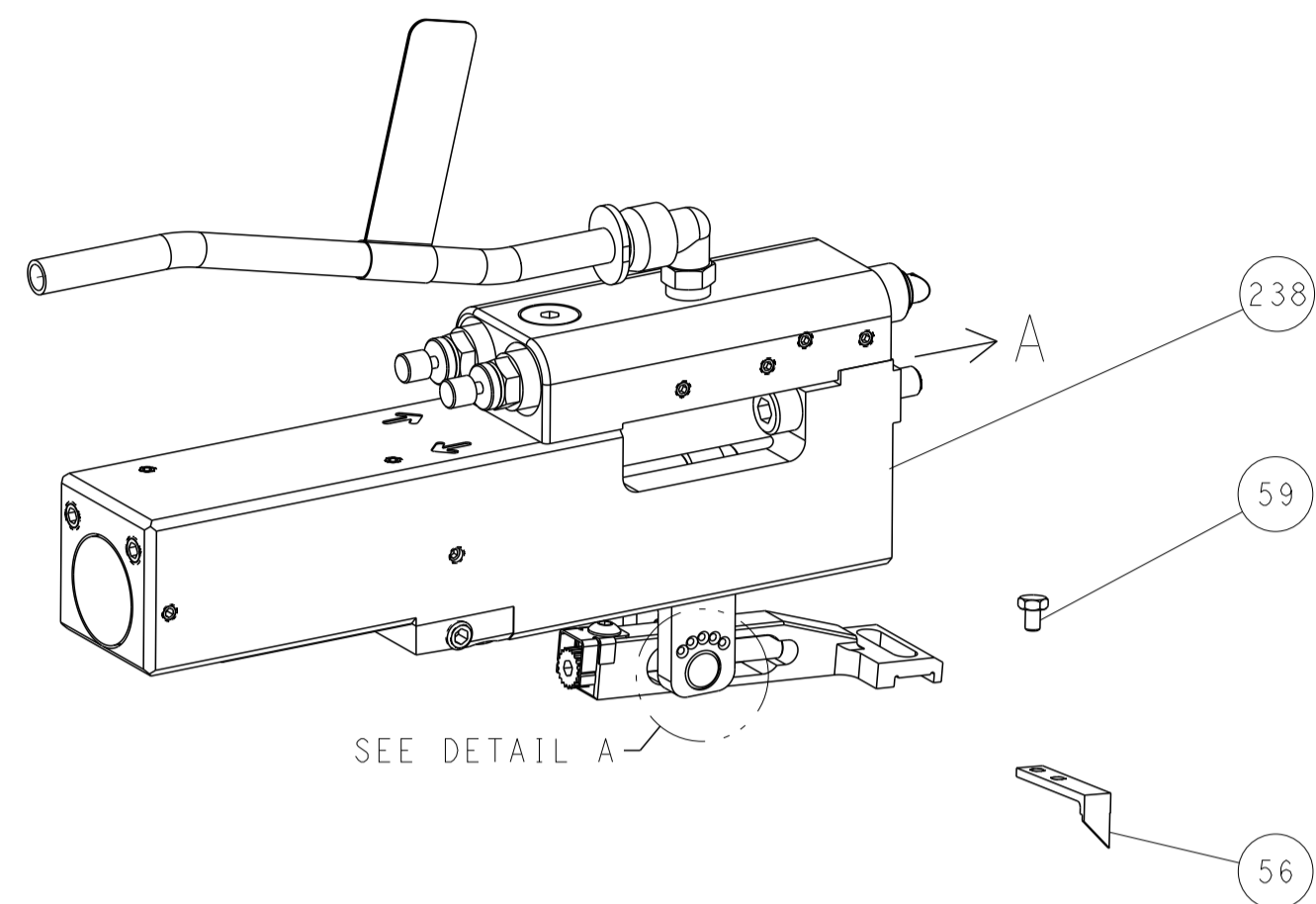

FEED SPRING SETTING POSITION
(SHOWN FROM REAR SIDE)

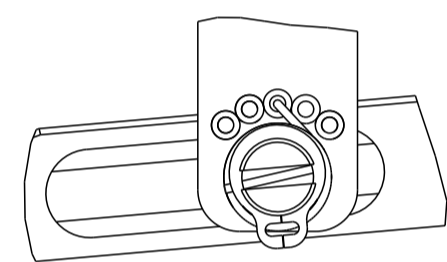

DETAIL A

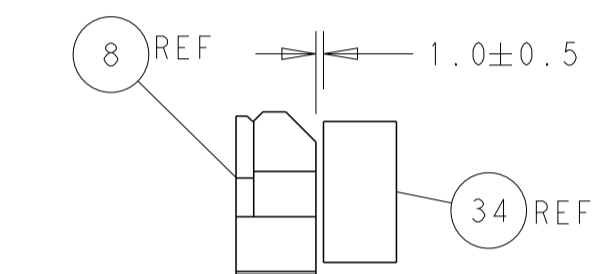
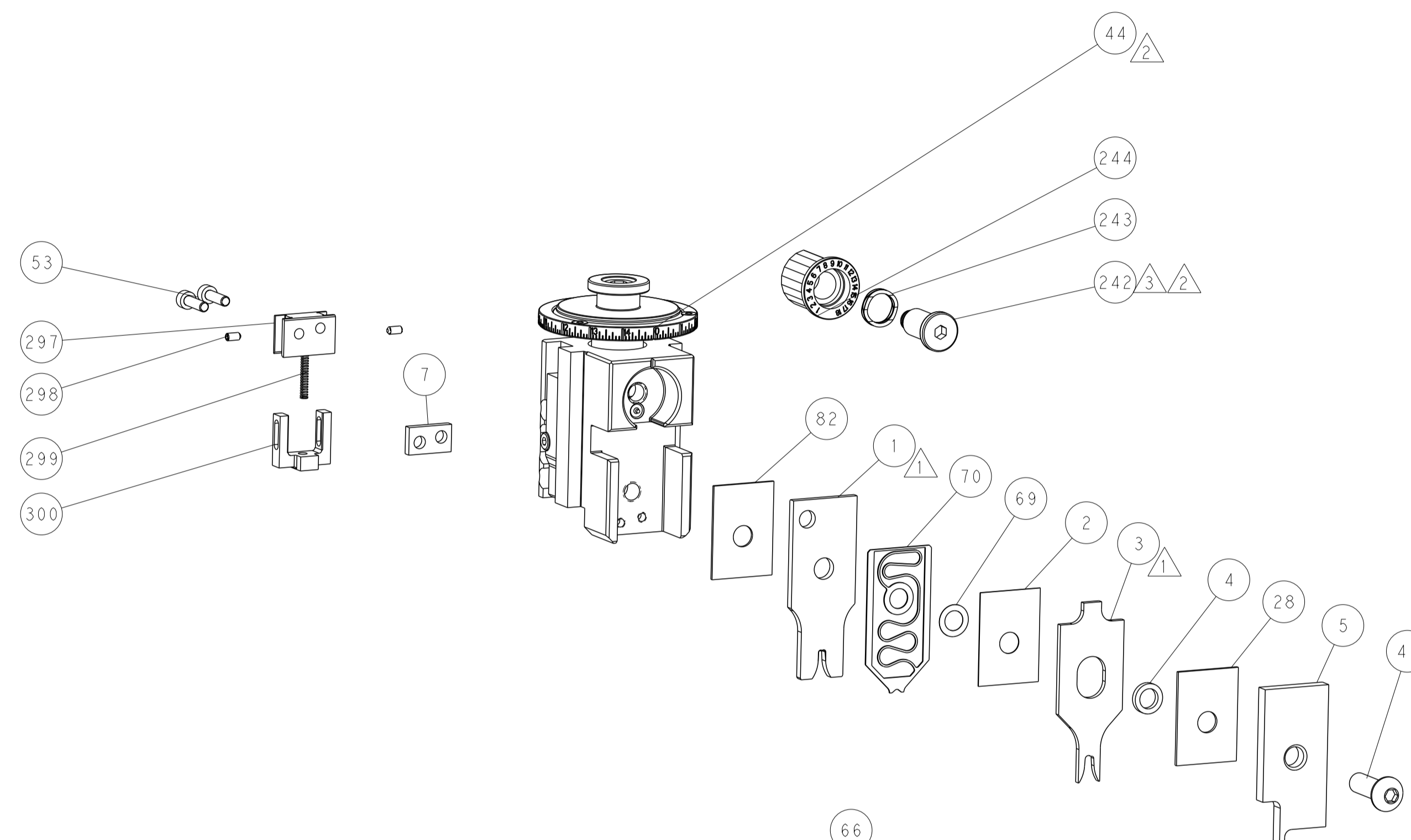

TERMINAL SUPPORT LOCATION

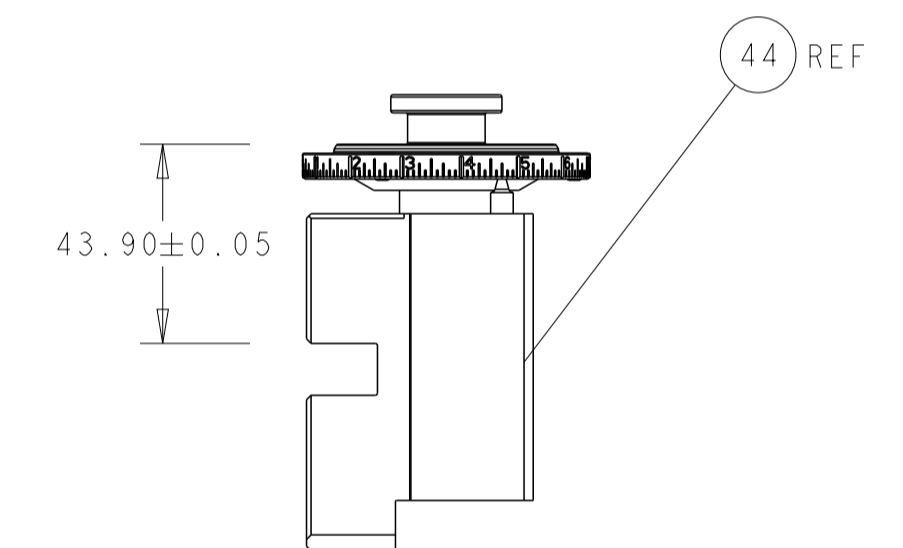

RAM SET-UP

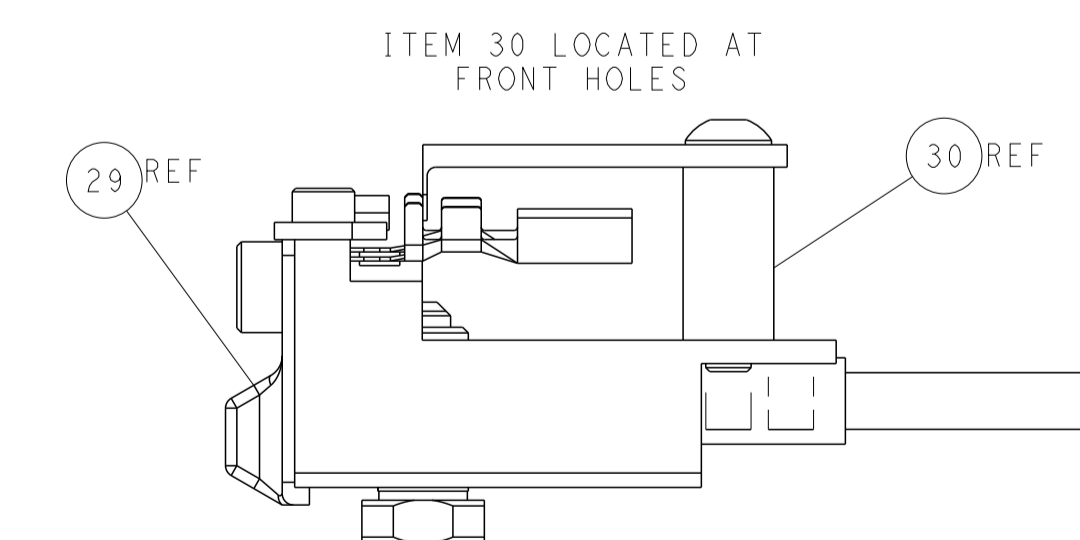
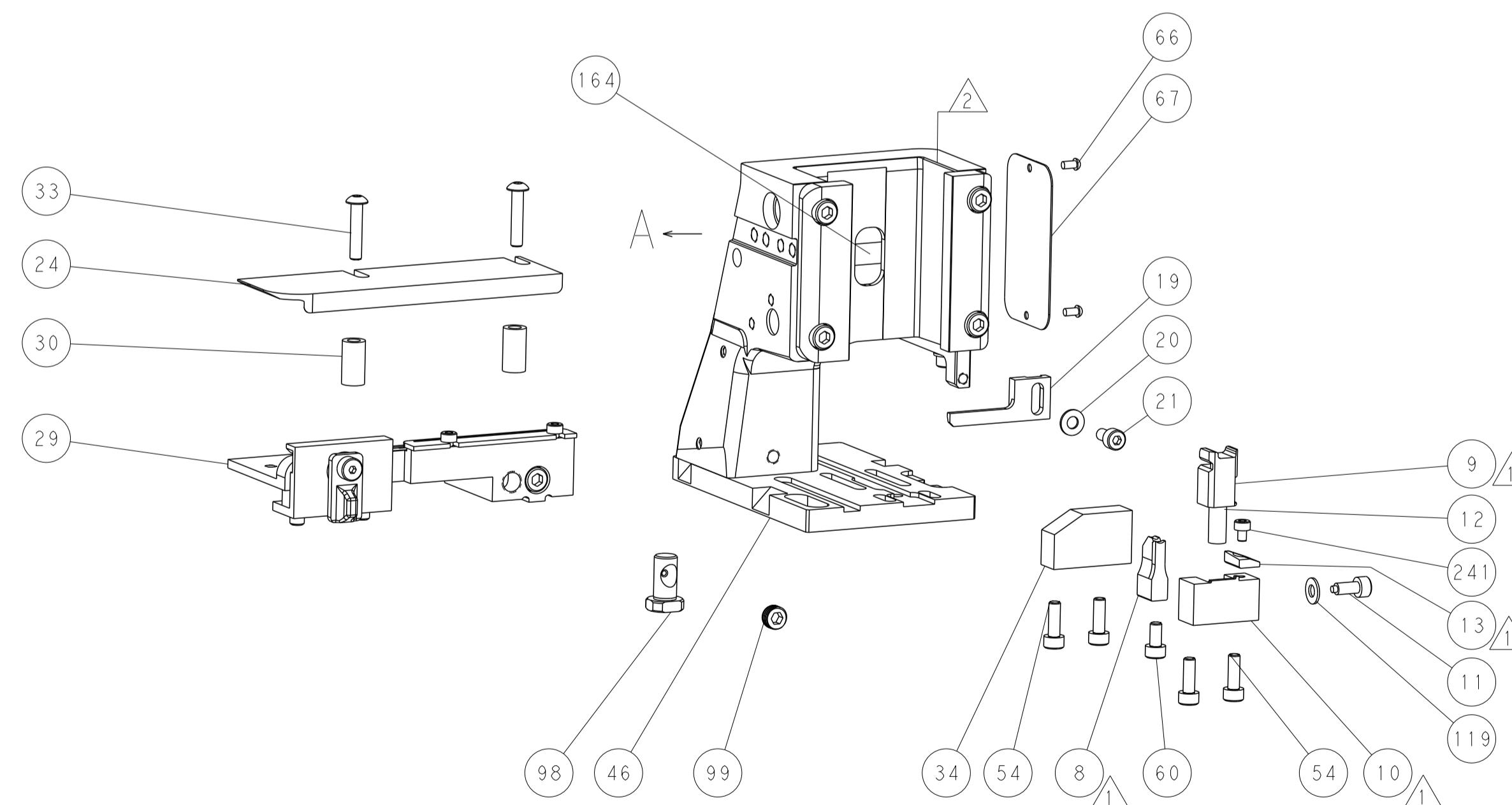

FEED TRACK POSITION
GUIDE BY INSULATION BARREL

CAM POSITION

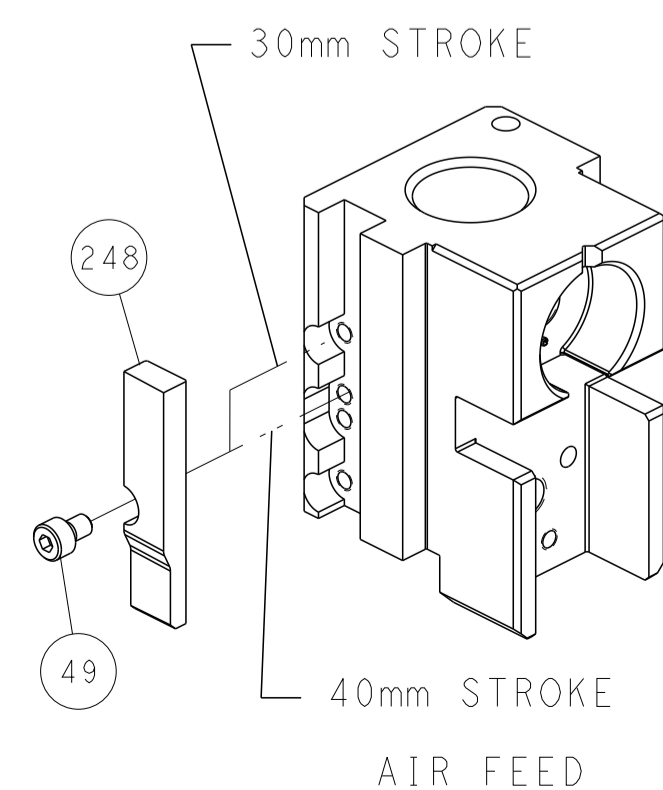

ATLANTIC VERSION
 Shown on sheets 1 of 4 & 2 of 4
 (Pacific version shown on sheets 3 of 4 & 4 of 4)

DIMENSIONS:		TOLERANCES UNLESS OTHERWISE SPECIFIED:		DWN X.ZHAO 16AUG2012		TE Connectivity	
mm	0 PLC ±	1 PLC ±	2 PLC ±	3 PLC ±	4 PLC ±	Harrisburg, PA 17105-3608	
MATERIAL:		FINISH:		APVD S.XI 16AUG2012		NAME	
				PRODUCT SPEC		Ocean Side Feed	
				APPLICATION SPEC		Applicator	
				WEIGHT		RESTRICTED TO	
				A 00779 C=2151368		SCALE 1:2 SHEET 2 OF 4 REV B	
Customer Accessible Production Drawing				SHEETS 3 & 4 ARE NOT REQUIRED FOR ATLANTIC VERSION			

LOC		DIST		REVISIONS			
A	66	P	LTN	DESCRIPTION	DATE	DMN	APVD
		-		SEE SHEET 1	-	-	-

FEED TYPE

PNEUMATIC

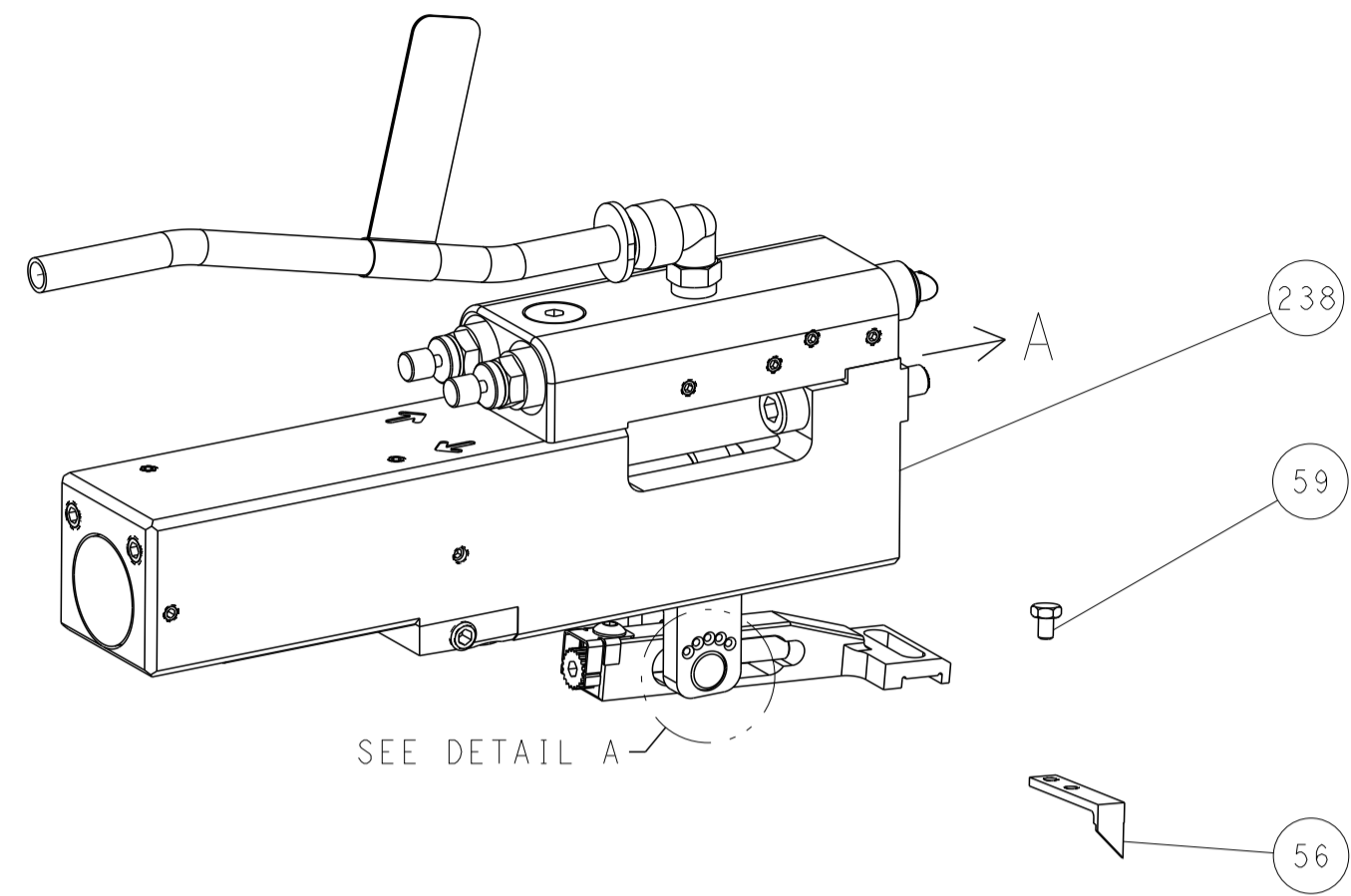

SEE DETAIL A

FEED SPRING SETTING POSITION
(SHOWN FROM REAR SIDE)

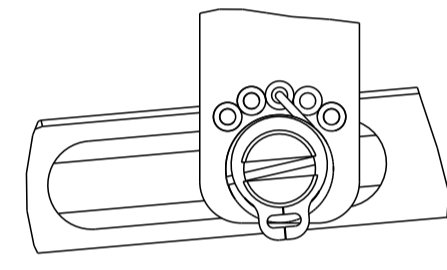

DETAIL A

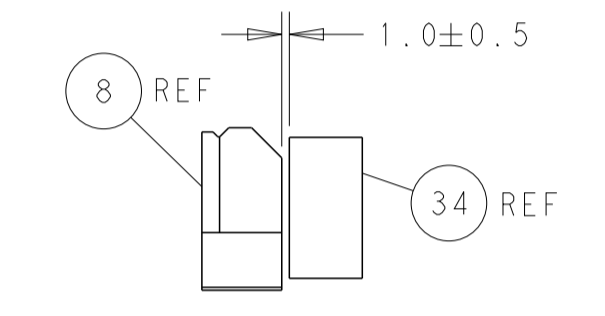
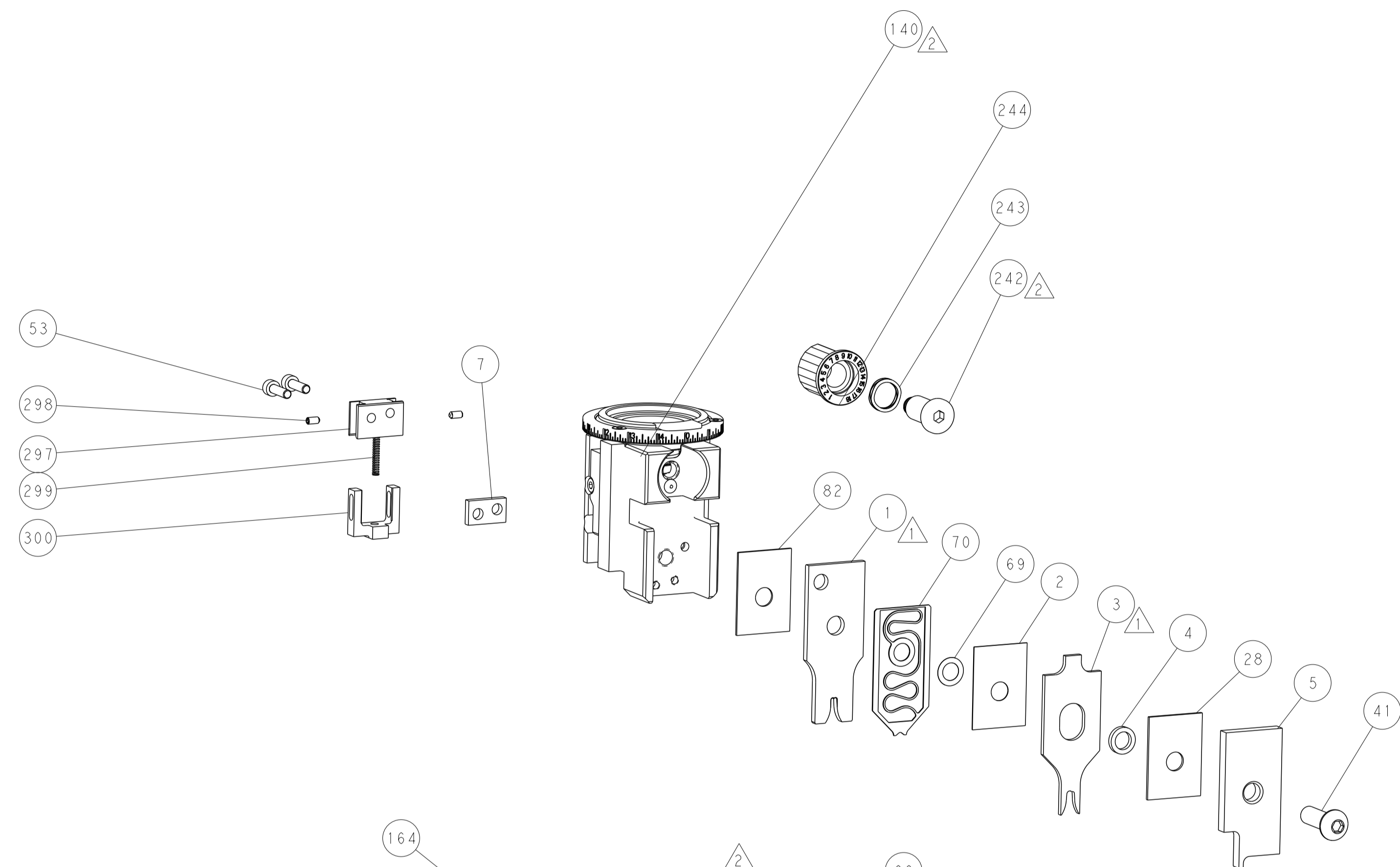

TERMINAL SUPPORT LOCATION

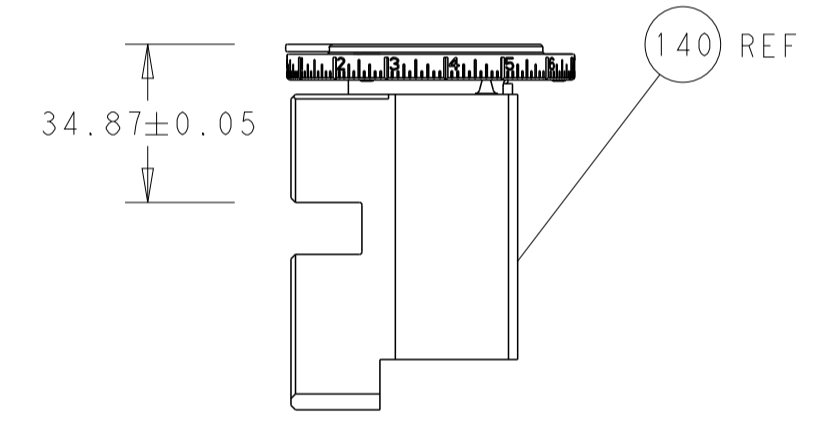

RAM SET-UP

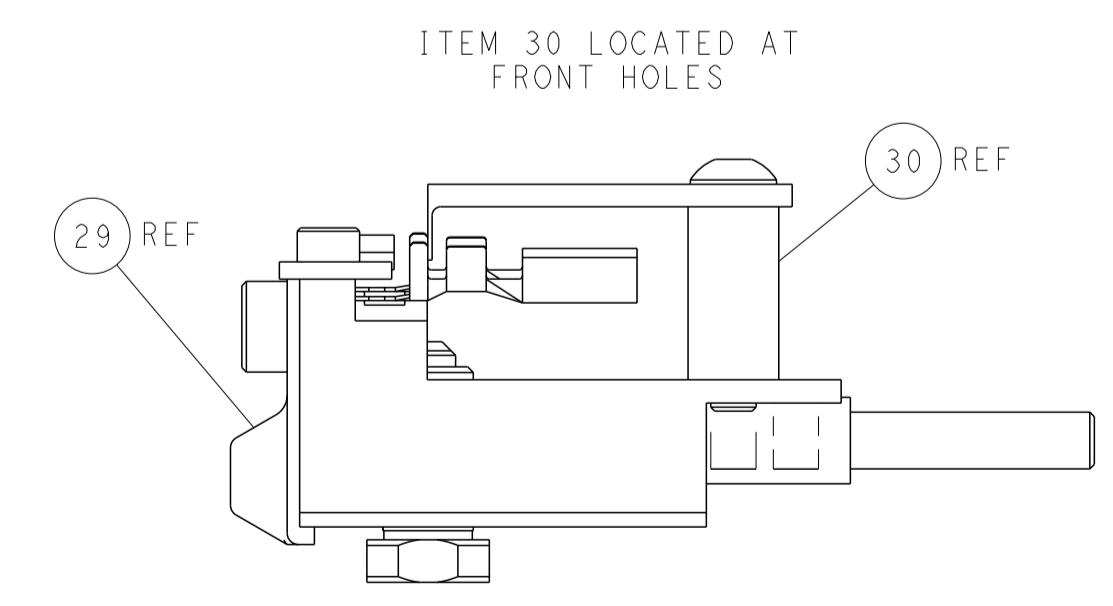

FEED TRACK POSITION
GUIDE BY INSULATION BARREL

CAM POSITION

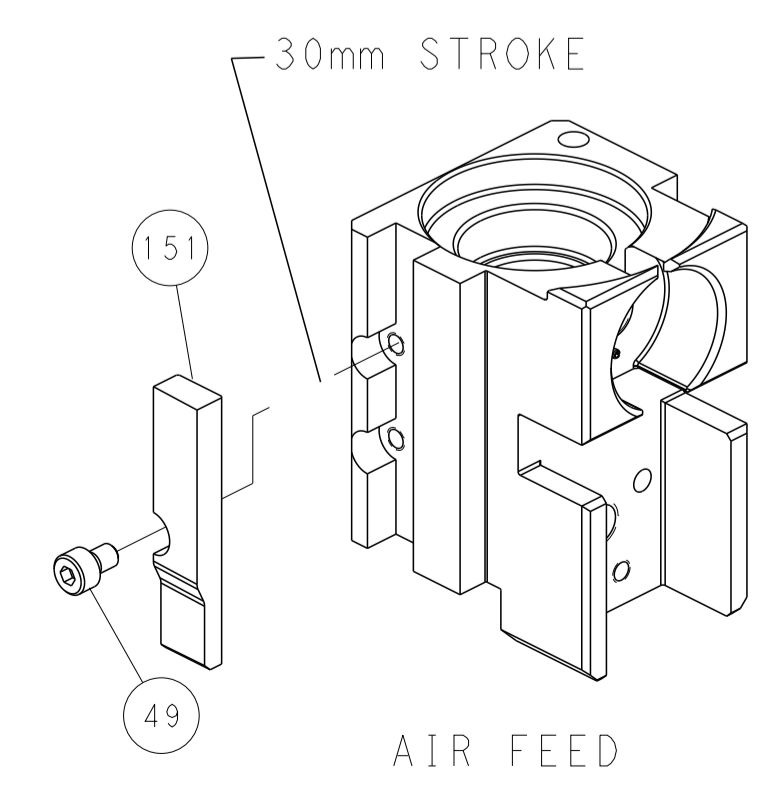

AIR FEED

PACIFIC VERSION
 Shown on sheets 3 of 4 & 4 of 4
 (Atlantic version shown on sheets 1 of 4 & 2 of 4)

DIMENSIONS:		TOLERANCES UNLESS OTHERWISE SPECIFIED:		DWG: X_ZHAO 16AUG2012		CHK: T_ELFIN 16AUG2012		APVD: S_XI 16AUG2012		NAME: Ocean Side Feed Applicator	
mm	0 PLC	±		SIZE	CAGE CODE	DRAWING NO	RESTRICTED TO				
	1 PLC	±		A1	00779	2151368					
	2 PLC	±		Customer Accessible Production Drawing		SCALE	1:2	SHEET	4	OF	4
	3 PLC	±						REV	B		
	4 PLC	±									
	ANGLES	±									
	FINISH	±									