

IRGI4060DPbF

INSULATED GATE BIPOLAR TRANSISTOR WITH ULTRAFAST SOFT RECOVERY DIODE

Features

- Low $V_{CE(on)}$ Trench IGBT Technology
- Low Switching Losses
- 5 μ s SCSOA
- Square RBSOA
- 100% of The Parts Tested for I_{LM} ①
- Positive $V_{CE(on)}$ Temperature Coefficient.
- Ultra Fast Soft Recovery Co-pak Diode
- Tighter Distribution of Parameters
- Lead-Free Package

Benefits

- High Efficiency in a Wide Range of Applications
- Suitable for a Wide Range of Switching Frequencies due to Low $V_{CE(ON)}$ and Low Switching Losses
- Rugged Transient Performance for Increased Reliability
- Excellent Current Sharing in Parallel Operation
- Low EMI

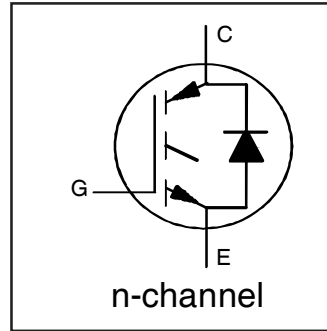

$V_{CES} = 600V$
$I_C = 7.5A, T_C = 100^\circ C$
$t_{sc} > 5\mu s, T_{jmax} = 150^\circ C$
$V_{CE(on) typ.} = 1.50V$

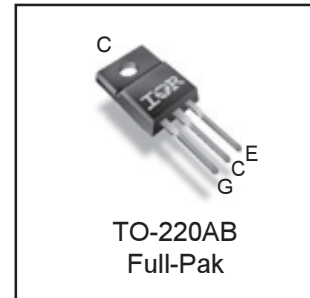

G	C	E
Gate	Collector	Emitter

Absolute Maximum Ratings

	Parameter	Max.	Units
V_{CES}	Collector-to-Emitter Breakdown Voltage	600	V
$I_C @ T_C = 25^\circ C$	Continuous Collector Current	14	A
$I_C @ T_C = 100^\circ C$	Continuous Collector Current	7.5	
I_{CM}	Pulse Collector Current, $V_{GE}=15V$	23	
I_{LM}	Clamped Inductive Load Current, $V_{GE}=20V$ ①	30	
$I_F @ T_C=25^\circ C$	Diode Continuous Forward Current	14	
$I_F @ T_C=100^\circ C$	Diode Continuous Forward Current	7.5	
I_{FM}	Diode Maximum Forward Current ②	30	
V_{GE}	Continuous Gate-to-Emitter Voltage	± 20	V
	Transient Gate-to-Emitter Voltage	± 30	
$P_D @ T_C = 25^\circ C$	Maximum Power Dissipation	37	W
$P_D @ T_C = 100^\circ C$	Maximum Power Dissipation	15	
T_J T_{STG}	Operating Junction and Storage Temperature Range	-55 to + 150	$^\circ C$
	Soldering Temperature, for 10 seconds	300 (0.063 in. (1.6mm) from case)	
	Mounting Torque, 6-32 or M3 Screw	10 lbf-in (1.1 N-m)	

Thermal Resistance

	Parameter	Min.	Typ.	Max.	Units
$R_{\theta JC}$	Junction-to-Case - IGBT ③	—	—	3.40	$^\circ C/W$
$R_{\theta JC}$	Junction-to-Case - Diode ③	—	—	6.10	
$R_{\theta CS}$	Case-to-Sink, flat, greased surface	—	0.5	—	
$R_{\theta JA}$	Junction-to-Ambient, typical socket mount ③	—	—	65	
Wt	Weight	—	2.0	—	g

Electrical Characteristics @ $T_J = 25^\circ\text{C}$ (unless otherwise specified)

	Parameter	Min.	Typ.	Max.	Units	Conditions
$V_{(BR)CES}$	Collector-to-Emitter Breakdown Voltage	600	—	—	V	$V_{GE} = 0V, I_C = 100 \mu A$ ④
$\Delta V_{(BR)CES}/\Delta T_J$	Temperature Coeff. of Breakdown Voltage	—	0.66	—	V/°C	$V_{GE} = 0V, I_C = 250 \mu A$ (-55 -150 °C) ④
$V_{CE(on)}$	Collector-to-Emitter Saturation Voltage	—	1.50	1.72		$I_C = 7.5A, V_{GE} = 15V, T_J = 25^\circ\text{C}$
		—	1.75	—	V	$I_C = 7.5A, V_{GE} = 15V, T_J = 125^\circ\text{C}$
		—	1.81	—		$I_C = 7.5A, V_{GE} = 15V, T_J = 150^\circ\text{C}$
$V_{GE(th)}$	Gate Threshold Voltage	4.0	—	6.5	V	$V_{CE} = V_{GE}, I_C = 250 \mu A$
$\Delta V_{GE(th)}/\Delta T_J$	Threshold Voltage temp. coefficient	—	-12	—	mV/°C	$V_{CE} = V_{GE}, I_C = 1.0mA$ (-55 -150 °C)
g_{fe}	Forward Transconductance	—	5	—	S	$V_{CE} = 50V, I_C = 7.5A, PW = 80\mu s$
I_{CES}	Collector-to-Emitter Leakage Current	—	1.0	25	μA	$V_{GE} = 0V, V_{CE} = 600V$
		—	400	—	μA	$V_{GE} = 0V, V_{CE} = 600V, T_J = 150^\circ\text{C}$
V_{FM}	Diode Forward Voltage Drop	—	2.18	3.00	V	$I_F = 7.5A$
		—	1.60	—		$I_F = 7.5A, T_J = 150^\circ\text{C}$
I_{GES}	Gate-to-Emitter Leakage Current	—	—	± 100	nA	$V_{GE} = \pm 20 V$

Switching Characteristics @ $T_J = 25^\circ\text{C}$ (unless otherwise specified)

	Parameter	Min.	Typ.	Max.	Units	Conditions
Q_g	Total Gate Charge (turn-on)	—	19	29	nC	$I_C = 7.5A$ $V_{CC} = 400V$ $V_{GE} = 15V$
Q_{ge}	Gate-to-Emitter Charge (turn-on)	—	4.3	6		
Q_{gc}	Gate-to-Collector Charge (turn-on)	—	8.3	12		
E_{on}	Turn-On Switching Loss	—	47	89	μJ	$I_C = 7.5A, V_{CC} = 400V, V_{GE} = 15V$ $R_G = 47\Omega, L = 1mH, L_S = 150nH, T_J = 25^\circ\text{C}$ Energy losses include tail and diode reverse recovery
E_{off}	Turn-Off Switching Loss	—	141	248		
E_{total}	Total Switching Loss	—	188	337		
$t_{d(on)}$	Turn-On delay time	—	29	38	ns	$I_C = 7.5A, V_{CC} = 400V$ $R_G = 47\Omega, L = 1mH, L_S = 150nH$ $T_J = 25^\circ\text{C}$
t_r	Rise time	—	16	25		
$t_{d(off)}$	Turn-Off delay time	—	101	112		
t_f	Fall time	—	28	37		
E_{on}	Turn-On Switching Loss	—	107	—	μJ	$I_C = 7.5A, V_{CC} = 400V, V_{GE} = 15V$ $R_G = 47\Omega, L = 1mH, L_S = 150nH, T_J = 150^\circ\text{C}$ Energy losses include tail and diode reverse recovery
E_{off}	Turn-Off Switching Loss	—	196	—		
E_{total}	Total Switching Loss	—	304	—		
$t_{d(on)}$	Turn-On delay time	—	28	—	ns	$I_C = 7.5A, V_{CC} = 400V$ $R_G = 47\Omega, L = 1mH, L_S = 150nH$ $T_J = 150^\circ\text{C}$
t_r	Rise time	—	17	—		
$t_{d(off)}$	Turn-Off delay time	—	118	—		
t_f	Fall time	—	53	—		
C_{ies}	Input Capacitance	—	537	—	pF	$V_{GE} = 0V$ $V_{CC} = 30V$ $f = 1Mhz$
C_{oes}	Output Capacitance	—	47	—		
C_{res}	Reverse Transfer Capacitance	—	16	—		
RBSOA	Reverse Bias Safe Operating Area	FULL SQUARE				$T_J = 150^\circ\text{C}, I_C = 30A$ $V_{CC} = 480V, V_p = 600V$ $R_G = 47\Omega, V_{GE} = +20V$ to 0V
SCSOA	Short Circuit Safe Operating Area	5	—	—	μs	$V_{CC} = 400V, V_p = 600V$ $R_G = 47\Omega, V_{GE} = +15V$ to 0V
E_{rec}	Reverse recovery energy of the diode	—	102	—	μJ	$T_J = 150^\circ\text{C}$
t_{rr}	Diode Reverse recovery time	—	73	—	ns	$V_{CC} = 400V, I_F = 7.5A$
I_{rr}	Peak Reverse Recovery Current	—	11	—	A	$V_{GE} = 15V, R_G = 47\Omega, L = 1mH, L_S = 150nH$

Notes:

- ① $V_{CC} = 80\% (V_{CES}), V_{GE} = 20V, L = 28 \mu H, R_G = 47 \Omega$
- ② Pulse width limited by max. junction temperature.
- ③ R_θ is measured at T_J approximately 90°C
- ④ Refer to AN-1086 for guidelines for measuring $V_{(BR)CES}$ safely

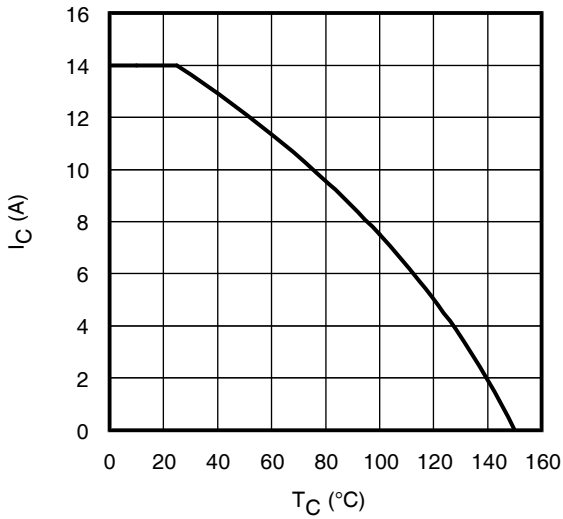

Fig. 1 - Maximum DC Collector Current vs. Case Temperature

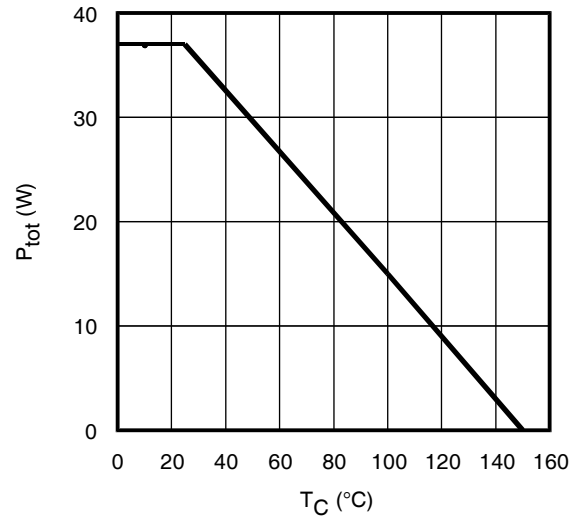

Fig. 2 - Power Dissipation vs. Case Temperature

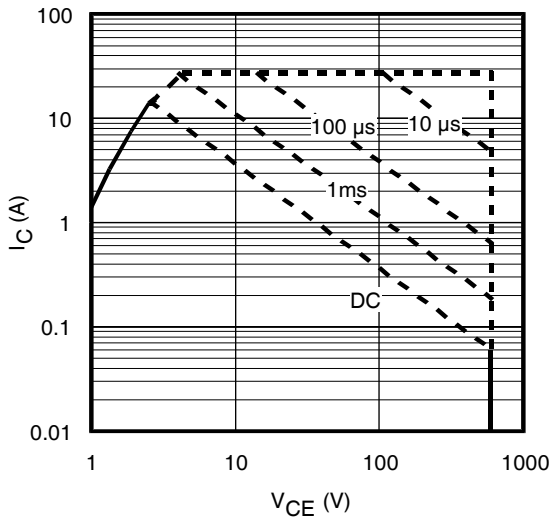

Fig. 3 - Forward SOA,
TC = 25°C; TJ ≤ 150°C

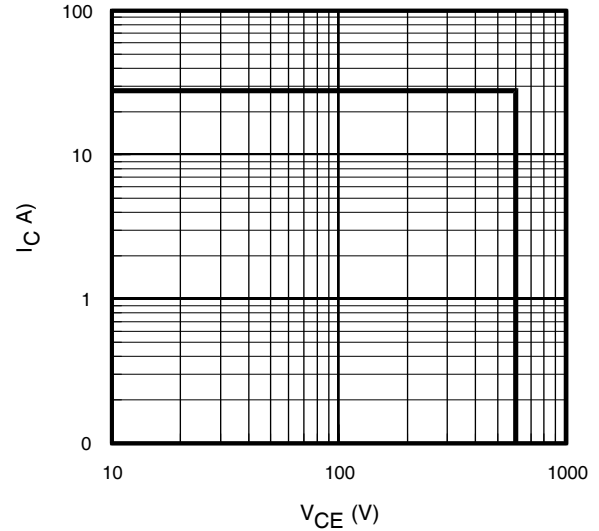

Fig. 4 - Reverse Bias SOA
TJ = 150°C; VCE = 15V

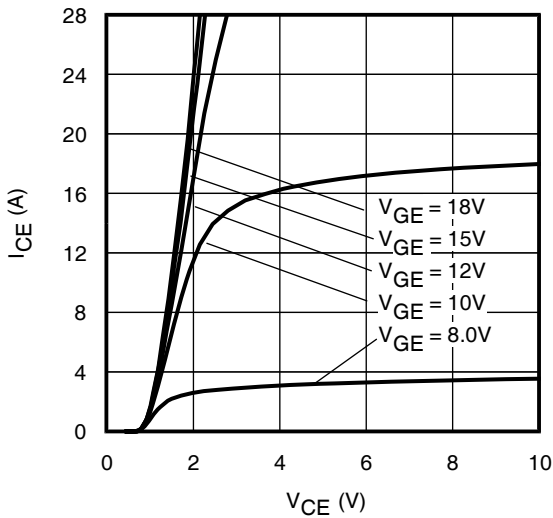

Fig. 5 - Typ. IGBT Output Characteristics
TJ = -40°C; tp < 60µs

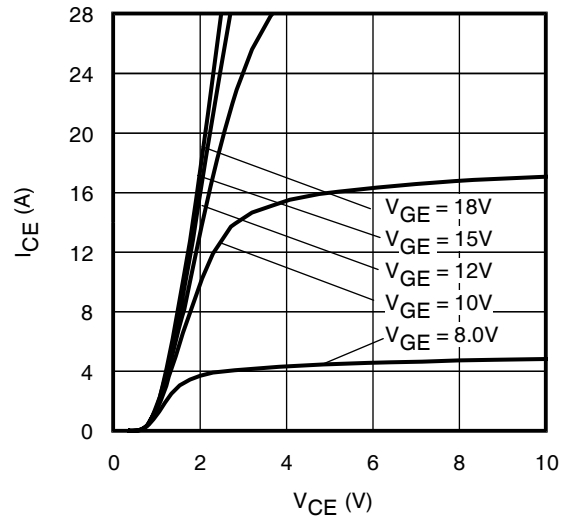

Fig. 6 - Typ. IGBT Output Characteristics
TJ = 25°C; tp < 60µs

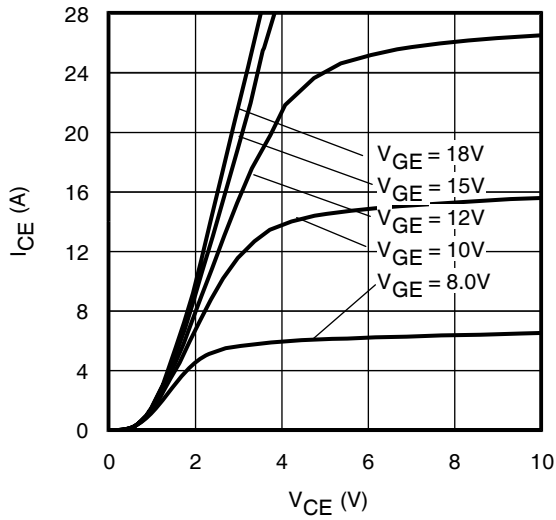

Fig. 7 - Typ. IGBT Output Characteristics
 $T_J = 150^\circ\text{C}$; $t_p < 60\mu\text{s}$

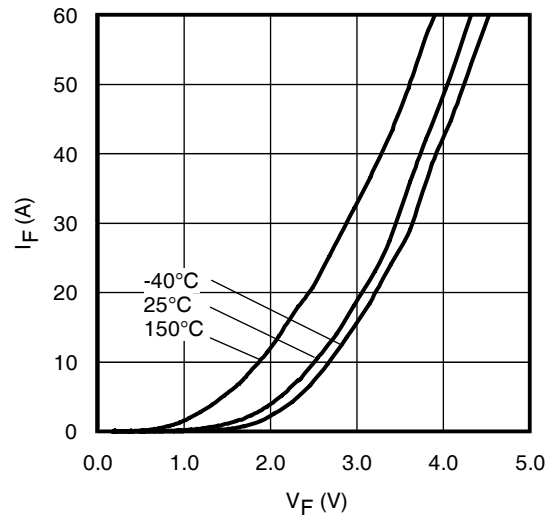

Fig. 8 - Typ. Diode Forward Characteristics
 $t_p < 60\mu\text{s}$

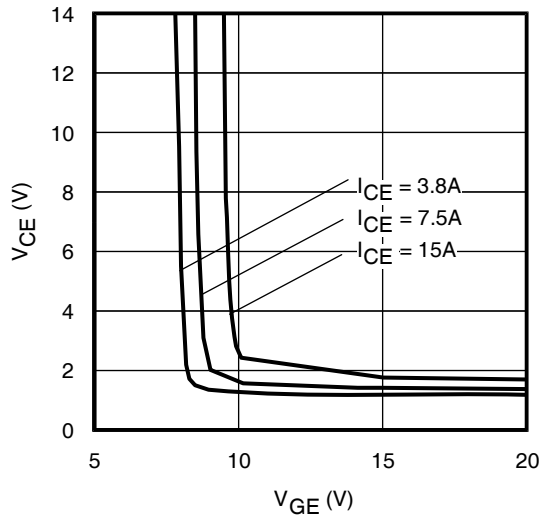

Fig. 9 - Typical V_{CE} vs. V_{GE}
 $T_J = -40^\circ\text{C}$

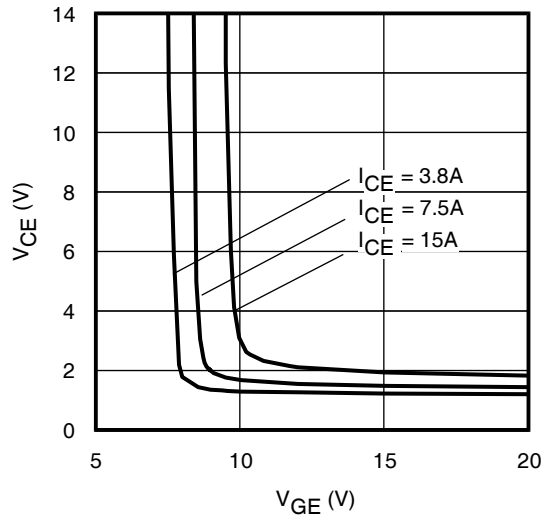

Fig. 10 - Typical V_{CE} vs. V_{GE}
 $T_J = 25^\circ\text{C}$

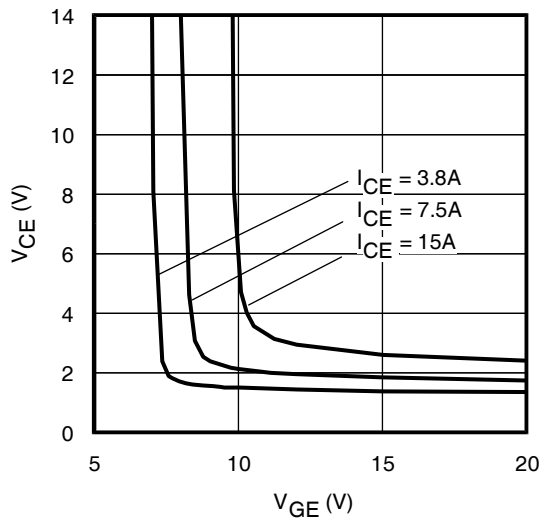

Fig. 11 - Typical V_{CE} vs. V_{GE}
 $T_J = 150^\circ\text{C}$

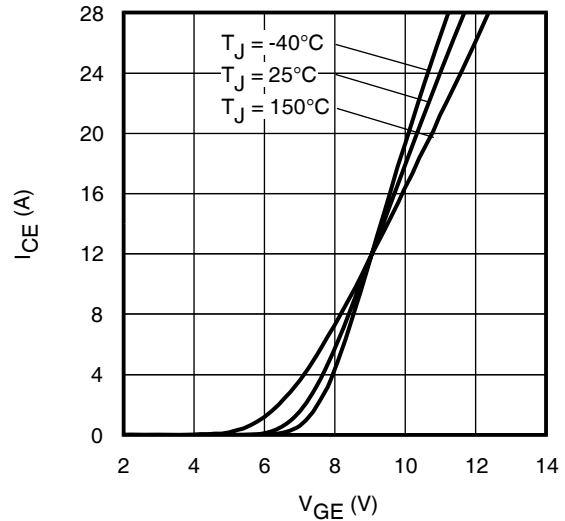

Fig. 12 - Typ. Transfer Characteristics
 $V_{CE} = 50\text{V}$; $t_p < 60\mu\text{s}$

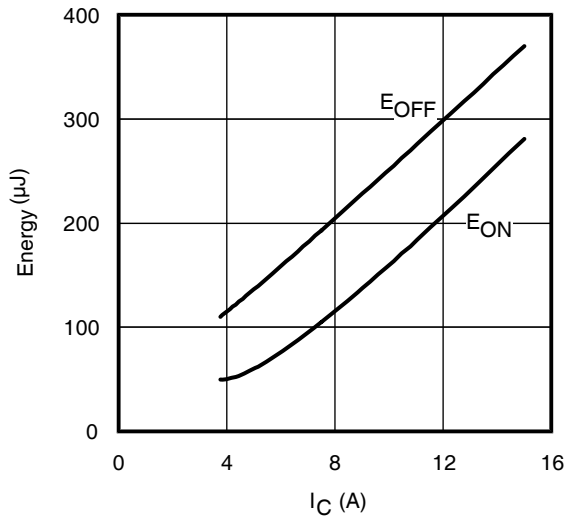

Fig. 13 - Typ. Energy Loss vs. I_C
 $T_J = 150^\circ\text{C}$; $L = 1\text{mH}$; $V_{CE} = 400\text{V}$; $R_G = 47\Omega$; $V_{GE} = 15\text{V}$.

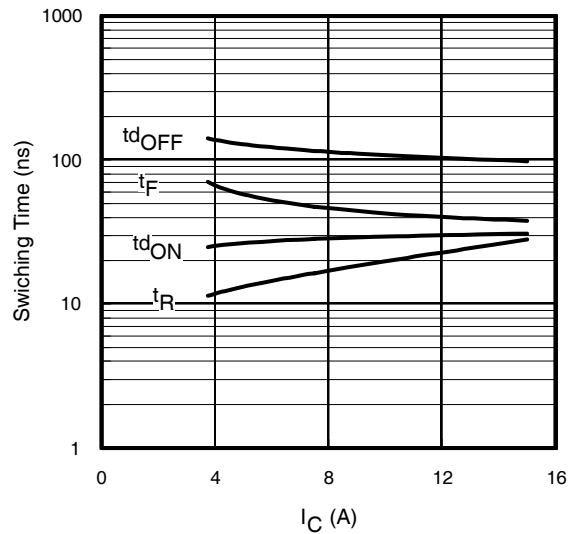

Fig. 14 - Typ. Switching Time vs. I_C
 $T_J = 150^\circ\text{C}$; $L = 1\text{mH}$; $V_{CE} = 400\text{V}$
 $R_G = 47\Omega$; $V_{GE} = 15\text{V}$

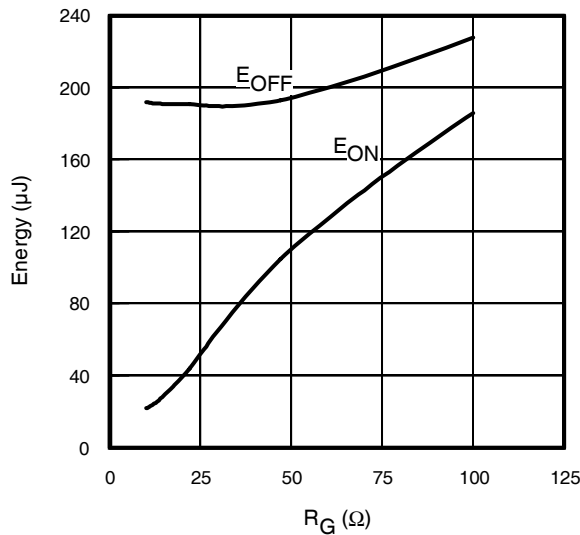

Fig. 15 - Typ. Energy Loss vs. R_G
 $T_J = 150^\circ\text{C}$; $L = 1\text{mH}$; $V_{CE} = 400\text{V}$; $I_{CE} = 7.5\text{A}$; $V_{GE} = 15\text{V}$

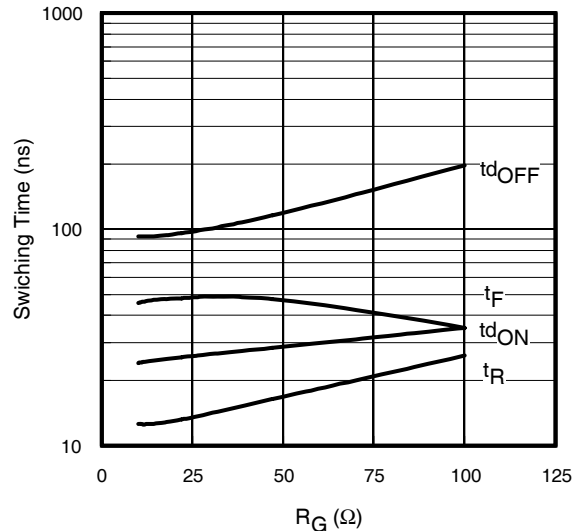

Fig. 16 - Typ. Switching Time vs. R_G
 $T_J = 150^\circ\text{C}$; $L = 1\text{mH}$; $V_{CE} = 400\text{V}$
 $I_{CE} = 7.5\text{A}$; $V_{GE} = 15\text{V}$

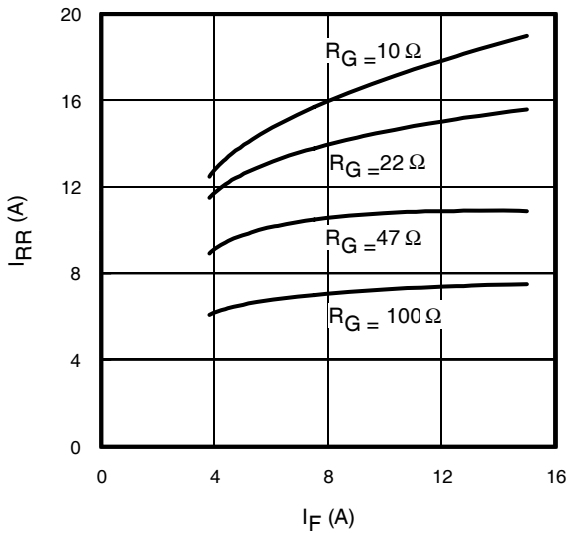

Fig. 17 - Typical Diode I_{RR} vs. I_F
 $T_J = 150^\circ\text{C}$

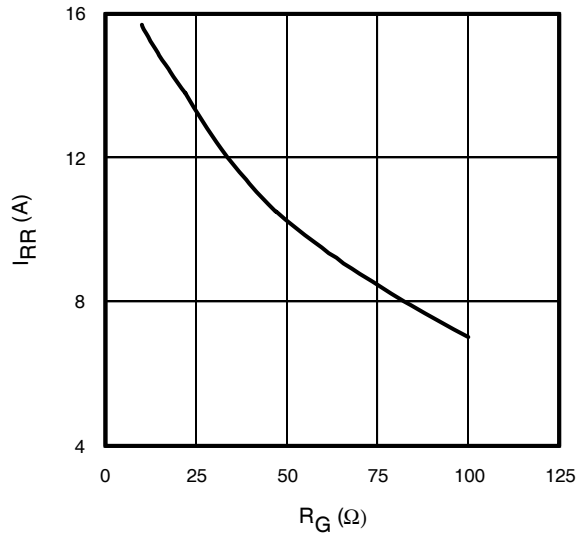

Fig. 18 - Typical Diode I_{RR} vs. R_G
 $T_J = 150^\circ\text{C}$; $I_F = 7.5\text{A}$

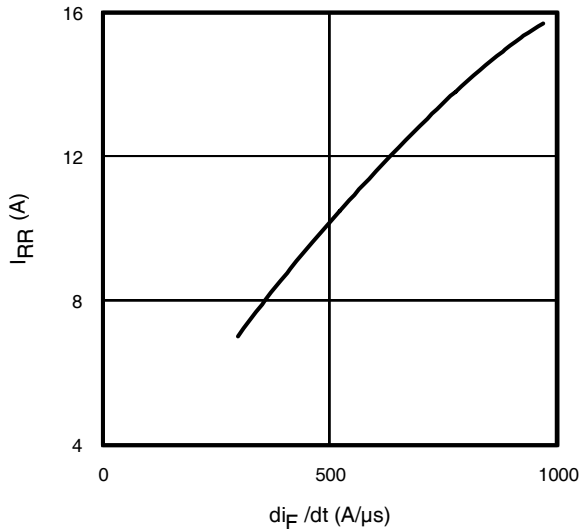

Fig. 19 - Typical Diode I_{RR} vs. di_F/dt
 $V_{CC}=400V$; $V_{GE}=15V$;
 $I_{CE}=7.5A$; $T_J=150^{\circ}C$

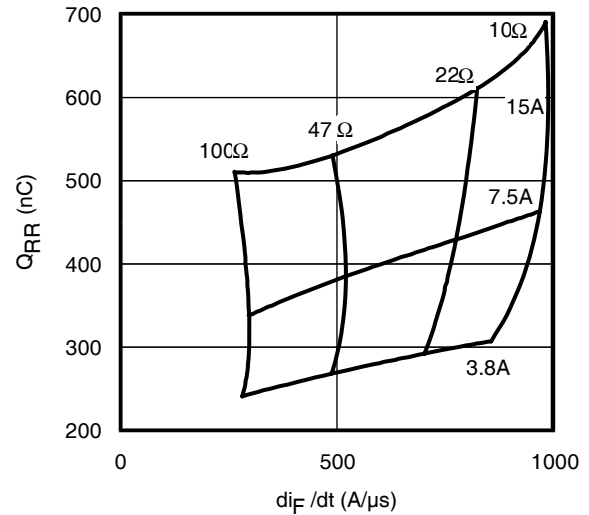

Fig. 20 - Typical Diode Q_{RR}
 $V_{CC}=400V$; $V_{GE}=15V$; $T_J=150^{\circ}C$

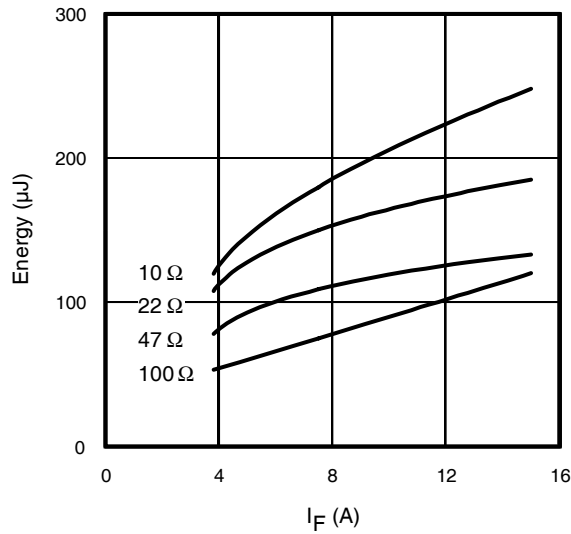

Fig. 21 - Typical Diode E_{RR} vs. I_F
 $T_J=150^{\circ}C$

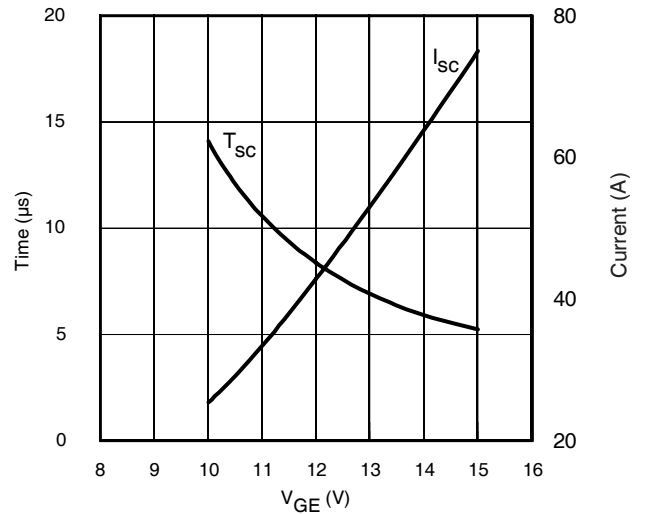

Fig. 22 - Typ. V_{GE} vs Short Circuit Time
 $V_{CC}=400V$, $T_C=25^{\circ}C$

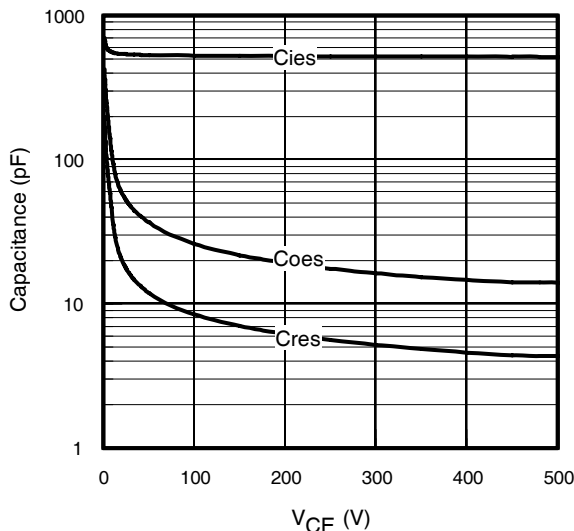

Fig. 23 - Typ. Capacitance vs. V_{CE}
 $V_{GE}=0V$; $f=1MHz$

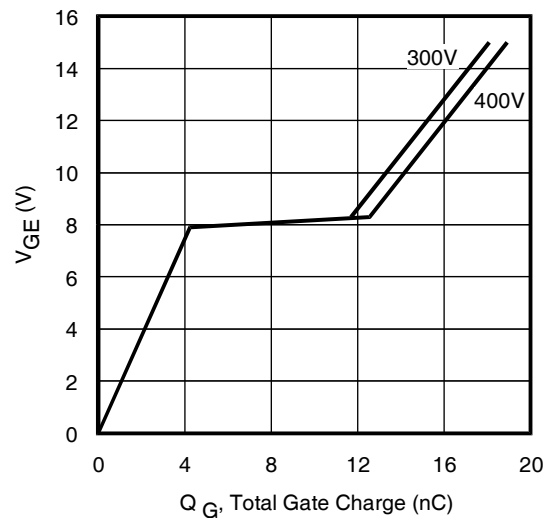

Fig. 24 - Typical Gate Charge vs. V_{GE}
 $I_{CE}=7.5A$, $L=600\mu H$

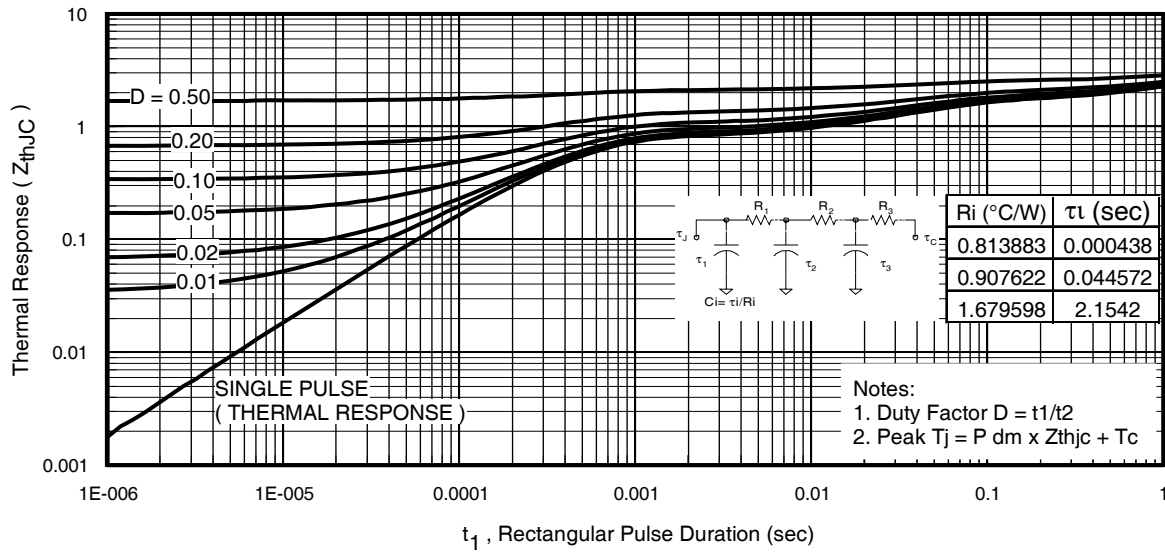

Fig 25. Maximum Transient Thermal Impedance, Junction-to-Case (IGBT)

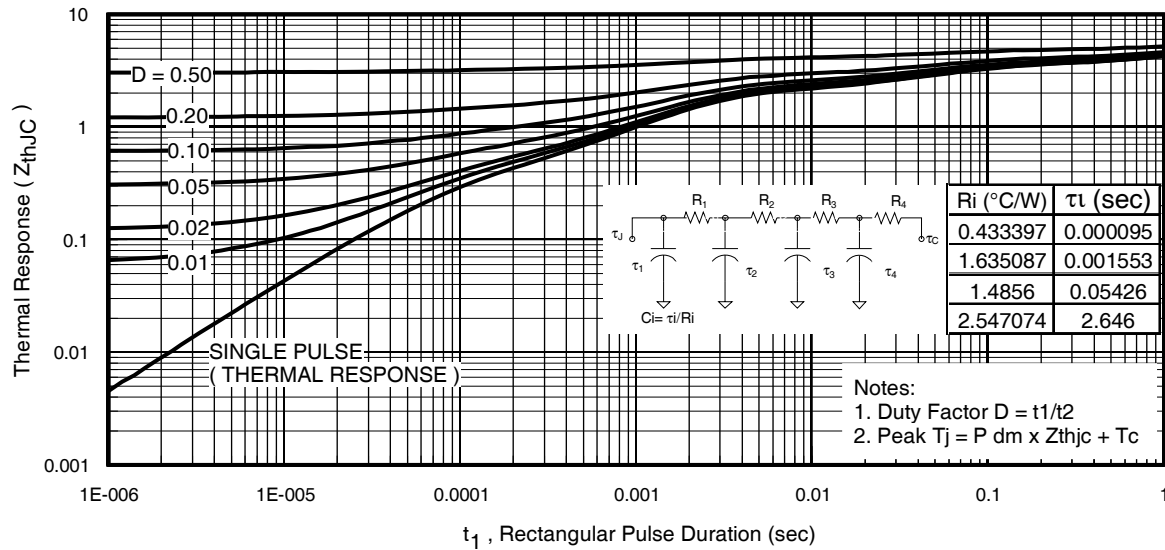

Fig. 26. Maximum Transient Thermal Impedance, Junction-to-Case (DIODE)

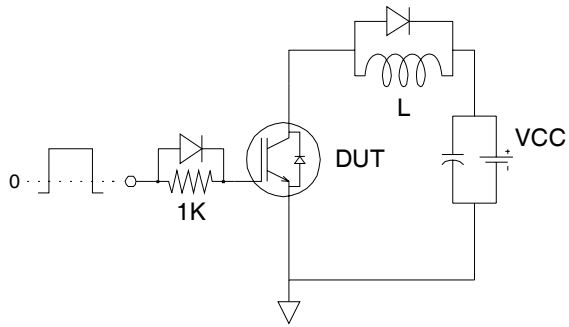

Fig.C.T.1 - Gate Charge Circuit (turn-off)

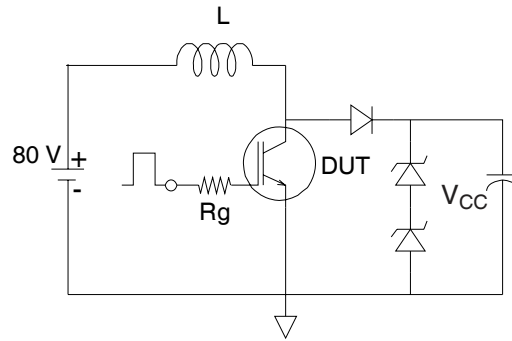

Fig.C.T.2 - RBSOA Circuit

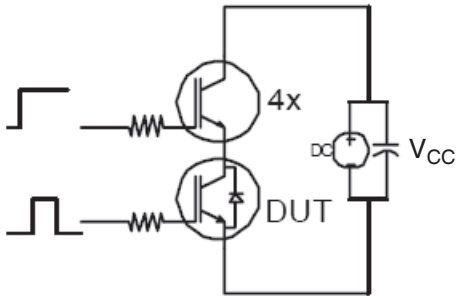

Fig.C.T.3 - S.C.SOA Circuit

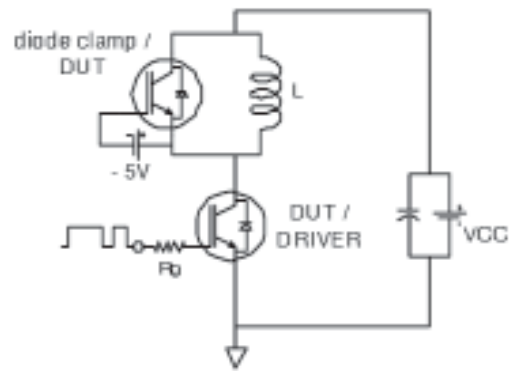

Fig.C.T.4 - Switching Loss Circuit

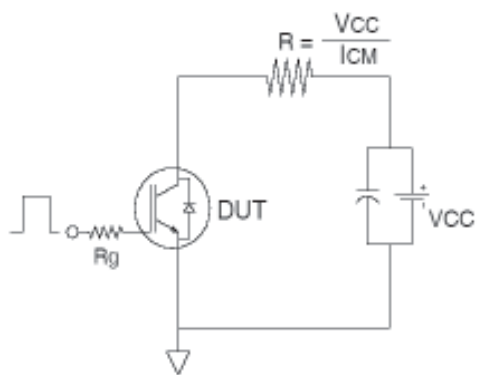

Fig.C.T.5 - Resistive Load Circuit

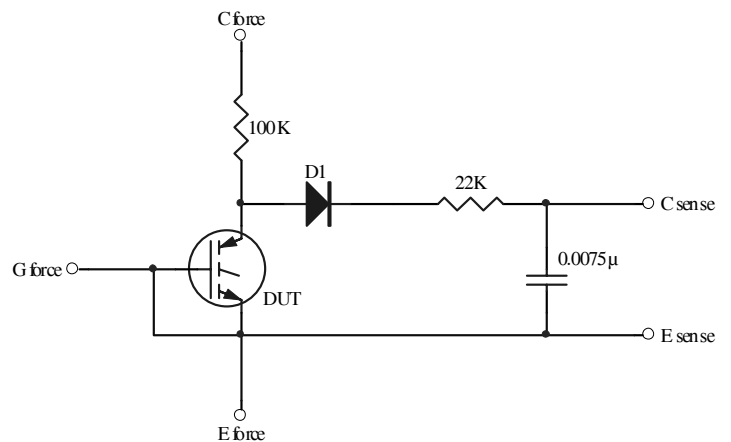

Fig.C.T.6 - Typical Filter Circuit for $V_{(BR)CES}$ Measurement

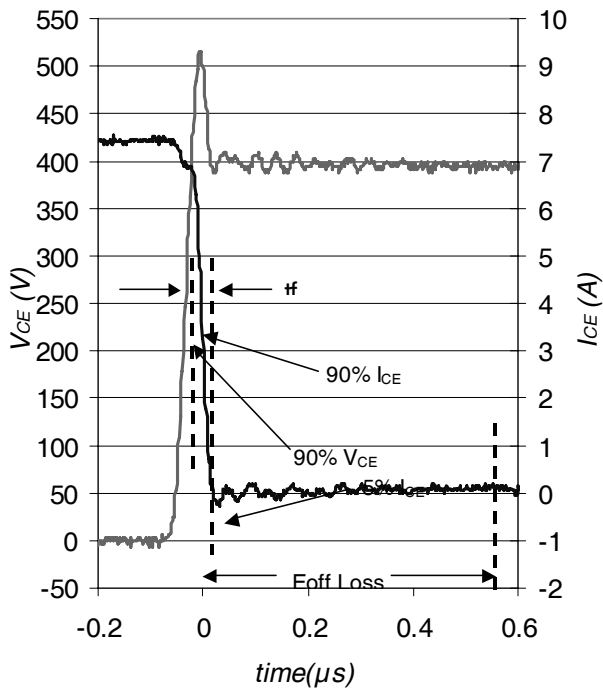

Fig. WF1 - Typ. Turn-off Loss Waveform
@ $T_J = 150^\circ\text{C}$ using Fig. CT.4

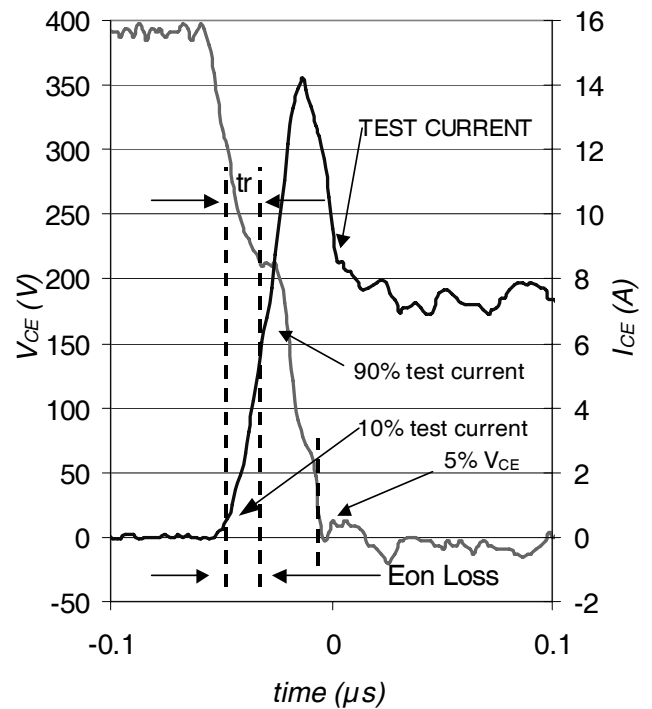
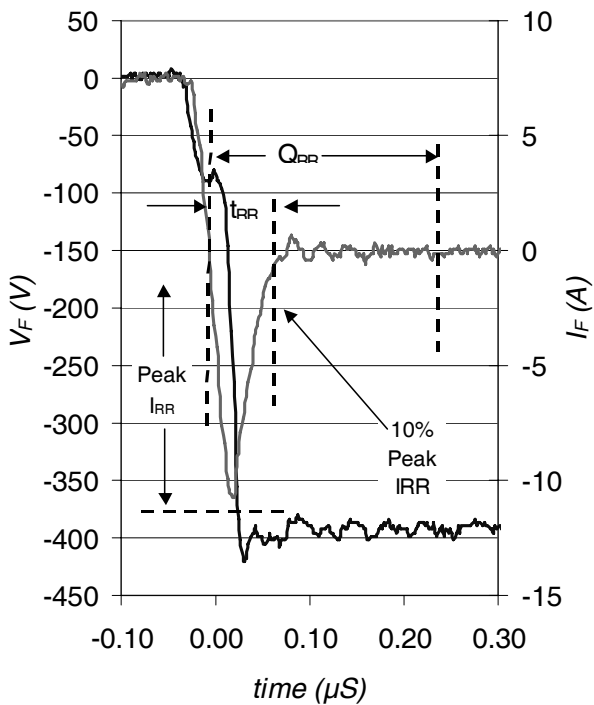
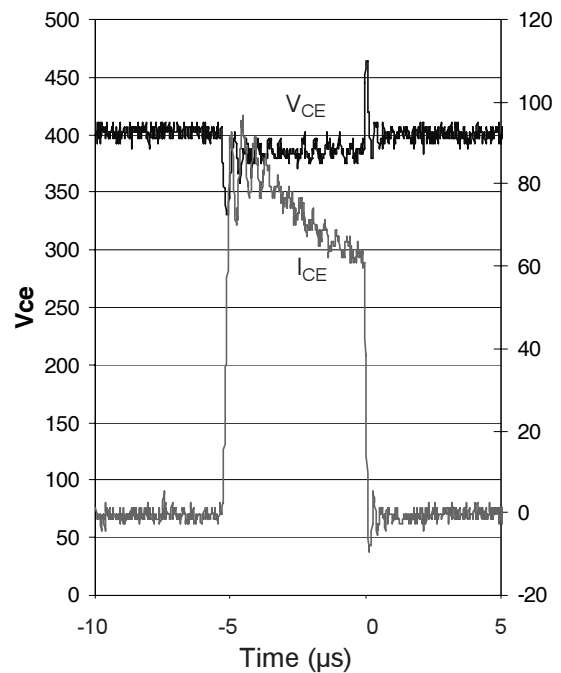

Fig. WF2 - Typ. Turn-on Loss Waveform
@ $T_J = 150^\circ\text{C}$ using Fig. CT.4



WF.3- Typ. Reverse Recovery Waveform
@ $T_J = 150^\circ\text{C}$ using CT.4



WF.4- Typ. Short Circuit Waveform
@ $T_J = 25^\circ\text{C}$ using CT.3

TO-220 Full-Pak Package Outline

Dimensions are shown in millimeters (inches)

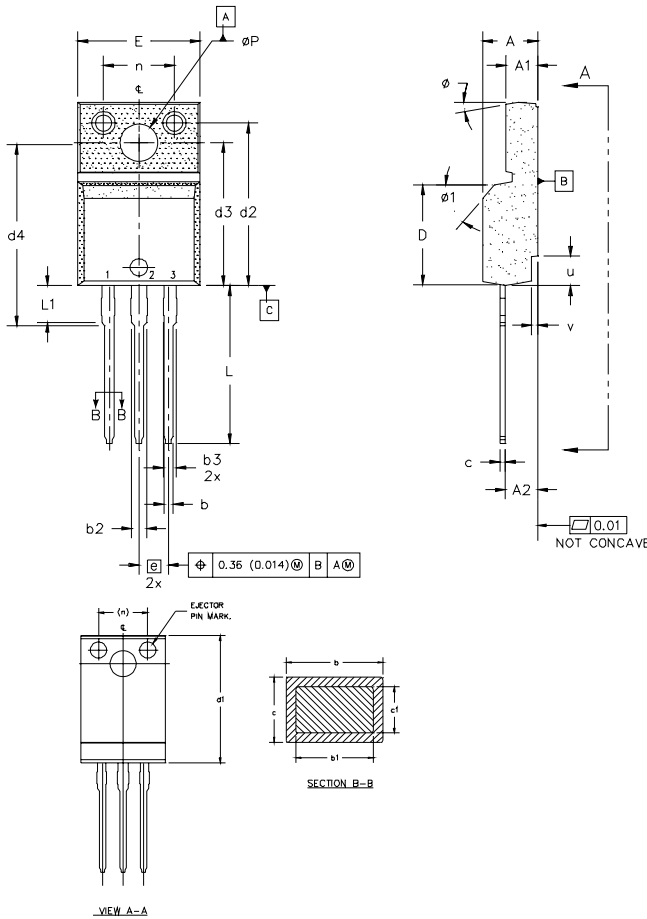

- NOTES:
- 1.0 DIMENSIONING AND TOLERANCING PER ASME Y14.5 M- 1994.
 - 2.0 DIMENSIONS ARE SHOWN IN MILLIMETERS [INCHES].
 - 3.0 LEAD DIMENSION AND FINISH UNCONTROLLED IN L1.
 - 4.0 DIMENSION D & E DO NOT INCLUDE MOLD FLASH. MOLD FLASH SHALL NOT EXCEED 0.008" (0.127) PER SIDE, THESE DIMENSIONS ARE MEASURED AT THE OUTERMOST EXTREMES OF THE PLASTIC BODY.
 - 5.0 DIMENSION b1 APPLY TO BASE METAL ONLY.
 - 6.0 STEP OPTIONAL ON PLASTIC BODY DEFINED BY DIMENSIONS u & v.
 - 7.0 CONTROLLING DIMENSION : INCHES.

SYMBOL	DIMENSIONS				NOTES
	MILLIMETERS		INCHES		
	MIN.	MAX.	MIN.	MAX.	
A	4.57	4.83	0.180	0.190	5
A1	2.57	2.83	0.101	0.114	
A2	2.51	2.85	0.099	0.112	
b	0.622	0.89	0.024	0.035	
b1	0.622	0.838	0.024	0.033	
b2	1.229	1.400	0.048	0.055	
b3	1.229	1.400	0.048	0.055	
c	0.440	0.629	0.017	0.025	4
c1	0.440	0.584	0.017	0.023	
D	8.65	9.80	0.341	0.386	
d1	15.80	16.12	0.622	0.635	
d2	13.97	14.22	0.550	0.560	
d3	12.30	12.92	0.484	0.509	
d4	8.64	9.91	0.340	0.390	
E	10.36	10.63	0.408	0.419	4
e	2.54 BSC		0.100 BSC		
L	13.20	13.73	0.520	0.541	3
L1	3.10	3.50	0.122	0.138	
n	6.05	6.15	0.238	0.242	6
phi P	3.05	3.45	0.120	0.136	
u	2.40	2.50	0.094	0.098	6
v	0.40	0.50	0.016	0.020	
phi	3°	7°	3°	7°	6
phi 1		45°		45°	

LEAD ASSIGNMENTS

HEXFET

- 1.- GATE
- 2.- DRAIN
- 3.- SOURCE

IGBTs, CoPACK

- 1.- GATE
- 2.- COLLECTOR
- 3.- EMITTER

TO-220 Full-Pak Part Marking Information

EXAMPLE: THIS IS AN IRF1840G
WITH ASSEMBLY
LOT CODE 3432
ASSEMBLED ON WW 24, 2001
IN THE ASSEMBLY LINE "K"

Note: "P" in assembly line position
indicates "Lead-Free"

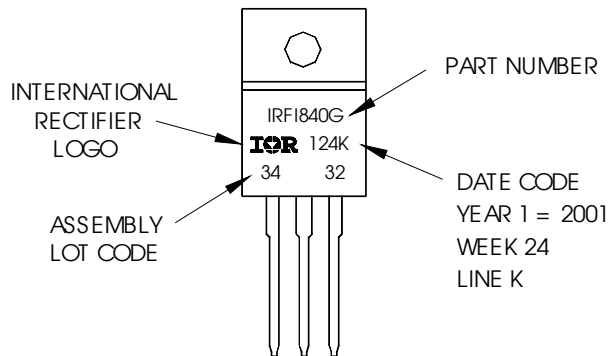

TO-220 Full-Pak package is not recommended for Surface Mount Application.

Note: For the most current drawing please refer to IR website at: <http://www.irf.com/package/>

Data and specifications subject to change without notice.
This product has been designed and qualified for Industrial market.
Qualification Standards can be found on IR's Web site.