

THIS DRAWING AND THE SUBJECT MATTER SHOWN THEREON ARE CONFIDENTIAL AND THE PROPERTY OF BEL/STEWART/TRP CONNECTOR AND SHALL NOT BE REPRODUCED, COPIED, OR USED IN ANY MANNER WITHOUT THE WRITTEN CONSENT OF TRP CONNECTOR.

PRODUCT MAY BE PROTECTED BY ONE OR MORE OF THE FOLLOWING US PATENTS:  
 5736910 5939955 6425781 6428361 6554638 6840817 7123117  
 7429195 7717749 7808751 6217391 6149050 7924130

REVISIONS				
P	LTN	DESCRIPTION	DATE	APPD
2		SEE LAST SHEET	14JAN2015	RL TY

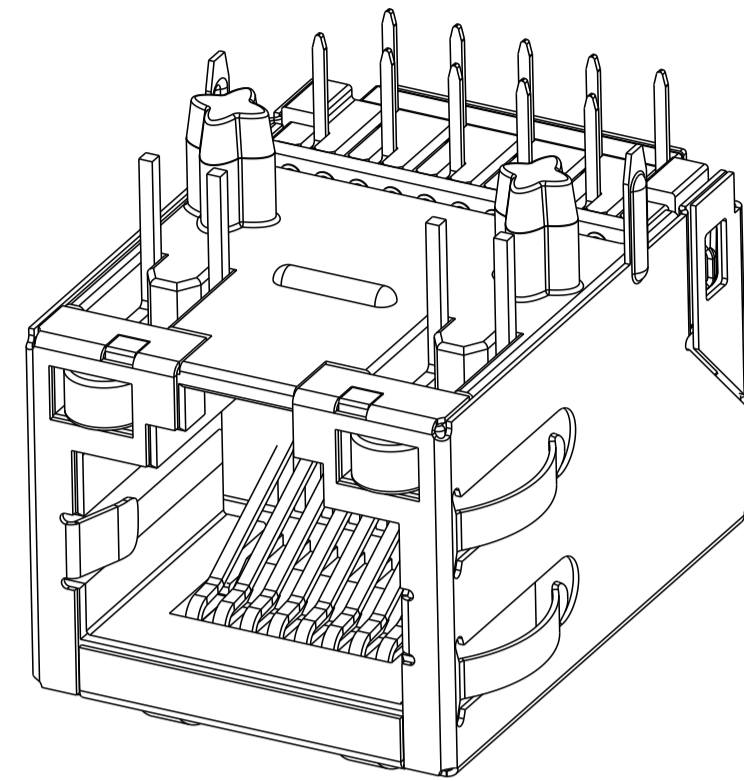
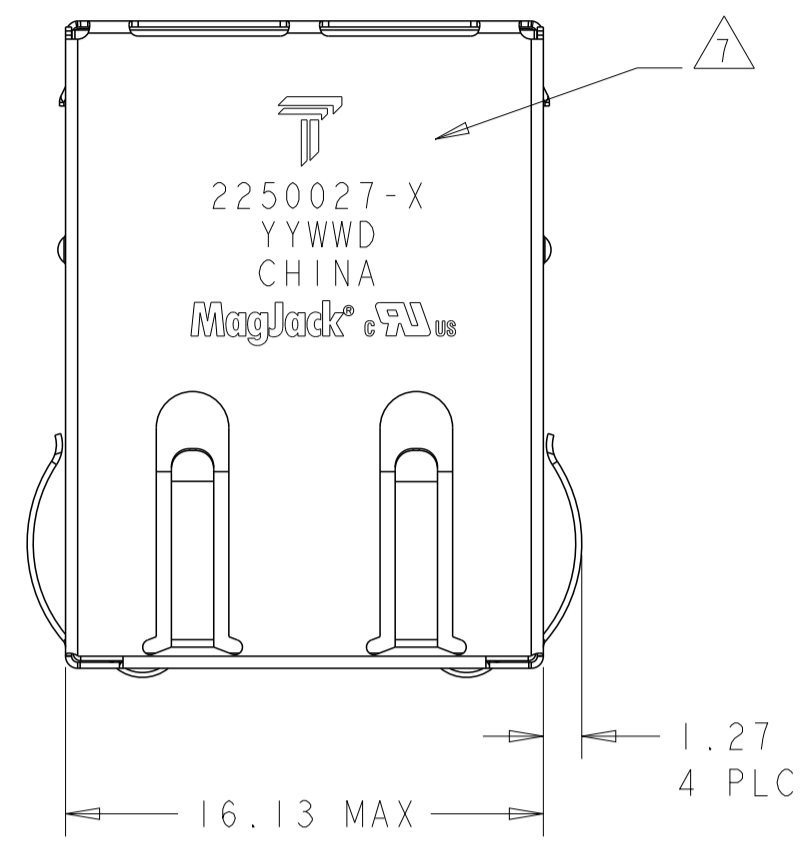

1. MATERIALS
- HOUSING: THERMOPLASTIC, FLAMMABILITY RATING UL 94V-0.
  - SHIELD: BRASS 0.20mm THICK, PREPLATED WITH 0.76um MIN SEMI-BRIGHT NICKEL. SOLDER TABS POST DIPPED WITH 2.54um MIN SAC SOLDER.
  - CONTACTS: PHOSPHOR BRONZE 0.46mm X 0.30mm, PHOSPHOR BRONZE, 1.27um MIN NICKEL UNDERPLATE, WITH 1.27um MIN GOLD PLATING AT MATING INTERFACE AND 2.54um MIN MATTE TIN ON SOLDER TAILS.
  - SOLDER TAILS: 0.25mm THICK, PHOSPHOR BRONZE, 1.27um MIN OVERALL NICKEL UNDERPLATE, 3um TIN PLATE
  - LIGHT EMITTING DIODE (LED): DIFFUSED EPOXY LENS, 0.5mm X 0.5mm CARBON STEEL WIREFRAME LEADS PREPLATED WITH 2.03um MIN. SILVER PLATE OVER 1.02um MIN. NICKEL OVER 1.02um MIN. COPPER UNDERPLATE; LEADS POST-PLATED WITH 3.05um MIN. MATTE TIN AND/OR SAC SOLDER DIP OR PURE TIN SOLDER DIP

2 RJ45 JACK CAVITY CONFORMS TO FCC RULES AND REGULATIONS PART 68 SUB PART F.

- 3 MAGNETICS
- APPLICATION: 10/100/1000 BASE-T
  - IMPEDANCE: 100 OHMS
  - TURNS RATIO (CHIP:CABLE): 1:1 ALL FOUR PAIRS
  - OPEN CIRCUIT INDUCTANCE (OCL): 350uH MIN. @100kHz, 0.1VRMS, 8mADC BIAS FROM 0°C TO 70°C, ALL FOUR PAIRS
  - ALL FOUR PAIRS BI-DIRECTIONAL
  - PERFORMANCE @ 25°C:
    - INSERTION LOSS (IL): 1.1dB MAX. FROM 0.5MHz TO 100MHz
    - RETURN LOSS (RL): 18dB MIN FROM 0.5MHz TO 40MHz
    - 12-20LOG(f/80)dB MIN. FROM 40.1MHz TO 100MHz
    - CROSSTALK ATTENUATION: 35dB MIN. FROM 0.5MHz TO 40MHz
    - 33-20LOG(f/50)dB MIN. FROM 40.1MHz TO 100MHz
    - COMMON MODE REJECTION RATIO (CMRR): 30dB MIN. FROM 0.5MHz TO 100MHz
    - ISOLATION VOLTAGE: 2250VDC FOR 60 SECONDS WITH A RISE TIME OF 500 V/SEC

4. OPERATING TEMPERATURE: FROM 0°C TO +70°C.

5 INDICATED MAGNETIC CONNECTIONS ARE SYMMETRICAL TO SUPPORT AUTO-MDI/MDIX.

6 THE 250 OHM LED RESISTORS ARE OPTIONAL, PLEASE SEE CHART FOR PRESENCE OR ABSENCE OF RESISTORS. IF LEDS WITHOUT 250 OHM RESISTORS. LEDS ARE DRIVEN WITH CONSTANT CURRENT AT APPROX 20mA

LED COLOR: DOMINATE WAVELENGTH (λD): GREEN 568 nm TYP. AT IF = 20mA  
 FORWARD VOLTAGE (VF): GREEN 2.2V TYP. at IF = 20mA  
 DOMINATE WAVELENGTH (λD): YELLOW 588 nm TYP. AT IF = 20mA  
 FORWARD VOLTAGE (VF): YELLOW 2.1V TYP. at IF = 20mA

IF LEDS WITH BUIL-IN 250 OHM RESISTORS. LEDS ARE DRIVEN WITH 5V VOLTAGE AND THE MAX OPERATING CURRENT IS 20mA

LED COLOR: DOMINATE WAVELENGTH (λD): GREEN 568 nm TYP @ VF=5V  
 FORWARD CURRENT (IF): GREEN 12mA TYP @ VF = 5V  
 DOMINATE WAVELENGTH (λD): YELLOW 588 nm TYP @ VF=5V  
 FORWARD CURRENT (IF): YELLOW 13mA TYP @ VF = 5V

7 TRP CONNECTOR LOGO, PART NUMBER, DATE CODE, COUNTRY OF ORIGIN AND AGENCY APPROVAL MARKING IN APPROXIMATE LOCATION SHOWN.

8. THESE PARTS ARE RECOMMENDED FOR WAVE SOLDERING PROCESS, PREHEAT TEMPERATURE IS 120°C TO 160°C, 120 SECONDS TO 180 SECONDS, PEAK WAVE SOLDERING TEMPERATURE IS 260°C MAX, 10 SECONDS MAX.

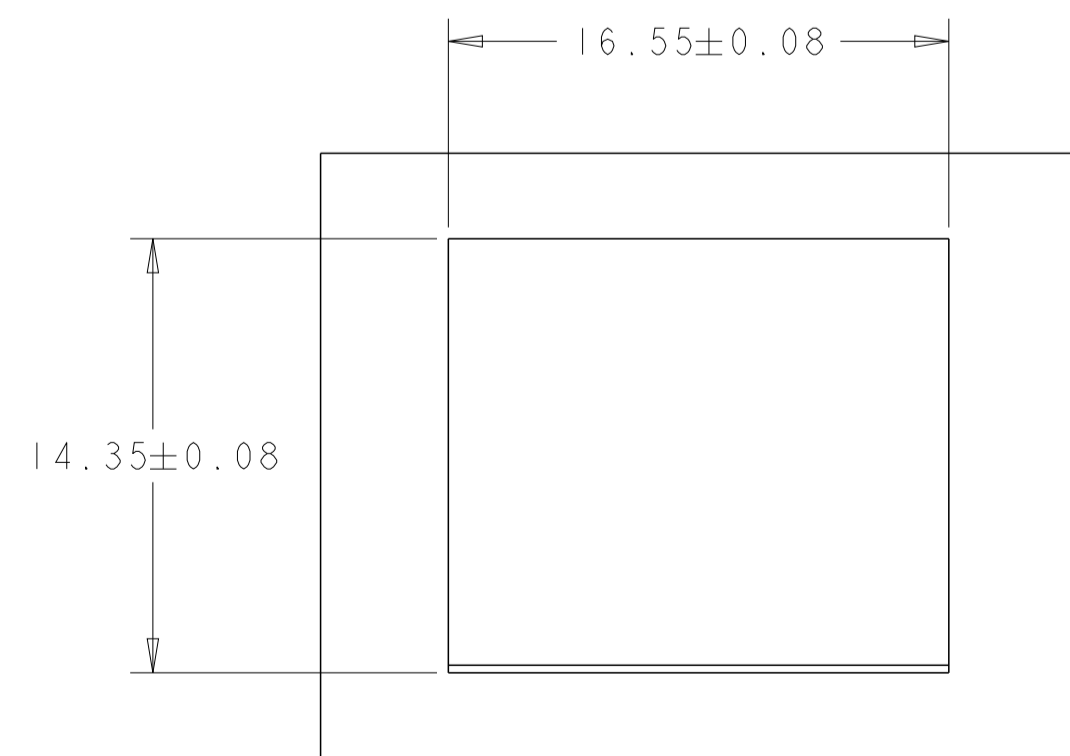
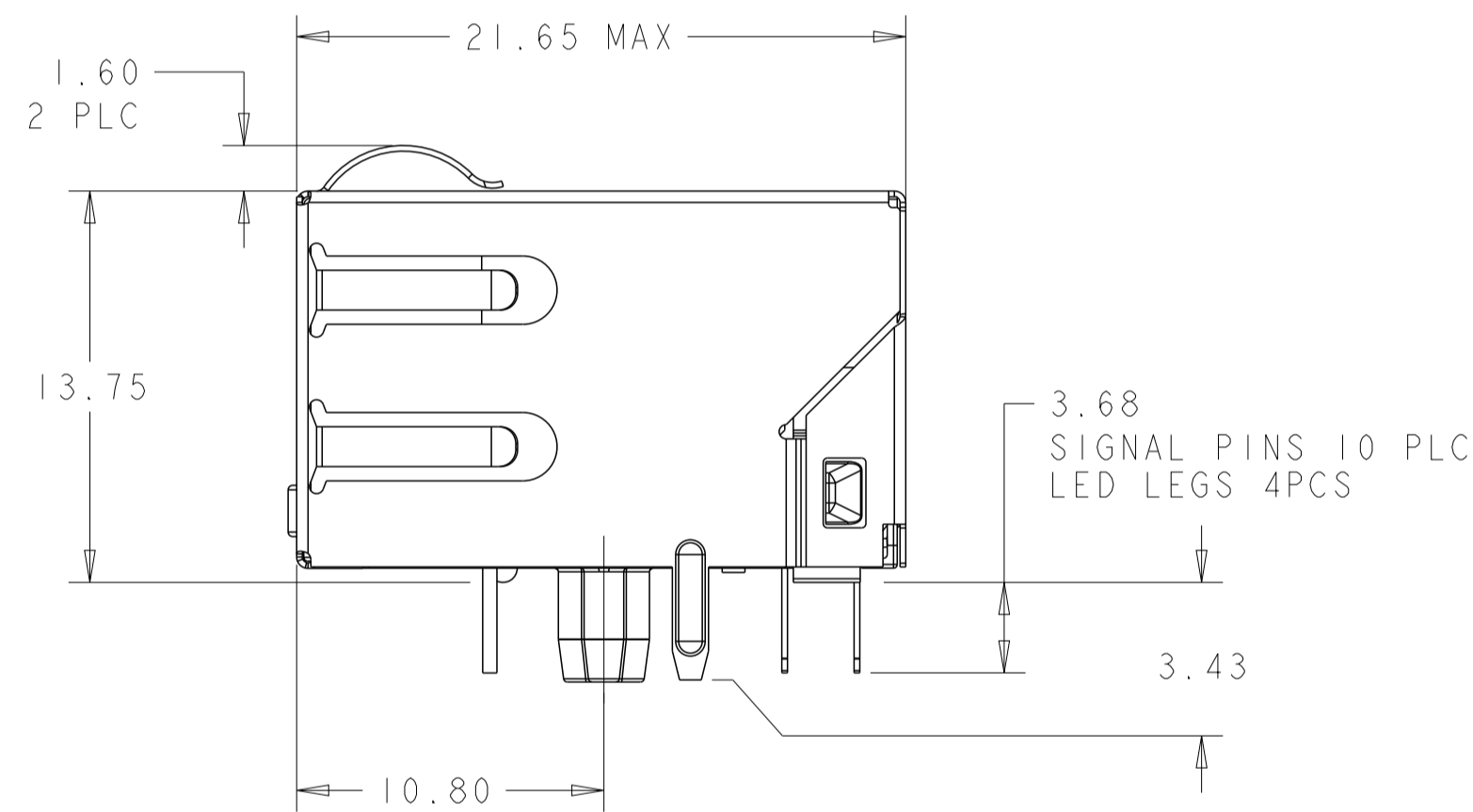
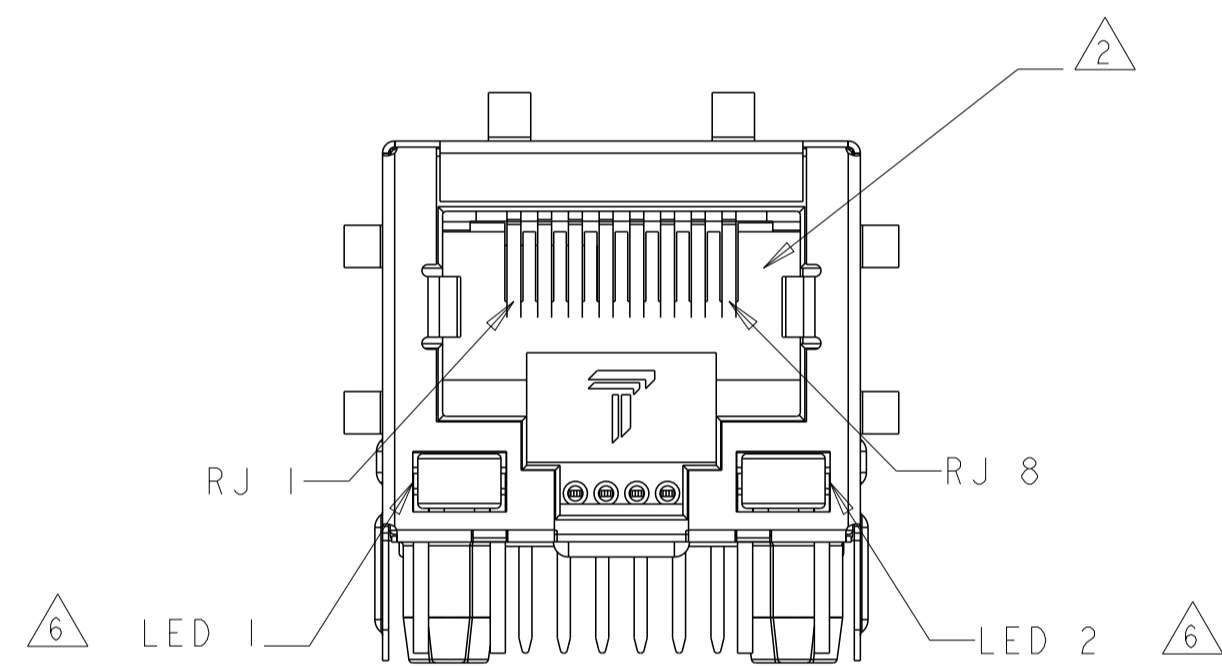

SUGGESTED PANEL CUTOUT  
SCALE 4:1

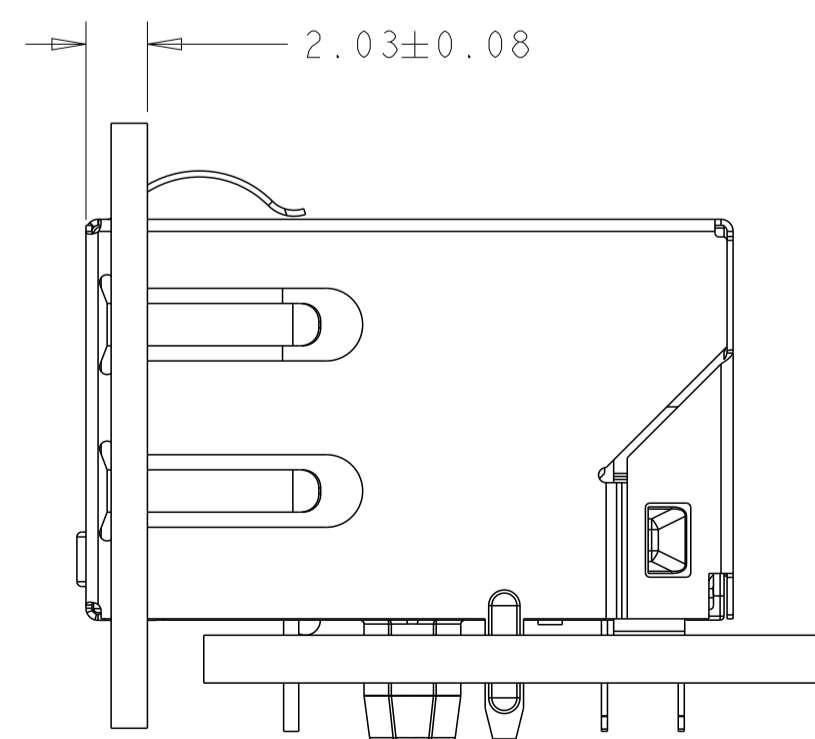

GREEN	-	NO	YELLOW	-	NO	2250027-3
GREEN	YELLOW	NO	GREEN	YELLOW	NO	2250027-2
GREEN	YELLOW	NO	GREEN	-	YES	2250027-1
11-12	12-11	250 OHMS RESISTOR	13-14	14-13	250 OHMS RESISTOR	PART NUMBER
LED 1	LED 2					

THIS DRAWING IS A CONTROLLED DOCUMENT.		OWN ROY LIU 31MAY2013	 DONGGUAN CHINA
DIMENSIONS: mm		CHK TOWER YU/FRANK LIU 31MAY2013	
TOLERANCES UNLESS OTHERWISE SPECIFIED:		APPD TONY YUAN 31MAY2013	MODEL NAME MAGJACK
0 PLC ±0.25 1 PLC ±0.25 2 PLC ±0.25 3 PLC ±0.25 4 PLC ±0.25 ANGLES ±° APPLICATION SPEC ±°		DESC 1X1 4G145 GIGABIT TAB DOWN W/ LED	RESTRICTED TO
PRODUCT SPEC 108-104004		SIZE A1	SCALE 4:1
CUSTOMER DRAWING		DRAWING NO C=2250027	SHEET 1 OF 3
		REV 2	

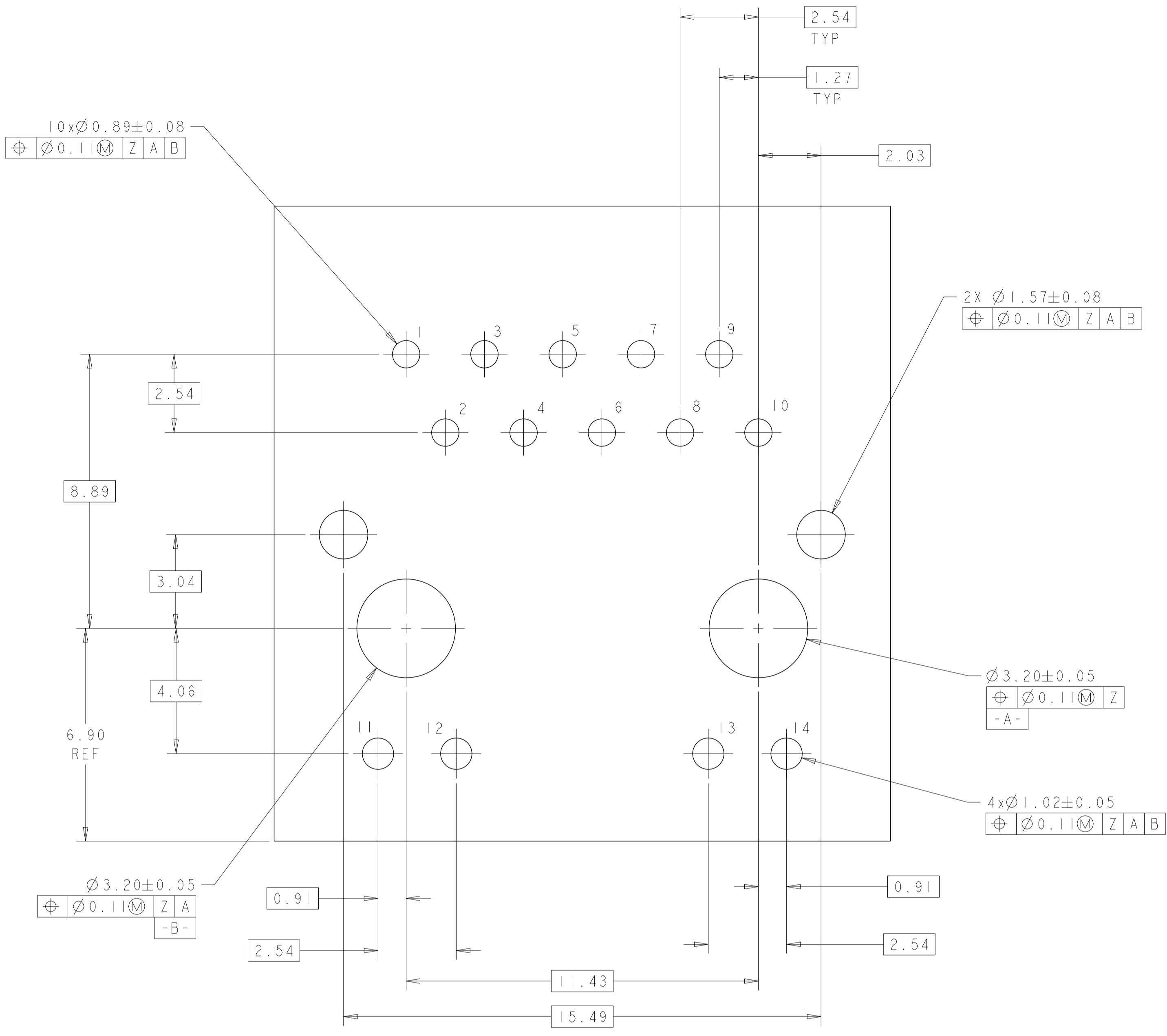

SUGGESTED PCB LAYOUT  
 COMPONENT SIDE

4G145 GIGABIT MAGNETIC CIRCUIT  $\triangle 3 \triangle 5$

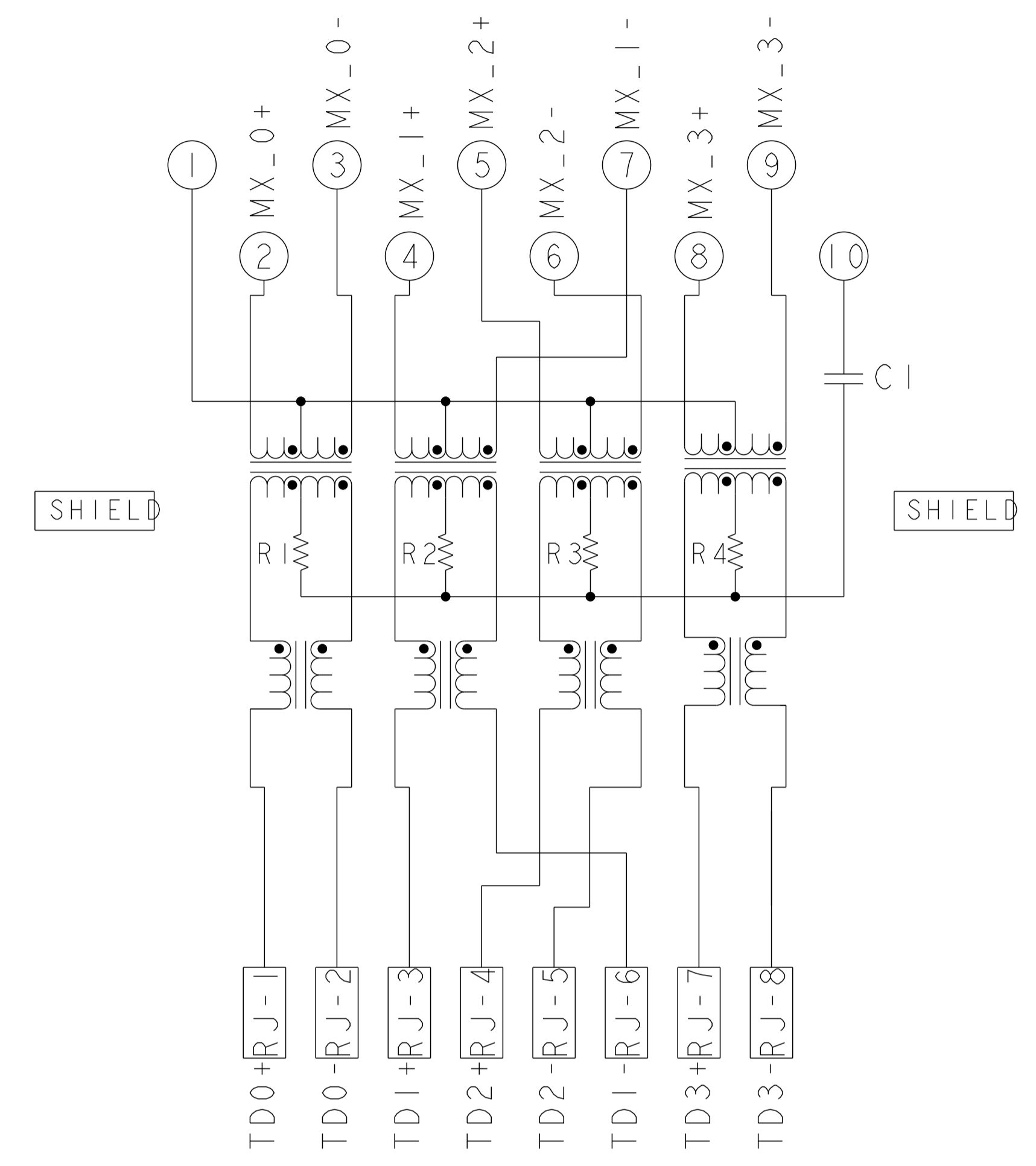

C1=1000pF, 2kV, CAPACITOR  
 R1-R4 = 75 OHMS, RESISTORS

THIS DRAWING IS A CONTROLLED DOCUMENT.		OWN ROY LIU 31MAY2013	<b>trp CONNECTOR</b> a bel group DONGGUAN CHINA
DIMENSIONS: mm		CHK TOWER YU/FRANK LIU 31MAY2013	
TOLERANCES UNLESS OTHERWISE SPECIFIED:		APP'D TONY YUAN 31MAY2013	
0 PLC $\pm 0.25$ 1 PLC $\pm 0.25$ 2 PLC $\pm 0.25$ 3 PLC $\pm 0.25$ 4 PLC $\pm 0.25$ ANGLES $\pm$ APPLICATION SPEC $\pm$		MODEL NAME	
PRODUCT SPEC 108-104004		MAGJACK SINGLE Non-PoE	DESC 1X1 4G145 GIGABIT TAB DOWN W/ LED
		SIZE A1	CAGE CODE DRAWING NO. C=2250027
		CUSTOMER DRAWING	RESTRICTED TO -
		SCALE 4:1	SHEET 2 OF 3 REV 2

C_2250027					STOCK DISPOSITION			
REVISION HISTORY					A: CONTINUE AS IS B: REWORK C: SCRAP			
					D: USE OLD FIRST E: PARTS TO CONFORM F: OTHER			
DATE	REV	CHANGES	REASON	APPROVAL	INVENTORY (A,B,C,D,E,F)	WORK IN PROCESS (A,B,C,F)	SUPPLIER ORDERS (A,E,F)	OPEN CUST ORDERS (A,E,F)
31MAY2013	1	-	INITIAL RELEASE	TONY YUAN	-	-	-	-
14JAN2015	2	EC-1411035 COMPANY LOGO CHANGE	MARKET REQUIREMENT	TONY YUAN	-	-	-	-

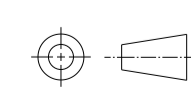
THIS DRAWING IS A CONTROLLED DOCUMENT.		OWN ROY LIU	31MAY2013	 <b>trp</b> CONNECTOR <small>a bel group</small>	DONGGUAN CHINA
DIMENSIONS: mm		CHK TOWER YU/FRANK LIU	31MAY2013		
		APVD TONY YUAN	31MAY2013		
TOLERANCES UNLESS OTHERWISE SPECIFIED:		MODEL NAME		DESC	
0 PLC ±0.25	1 PLC ±0.25	MAGJACK		1X1 4G145 GIGABIT TAB DOWN W/ LED	
2 PLC ±0.25	3 PLC ±	SINGLE Non-PoE		SIZE	CAGE CODE
4 PLC ±	ANGLES	CUSTOMER DRAWING		A1	DRAWING NO
PRODUCT SPEC	APPLICATION SPEC	SCALE		RESTRICTED TO	
108-104004	-	4:1		-	
		SHEET		REV	
		3 OF 3		2	