

# KA78LXXA/KA78L05AA

## 3-Terminal 0.1A Positive Voltage Regulator

### Features

- Maximum Output Current of 100mA
- Output Voltage of 5V, 6V, 8V, 9V, 10V, 12V, 15V, 18V and 24V
- Thermal Overload Protection
- Short Circuit Current Limiting
- Output Voltage Offered in  $\pm 5\%$  Tolerance

### Description

The KA78LXXA/KA78L05AA series of fixed voltage monolithic integrated circuit voltage regulators are suitable for application that required supply current up to 100mA.

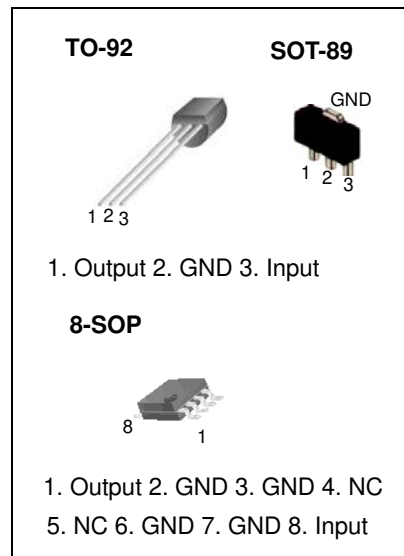

### Internal Block Diagram

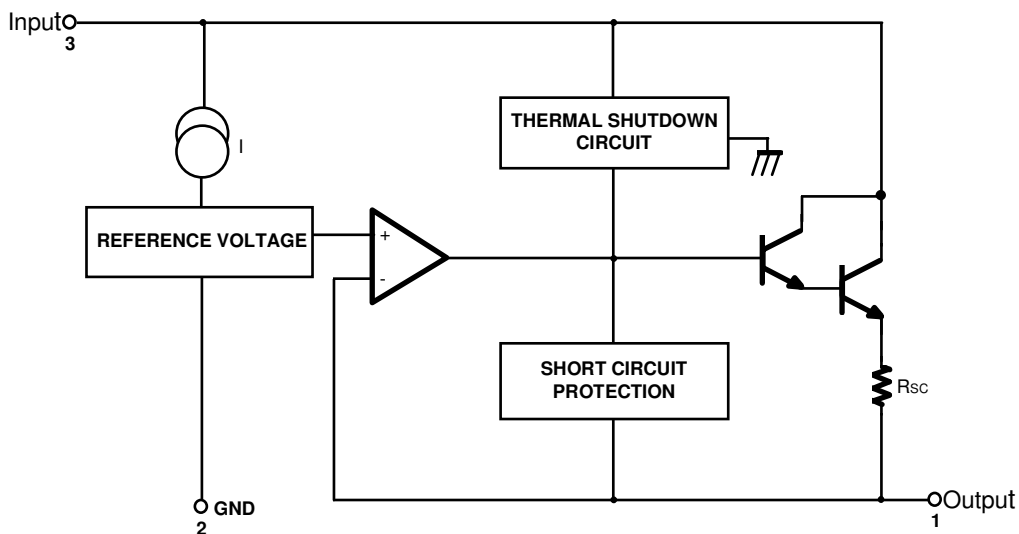

## Absolute Maximum Ratings

Parameter	Symbol	Value	Unit
Input Voltage (for $V_O = 5V$ to $8V$ ) (for $V_O = 12V$ to $18V$ ) (for $V_O = 24V$ )	$V_I$	30 35 40	V V V
Operating Junction Temperature Range	$T_J$	0 ~ +150	°C
Storage Temperature Range	$T_{STG}$	-65 ~ +150	°C
Thermal Resistance Junction-Case TO-92	$R_{\theta JC}$	50	°C/W
Thermal Resistance Junction-Air TO-92 SOT-89 8-SOP	$R_{\theta JA}$	150 225 160	°C/W °C/W °C/W

## Electrical Characteristics(KA78L05A)

( $V_I = 10V$ ,  $I_O = 40mA$ ,  $0^\circ C \leq T_J \leq 125^\circ C$ ,  $C_I = 0.33\mu F$ ,  $C_O = 0.1\mu F$ , unless otherwise specified. (Note1))

Parameter	Symbol	Conditions	Min.	Typ.	Max.	Unit	
Output Voltage	$V_O$	$T_J = 25^\circ C$	4.8	5.0	5.2	V	
Line Regulation (Note1)	$\Delta V_O$	$T_J = 25^\circ C$	$7V \leq V_I \leq 20V$	-	8	150	mV
			$8V \leq V_I \leq 20V$	-	6	100	mV
Load Regulation (Note1)	$\Delta V_O$	$T_J = 25^\circ C$	$1mA \leq I_O \leq 100mA$	-	11	60	mV
			$1mA \leq I_O \leq 40mA$	-	5.0	30	mV
Output Voltage	$V_O$	$7V \leq V_I \leq 20V$	$1mA \leq I_O \leq 40mA$	-	-	5.25	V
		$7V \leq V_I \leq V_{MAX}$ (Note2)	$1mA \leq I_O \leq 70mA$	4.75	-	5.25	V
Quiescent Current	$I_Q$	$T_J = 25^\circ C$	-	2.0	5.5	mA	
Quiescent Current Change	With Line	$\Delta I_Q$	$8V \leq V_I \leq 20V$	-	-	1.5	mA
	With Load	$\Delta I_Q$	$1mA \leq I_O \leq 40mA$	-	-	0.1	mA
Output Noise Voltage	$V_N$	$T_A = 25^\circ C$ , $10Hz \leq f \leq 100kHz$	-	40	-	$\mu V/V_O$	
Temperature Coefficient of $V_O$	$\Delta V_O/\Delta T$	$I_O = 5mA$	-	-0.65	-	mV/°C	
Ripple Rejection	RR	$f = 120Hz$ , $8V \leq V_I \leq 18V$ , $T_J = 25^\circ C$	41	80	-	dB	
Dropout Voltage	$V_D$	$T_J = 25^\circ C$	-	1.7	-	V	

### Note:

- The maximum steady state usable output current and input voltage are very dependent on the heat sinking and/or lead length of the package. The data above represent pulse test conditions with junction temperature as indicated at the initiation of tests.
- Power dissipation  $P_D \leq 0.75W$ .

**Electrical Characteristics(KA78L06A)** (Continued)

( $V_I = 12V$ ,  $I_O = 40mA$ ,  $0^\circ C \leq T_J \leq 125^\circ C$ ,  $C_I = 0.33\mu F$ ,  $C_O = 0.1\mu F$ , unless otherwise specified. (Note 1)

Parameter	Symbol	Conditions	Min.	Typ.	Max.	Unit		
Output Voltage	$V_O$	$T_J = 25^\circ C$	5.75	6.0	6.25	V		
Line Regulation (Note1)	$\Delta V_O$	$T_J = 25^\circ C$	$8.5V \leq V_I \leq 20V$	-	64	175	mV	
			$9V \leq V_I \leq 20V$	-	54	125	mV	
Load Regulation (Note1)	$\Delta V_O$	$T_J = 25^\circ C$	$1mA \leq I_O \leq 100mA$	-	12.8	80	mV	
			$1mA \leq I_O \leq 70mA$	-	5.8	40	mV	
Output Voltage	$V_O$	$8.5 \leq V_I \leq 20V$ , $1mA \leq I_O \leq 40mA$	5.7	-	6.3	V		
		$8.5 \leq V_I \leq V_{MAX}(\text{Note})$ , $1mA \leq I_O \leq 70mA$	5.7	-	6.3	V		
Quiescent Current	$I_Q$	$T_J = 25^\circ C$	-	-	5.5	mA		
		$T_J = 125^\circ C$	-	3.9	6.0	mA		
Quiescent Current Change	With Line	$\Delta I_Q$	$9 \leq V_I \leq 20V$		-	-	1.5	mA
	With Load	$\Delta I_Q$	$1mA \leq I_O \leq 40mA$		-	-	0.1	mA
Output Noise Voltage	$V_N$	$T_A = 25^\circ C$ , $10Hz \leq f \leq 100kHz$	-	40	-	$\mu V/V_O$		
Temperature Coefficient of $V_O$	$\Delta V_O/\Delta T$	$I_O = 5mA$	-	0.75	-	$mV/^\circ C$		
Ripple Rejection	RR	$f = 120Hz$ , $10V \leq V_I \leq 20V$ , $T_J = 25^\circ C$	40	46	-	dB		
Dropout Voltage	$V_D$	$T_J = 25^\circ C$	-	1.7	-	V		

**Note:**

1. The maximum steady state usable output current and input voltage are very dependent on the heat sinking and/or lead length of the package. The data above represent pulse test conditions with junction temperature as indicated at the initiation of tests.
2. Power dissipation  $P_D \leq 0.75W$ .

**Electrical Characteristics(KA78L08A)** (Continued)(V<sub>I</sub> = 14V, I<sub>O</sub> = 40mA, 0°C ≤ T<sub>J</sub> ≤ 125°C, C<sub>I</sub> = 0.33μF, C<sub>O</sub> = 0.1μF, unless otherwise specified. (Note1))

Parameter	Symbol	Conditions	Min.	Typ.	Max.	Unit	
Output Voltage	V <sub>O</sub>	T <sub>J</sub> = 25°C	7.7	8.0	8.3	V	
Line Regulation (Note1)	ΔV <sub>O</sub>	T <sub>J</sub> = 25°C	10.5V ≤ V <sub>I</sub> ≤ 23V	-	10	175	mV
			11V ≤ V <sub>I</sub> ≤ 23V	-	8	125	mV
Load Regulation (Note1)	ΔV <sub>O</sub>	T <sub>J</sub> = 25°C	1mA ≤ I <sub>O</sub> ≤ 100mA	-	15	80	mV
			1mA ≤ I <sub>O</sub> ≤ 40mA	-	8.0	40	mV
Output Voltage	V <sub>O</sub>	10.5V ≤ V <sub>I</sub> ≤ 23V	1mA ≤ I <sub>O</sub> ≤ 40mA	7.6	-	8.4	V
		10.5V ≤ V <sub>I</sub> ≤ V <sub>MAX</sub> (Note2)	1mA ≤ I <sub>O</sub> ≤ 70mA	7.6	-	8.4	V
Quiescent Current	I <sub>Q</sub>	T <sub>J</sub> = 25°C	-	2.0	5.5	mA	
Quiescent Current Change	With Line	ΔI <sub>Q</sub>	11V ≤ V <sub>I</sub> ≤ 23V	-	-	1.5	mA
	With Load	ΔI <sub>Q</sub>	1mA ≤ I <sub>O</sub> ≤ 40mA	-	-	0.1	mA
Output Noise Voltage	V <sub>N</sub>	T <sub>A</sub> = 25°C, 10Hz ≤ f ≤ 100kHz	-	60	-	μV/V <sub>O</sub>	
Temperature Coefficient of V <sub>O</sub>	ΔV <sub>O</sub> /ΔT	I <sub>O</sub> = 5mA	-	-0.8	-	mV/°C	
Ripple Rejection	RR	f = 120Hz, 11V ≤ V <sub>I</sub> ≤ 21V, T <sub>J</sub> = 25°C	39	70	-	dB	
Dropout Voltage	V <sub>D</sub>	T <sub>J</sub> = 25°C	-	1.7	-	V	

**Note:**

1. The maximum steady state usable output current and input voltage are very dependent on the heat sinking and/or lead length of the package. The data above represent pulse test conditions with junction temperature as indicated at the initiation of tests.
2. Power dissipation P<sub>D</sub> ≤ 0.75W.

**Electrical Characteristics(KA78L09A)** (Continued)

( $V_I = 15V$ ,  $I_O = 40mA$ ,  $0^\circ C \leq T_J \leq 125^\circ C$ ,  $C_I = 0.33\mu F$ ,  $C_O = 0.1\mu F$ , unless otherwise specified. (Note1))

Parameter	Symbol	Conditions	Min.	Typ.	Max.	Unit	
Output Voltage	$V_O$	$T_J = 25^\circ C$	8.64	9.0	9.36	V	
Line Regulation (Note1)	$\Delta V_O$	$T_J = 25^\circ C$	$11.5V \leq V_I \leq 24V$	-	90	200	mV
			$13V \leq V_I \leq 24V$	-	100	150	mV
Load Regulation (Note1)	$\Delta V_O$	$T_J = 25^\circ C$	$1mA \leq I_O \leq 100mA$	-	20	90	mV
			$1mA \leq I_O \leq 40mA$	-	10	45	mV
Output Voltage	$V_O$	$11.5V \leq V_I \leq 24V$	$1mA \leq I_O \leq 40mA$	8.55	-	9.45	V
		$11.5V \leq V_I \leq V_{MAX}$ (Note 2)	$1mA \leq I_O \leq 70mA$	8.55	-	9.45	V
Quiescent Current	$I_Q$	$T_J = 25^\circ C$	-	2.1	6.0	mA	
Quiescent Current Change	With Line	$\Delta I_Q$	$13V \leq V_I \leq 24V$	-	-	1.5	mA
	With Load	$\Delta I_Q$	$1mA \leq I_O \leq 40mA$	-	-	0.1	mA
Output Noise Voltage	$V_N$	$T_A = 25^\circ C$ , $10Hz \leq f \leq 100kHz$	-	70	-	$\mu V/V_O$	
Temperature Coefficient of $V_O$	$\Delta V_O/\Delta T$	$I_O = 5mA$	-	-0.9	-	mV/ $^\circ C$	
Ripple Rejection	RR	$f = 120Hz$ , $12V \leq V_I \leq 22V$ , $T_J = 25^\circ C$	38	44	-	dB	
Dropout Voltage	$V_D$	$T_J = 25^\circ C$	-	1.7	-	V	

**Note:**

1. The maximum steady state usable output current and input voltage are very dependent on the heat sinking and/or lead length of the package. The data above represent pulse test conditions with junction temperature as indicated at the initiation of tests.
2. Power dissipation  $P_D \leq 0.75W$ .

**Electrical Characteristics(KA78L10A)** (Continued)

( $V_I = 16V$ ,  $I_O = 40mA$ ,  $0^\circ C \leq T_J \leq 125^\circ C$ ,  $C_I = 0.33 \mu F$ ,  $C_O = 0.1 \mu F$ , unless otherwise specified. (Note1))

Parameter		Symbol	Conditions	Min.	Typ.	Max.	Unit	
Output Voltage		$V_O$	$T_J = 25^\circ C$	9.6	10.0	10.4	V	
Line Regulation (Note1)		$\Delta V_O$	$T_J = 25^\circ C$	$12.5 \leq V_I \leq 25V$	-	100	220	mV
				$14V \leq V_I \leq 25V$	-	100	170	mV
Load Regulation (Note1)		$\Delta V_O$	$T_J = 25^\circ C$	$1mA \leq I_O \leq 100mA$	-	20	94	mV
				$1mA \leq I_O \leq 70mA$	-	10	47	mV
Output Voltage		$V_O$	$12.5V \leq V_I \leq 25V, 1mA \leq I_O \leq 40mA$	9.5	-	10.5	V	
			$12.5V \leq V_I \leq V_{MAX}$ (Note2) $1mA \leq I_O \leq 70mA$	9.5	-	10.5		
Quiescent Current		$I_Q$	$T_J = 25^\circ C$	-	-	6.0	mA	
			$T_J = 125^\circ C$	-	4.2	6.5		
Quiescent Current Change	With Line	$\Delta I_Q$	$12.5 \leq V_I \leq 25V$	-	-	1.5	mA	
	With Load	$\Delta I_Q$	$1mA \leq I_O \leq 40mA$	-	-	0.1	mA	
Output Noise Voltage		$V_N$	$T_A = 25^\circ C, 10Hz \leq f \leq 100kHz$	-	74	-	$\mu V/V_O$	
Temperature Coefficient of $V_O$		$\Delta V_O/\Delta T$	$I_O = 5mA$	-	0.95	-	mV/ $^\circ C$	
Ripple Rejection		RR	$f = 120Hz, 15V \leq V_I \leq 25V, T_J = 25^\circ C$	38	43	-	dB	
Dropout Voltage		$V_D$	$T_J = 25^\circ C$	-	1.7	-	V	

**Notes:**

1. The maximum steady state usable output current and input voltage are very dependent on the heat sinking and/or lead length of the package. The data above represent pulse test conditions with junction temperature as indicated at the initiation of tests.
2. Power dissipation  $P_D \leq 0.75W$ .

**Electrical Characteristics(KA78L12A)** (Continued)

( $V_I = 19V$ ,  $I_O = 40mA$ ,  $0^\circ C \leq T_J \leq 125^\circ C$ ,  $C_I = 0.33 \mu F$ ,  $C_O = 0.1 \mu F$ , unless otherwise specified. (Note 1))

Parameter	Symbol	Conditions	Min.	Typ.	Max.	Unit	
Output Voltage	$V_O$	$T_J = 25^\circ C$	11.5	12	12.5	V	
Line Regulation (Note1)	$\Delta V_O$	$T_J = 25^\circ C$	$14.5V \leq V_I \leq 27V$	-	20	250	mV
			$16V \leq V_I \leq 27V$	-	15	200	mV
Load Regulation (Note1)	$\Delta V_O$	$T_J = 25^\circ C$	$1mA \leq I_O \leq 100mA$	-	20	100	mV
			$1mA \leq I_O \leq 40mA$	-	10	50	mV
Output Voltage	$V_O$	$14.5V \leq V_I \leq 27V$	$1mA \leq I_O \leq 40mA$	11.4	-	12.6	V
		$14.5V \leq V_I \leq V_{MAX}$ (Note 2)	$1mA \leq I_O \leq 70mA$	11.4	-	12.6	V
Quiescent Current	$I_Q$	$T_J = 25^\circ C$	-	2.1	6.0	mA	
Quiescent Current Change	With Line	$\Delta I_Q$	$16V \leq V_I \leq 27V$	-	-	1.5	mA
	With Load	$\Delta I_Q$	$1mA \leq I_O \leq 40mA$	-	-	0.1	mA
Output Noise Voltage	$V_N$	$T_A = 25^\circ C$ , $10Hz \leq f \leq 100kHz$	-	80	-	$\mu V/V_O$	
Temperature Coefficient of $V_O$	$\Delta V_O/\Delta T$	$I_O = 5mA$	-	-1.0	-	mV/ $^\circ C$	
Ripple Rejection	RR	$f = 120Hz$ , $15V \leq V_I \leq 25V$ , $T_J = 25^\circ C$	37	65	-	dB	
Dropout Voltage	$V_D$	$T_J = 25^\circ C$	-	1.7	-	V	

**Note:**

1. The maximum steady state usable output current and input voltage are very dependent on the heat sinking and/or lead length of the package. The data above represent pulse test conditions with junction temperature as indicated at the initiation of tests.
2. Power dissipation  $P_D \leq 0.75W$ .

**Electrical Characteristics(KA78L15A)** (Continued)(V<sub>I</sub> = 23V, I<sub>O</sub> = 40mA, 0°C ≤ T<sub>J</sub> ≤ 125°C, C<sub>I</sub> = 0.33 μF, C<sub>O</sub> = 0.1 μF, unless otherwise specified. (Note1))

Parameter	Symbol	Conditions	Min.	Typ.	Max.	Unit	
Output Voltage	V <sub>O</sub>	T <sub>J</sub> = 25°C	14.4	15	15.6	V	
Line Regulation (Note1)	ΔV <sub>O</sub>	T <sub>J</sub> = 25°C	17.5V ≤ V <sub>I</sub> ≤ 30V	-	25	300	mV
			20V ≤ V <sub>I</sub> ≤ 30V	-	20	250	mV
Load Regulation (Note1)	ΔV <sub>O</sub>	T <sub>J</sub> = 25°C	1mA ≤ I <sub>O</sub> ≤ 100mA	-	25	150	mV
			1mA ≤ I <sub>O</sub> ≤ 40mA	-	12	75	mV
Output Voltage	V <sub>O</sub>	17.5V ≤ V <sub>I</sub> ≤ 30V	1mA ≤ I <sub>O</sub> ≤ 40mA	14.2 5	-	15.7 5	V
		17.5V ≤ V <sub>I</sub> ≤ V <sub>MAX</sub> (Note 2)	1mA ≤ I <sub>O</sub> ≤ 70mA	14.2 5	-	15.7 5	V
Quiescent Current	I <sub>Q</sub>	T <sub>J</sub> = 25°C	-	2.1	6.0	mA	
Quiescent Current Change	With Line	ΔI <sub>Q</sub>	20V ≤ V <sub>I</sub> ≤ 30V	-	-	1.5	mA
	With Load	ΔI <sub>Q</sub>	1mA ≤ I <sub>O</sub> ≤ 40mA	-	-	0.1	mA
Output Noise Voltage	V <sub>N</sub>	T <sub>A</sub> = 25°C, 10Hz ≤ f ≤ 100kHz	-	90	-	μV/V <sub>O</sub>	
Temperature Coefficient of V <sub>O</sub>	ΔV <sub>O</sub> /ΔT	I <sub>O</sub> = 5mA	-	-1.3	-	mV/°C	
Ripple Rejection	RR	f = 120Hz, 18.5V ≤ V <sub>I</sub> ≤ 28.5V, T <sub>J</sub> = 25°C	34	60	-	dB	
Dropout Voltage	V <sub>D</sub>	T <sub>J</sub> = 25°C	-	1.7	-	V	

**Note:**

1. The maximum steady state usable output current and input voltage are very dependent on the heat sinking and/or lead length of the package. The data above represent pulse test conditions with junction temperature as indicated at the initiation of tests.
2. Power dissipation P<sub>D</sub> ≤ 0.75W.



**Electrical Characteristics(KA78L18A)** (Continued)

( $V_I = 27V$ ,  $I_O = 40mA$ ,  $0^\circ C \leq T_J \leq 125^\circ C$ ,  $C_I = 0.33 \mu F$ ,  $C_O = 0.1 \mu F$ , unless otherwise specified. (Note1))

Parameter	Symbol	Conditions	Min.	Typ.	Max.	Unit	
Output Voltage	$V_O$	$T_J = 25^\circ C$	17.3	18	18.7	V	
Line Regulation (Note1)	$\Delta V_O$	$T_J = 25^\circ C$	$21V \leq V_I \leq 33V$	-	145	300	mV
			$22V \leq V_I \leq 33V$	-	135	250	mV
Load Regulation (Note1)	$\Delta V_O$	$T_J = 25^\circ C$	$1mA \leq I_O \leq 100mA$	-	30	170	mV
			$1mA \leq I_O \leq 40mA$	-	15	85	mV
Output Voltage	$V_O$	$21V \leq V_I \leq 33V$	$1mA \leq I_O \leq 40mA$	17.1	-	18.9	V
		$21V \leq V_I \leq V_{MAX}$ (Note 2)	$1mA \leq I_O \leq 70mA$	17.1	-	18.9	V
Quiescent Current	$I_Q$	$T_J = 25^\circ C$	-	2.2	6.0	mA	
Quiescent Current Change	With Line	$\Delta I_Q$	$21V \leq V_I \leq 33V$	-	-	1.5	mA
	With Load	$\Delta I_Q$	$1mA \leq I_O \leq 40mA$	-	-	0.1	mA
Output Noise Voltage	$V_N$	$T_A = 25^\circ C$ , $10Hz \leq f \leq 100kHz$	-	150	-	$\mu V/V_O$	
Temperature Coefficient of $V_O$	$\Delta V_O/\Delta T$	$I_O = 5mA$	-	-1.8	-	mV/ $^\circ C$	
Ripple Rejection	RR	$f = 120Hz$ , $23V \leq V_I \leq 33V$ , $T_J = 25^\circ C$	34	48	-	dB	
Dropout Voltage	$V_D$	$T_J = 25^\circ C$	-	1.7	-	V	

**Note:**

1. The maximum steady state usable output current and input voltage are very dependent on the heat sinking and/or lead length of the package. The data above represent pulse test conditions with junction temperature as indicated at the initiation of tests.
2. Power dissipation  $P_D \leq 0.75W$ .

**Electrical Characteristics(KA78L24A)** (Continued)(V<sub>I</sub> = 33V, I<sub>O</sub> = 40mA, 0°C ≤ T<sub>J</sub> ≤ 125°C, C<sub>I</sub> = 0.33 μF, C<sub>O</sub> = 0.1 μF, unless otherwise specified. (Note1))

Parameter	Symbol	Conditions	Min.	Typ.	Max.	Unit	
Output Voltage	V <sub>O</sub>	T <sub>J</sub> = 25°C	23	24	25	V	
Line Regulation (Note1)	ΔV <sub>O</sub>	T <sub>J</sub> = 25°C	27V ≤ V <sub>I</sub> ≤ 38V	-	160	300	mV
			28V ≤ V <sub>I</sub> ≤ 38V	-	150	250	mV
Load Regulation (Note1)	ΔV <sub>O</sub>	T <sub>J</sub> = 25°C	1mA ≤ I <sub>O</sub> ≤ 100mA	-	40	200	mV
			1mA ≤ I <sub>O</sub> ≤ 40mA	-	20	100	mV
Output Voltage	V <sub>O</sub>	27V ≤ V <sub>I</sub> ≤ 38V	1mA ≤ I <sub>O</sub> ≤ 40mA	22.8	-	25.2	V
		27V ≤ V <sub>I</sub> ≤ V <sub>MAX</sub> (Note2)	1mA ≤ I <sub>O</sub> ≤ 70mA	22.8	-	25.2	V
Quiescent Current	I <sub>Q</sub>	T <sub>J</sub> = 25°C	-	2.2	6.0	mA	
Quiescent Current Change	With Line	ΔI <sub>Q</sub>	28V ≤ V <sub>I</sub> ≤ 38V	-	-	1.5	mA
	With Load	ΔI <sub>Q</sub>	1mA ≤ I <sub>O</sub> ≤ 40mA	-	-	0.1	mA
Output Noise Voltage	V <sub>N</sub>	T <sub>A</sub> = 25°C, 10Hz ≤ f ≤ 100kHz	-	200	-	μV/V <sub>O</sub>	
Temperature Coefficient of V <sub>O</sub>	ΔV <sub>O</sub> /ΔT	I <sub>O</sub> = 5mA	-	-2.0	-	mV/°C	
Ripple Rejection	RR	f = 120Hz, 28V ≤ V <sub>I</sub> ≤ 38V, T <sub>J</sub> = 25°C	34	45	-	dB	
Dropout Voltage	V <sub>D</sub>	T <sub>J</sub> = 25°C	-	1.7	-	V	

**Note:**

1. The maximum steady state usable output current and input voltage are very dependent on the heat sinking and/or lead length of the package. The data above represent pulse test conditions with junction temperature as indicated at the initiation of tests.
2. Power dissipation P<sub>D</sub> ≤ 0.75W.

## Absolute Maximum Ratings

Parameter	Symbol	Value	Unit
Input Voltage (for $V_O = 5V$ to $8V$ ) (for $V_O = 12V$ to $18V$ ) (for $V_O = 24V$ )	$V_I$	30 35 40	V V V
Operating Junction Temperature Range	$T_J$	0 ~ +150	°C
Storage Temperature Range	$T_{STG}$	-65 ~ +150	°C

## Electrical Characteristics(KA78L05AA) (Continued)

( $V_I = 10V$ ,  $I_O = 40mA$ ,  $0^\circ C \leq T_J \leq 125^\circ C$ ,  $C_I = 0.33 \mu F$ ,  $C_O = 0.1 \mu F$ , unless otherwise specified. (Note1))

Parameter	Symbol	Conditions	Min.	Typ.	Max.	Unit	
Output Voltage	$V_O$	$T_J = 25^\circ C$	4.9	5.0	5.1	V	
Line Regulation (Note1)	$\Delta V_O$	$T_J = 25^\circ C$	$7V \leq V_I \leq 20V$	-	8	150	mV
			$8V \leq V_I \leq 20V$	-	6	100	mV
Load Regulation (Note1)	$\Delta V_O$	$T_J = 25^\circ C$	$1mA \leq I_O \leq 100mA$	-	11	50	mV
			$1mA \leq I_O \leq 40mA$	-	5.0	25	mV
Output Voltage	$V_O$	$7V \leq V_I \leq 20V$	$1mA \leq I_O \leq 40mA$	-	-	5.15	V
		$7V \leq V_I \leq V_{MAX}$ (Note2)	$1mA \leq I_O \leq 70mA$	4.85	-	5.15	V
Quiescent Current	$I_Q$	$T_J = 25^\circ C$	-	2.0	5.5	mA	
Quiescent Current Change	With Line	$\Delta I_Q$	$8V \leq V_I \leq 20V$	-	-	1.5	mA
	With Load	$\Delta I_Q$	$1mA \leq I_O \leq 40mA$	-	-	0.1	mA
Output Noise Voltage	$V_N$	$T_A = 25^\circ C$ , $10Hz \leq f \leq 100kHz$	-	40	-	$\mu V/V_O$	
Temperature Coefficient of $V_O$	$\Delta V_O/\Delta T$	$I_O = 5mA$	-	-0.65	-	mV/°C	
Ripple Rejection	RR	$f = 120Hz$ , $8V \leq V_I \leq 18V$ , $T_J = 25^\circ C$	41	80	-	dB	
Dropout Voltage	$V_D$	$T_J = 25^\circ C$	-	1.7	-	V	

### Note:

- The maximum steady state usable output current and input voltage are very dependent on the heat sinking and/or lead length of the package. The data above represent pulse test conditions with junction temperature as indicated at the initiation of tests.
- Power dissipation  $P_D \leq 0.75W$ .

## Typical Application

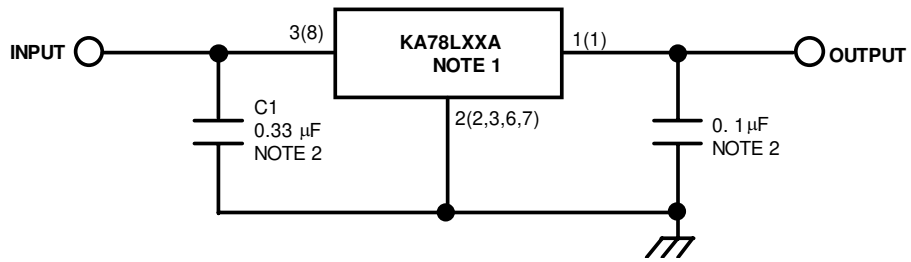

'( )' : 8SOP Type

**Note:**

1. To specify an output voltage, substitute voltage value for "XX".
2. Bypass Capacitors are recommend for optimum stability and transient response and should be located as close as possible to the regulator

## Mechanical Dimensions

Package

Dimensions in millimeters

### TO-92 Straight Lead for Bulk Packing

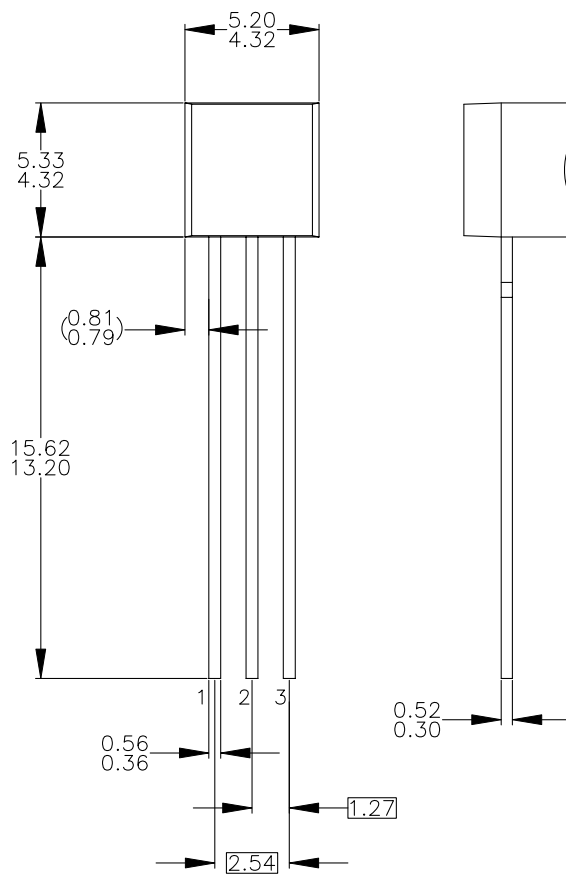

NOTES: UNLESS OTHERWISE SPECIFIED

- A) DRAWING WITH REFERENCE TO JEDEC TO-92 RECOMMENDATIONS.
- B) ALL DIMENSIONS ARE IN MILLIMETERS.
- C) DRAWING CONFORMS TO ASME Y14.5M-1994.

**Mechanical Dimensions** (Continued)

Package

Dimensions in millimeters

**TO-92 Formed Lead For T&R and Ammo Packing**

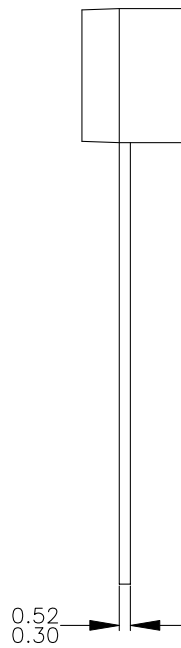
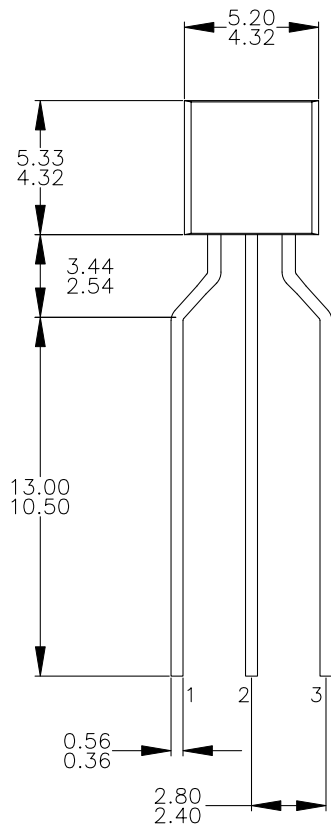

NOTES: UNLESS OTHERWISE SPECIFIED

- A) DRAWING WITH REFERENCE TO JEDEC TO-92 RECOMMENDATIONS.
- B) ALL DIMENSIONS ARE IN MILLIMETERS.
- C) DRAWING CONFORMS TO ASME Y14.5M-1994.

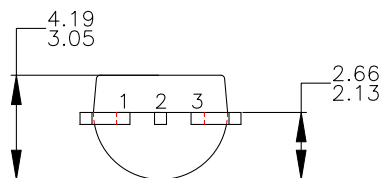

## Mechanical Dimensions (Continued)

### Package

Dimensions in millimeters

## 8-SOP

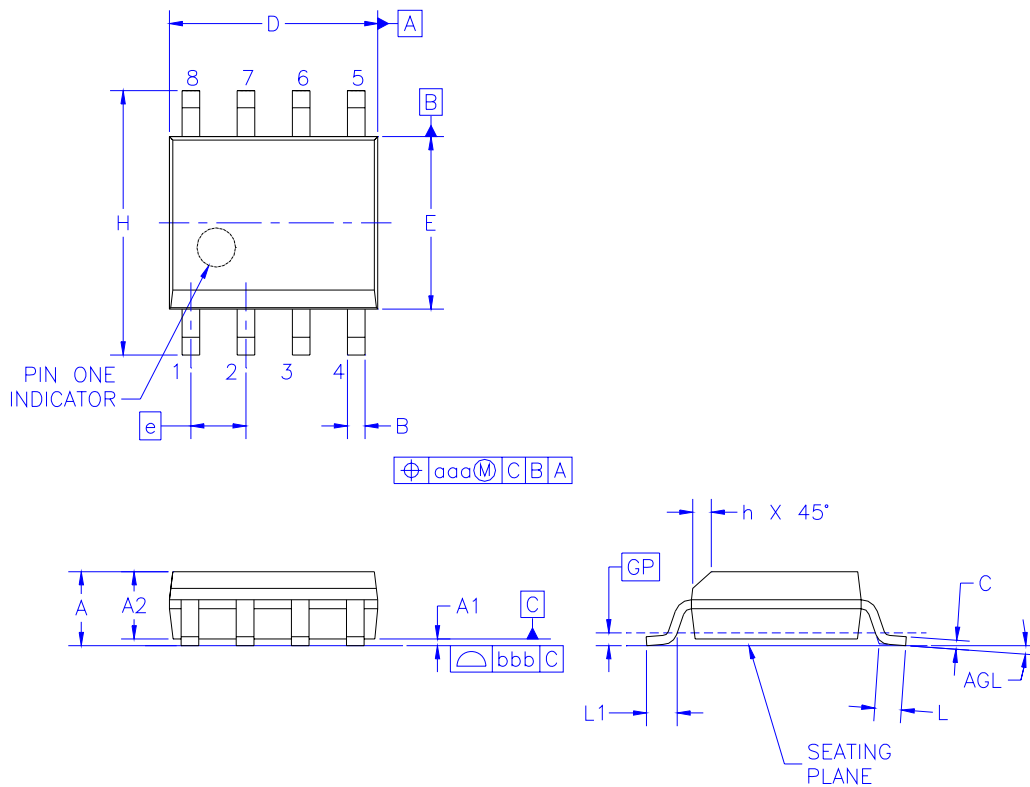

Symbol	Min	Nom	Max
A	-	-	1.75
A1	0.10	0.15	0.25
A2	1.25	1.45	1.50
B	0.35	0.37	0.51
C	0.19	0.20	0.25
D	4.80	4.90	5.00
E	3.80	3.90	4.00
e	1.27BSC		
H	5.79	5.99	6.20
h	0.25	-	0.50
L	0.50	0.70	0.90
GP	0.36 BSC		
q	0	-	8
aaa	-	-	0.25
bbb	-	-	0.10

# Mechanical Dimensions (Continued)

Package

Dimensions in millimeters

## SOT-89

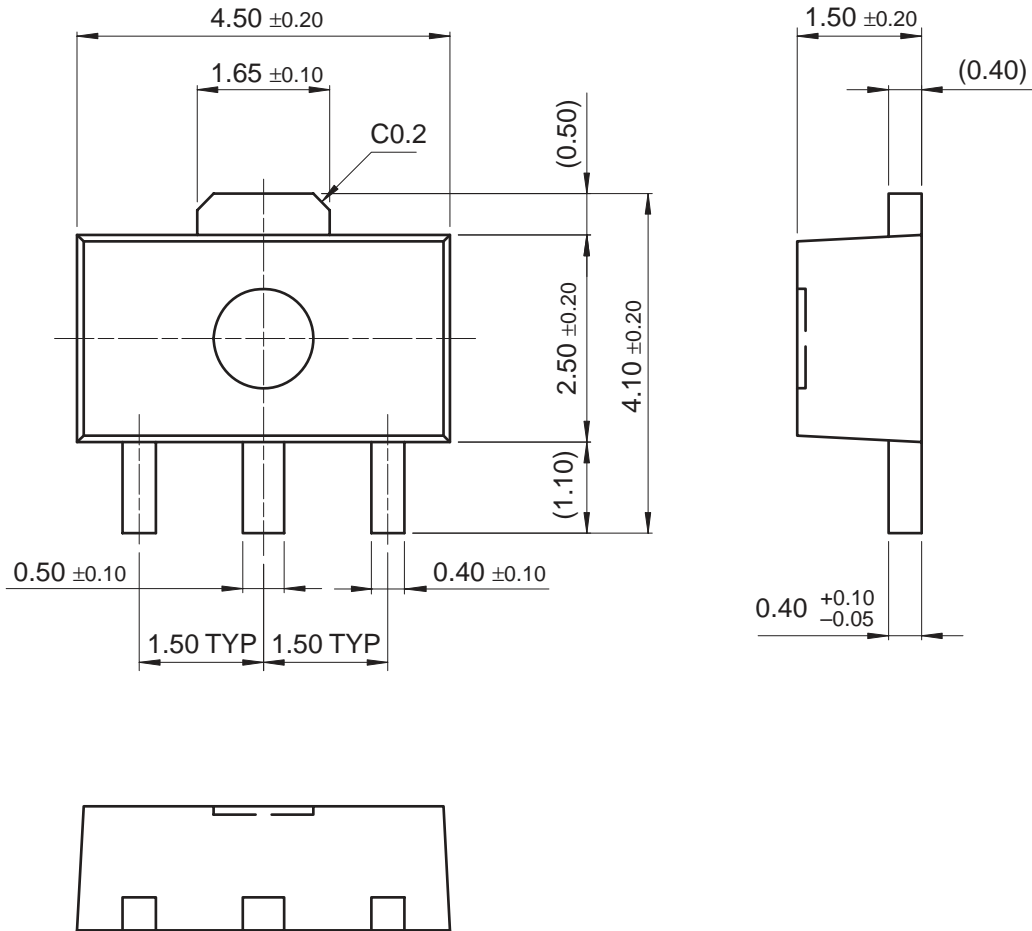



## Ordering Information

Product Number	Package	Shipping	Output Voltage Tolerance	Operating Temperature				
KA78L05AZTA	TO-92	Ammo	5%	0 ~ +125 °C				
KA78L05AZTF		Tape & Reel						
KA78L05AZBU		Bulk						
KA78L06AZTA		Ammo						
KA78L06AZBU		Bulk						
KA78L08AZTA		Ammo						
KA78L08AZTF		Tape & Reel						
KA78L08AZBU		Bulk						
KA78L09AZTA		Ammo						
KA78L09AZBU		Bulk						
KA78L10AZTA		Ammo						
KA78L10AZBU		Bulk						
KA78L12AZTA		Ammo						
KA78L12AZTF		Tape & Reel						
KA78L12AZBU		Bulk						
KA78L15AZTA		Ammo						
KA78L15AZBU		Bulk						
KA78L18AZTA		Ammo						
KA78L18AZBU		Bulk						
KA78L24AZTA		Ammo						
KA78L24AZBU	Bulk							
KA78L05AMTF	SOT-89	Tape & Reel	5%	0 ~ +125 °C				
KA78L05AMTM		Tape & Reel						
KA78L08AMTF		Tape & Reel						
KA78L09AMTF		Tape & Reel						
KA78L12AMTF		Tape & Reel						
KA78L05AD	8-SOP	Tube			5%	0 ~ +125 °C		
KA78L05ADTF		Tape & Reel						
KA78L08AD		Tube						
KA78L08ADTF		Tape & Reel						
KA78L12AD		Tube						
KA78L12ADTF		Tape & Reel						
KA78L05AAZTA	TO-92	Ammo					2%	0 ~ +125 °C
KA78L05AAZBU		Bulk						

- For information on tape & reel and ammo pack specifications, including part orientation and tape sizes, please refer to our tape and reel data, [www.fairchildsemi.com/products/discrete/pdf/to92\\_tr.pdf](http://www.fairchildsemi.com/products/discrete/pdf/to92_tr.pdf).

#### **DISCLAIMER**

FAIRCHILD SEMICONDUCTOR RESERVES THE RIGHT TO MAKE CHANGES WITHOUT FURTHER NOTICE TO ANY PRODUCTS HEREIN TO IMPROVE RELIABILITY, FUNCTION OR DESIGN. FAIRCHILD DOES NOT ASSUME ANY LIABILITY ARISING OUT OF THE APPLICATION OR USE OF ANY PRODUCT OR CIRCUIT DESCRIBED HEREIN; NEITHER DOES IT CONVEY ANY LICENSE UNDER ITS PATENT RIGHTS, NOR THE RIGHTS OF OTHERS.

#### **LIFE SUPPORT POLICY**

FAIRCHILD'S PRODUCTS ARE NOT AUTHORIZED FOR USE AS CRITICAL COMPONENTS IN LIFE SUPPORT DEVICES OR SYSTEMS WITHOUT THE EXPRESS WRITTEN APPROVAL OF THE PRESIDENT OF FAIRCHILD SEMICONDUCTOR CORPORATION. As used herein:

1. Life support devices or systems are devices or systems which, (a) are intended for surgical implant into the body, or (b) support or sustain life, and (c) whose failure to perform when properly used in accordance with instructions for use provided in the labeling, can be reasonably expected to result in a significant injury of the user.
2. A critical component in any component of a life support device or system whose failure to perform can be reasonably expected to cause the failure of the life support device or system, or to affect its safety or effectiveness.