

LOC		DIST		REVISIONS			
IF	LR	DATE	DRN	APVD			
A		RELEASED PER ECO-08-023091	16SEP08	JDP	SLB		

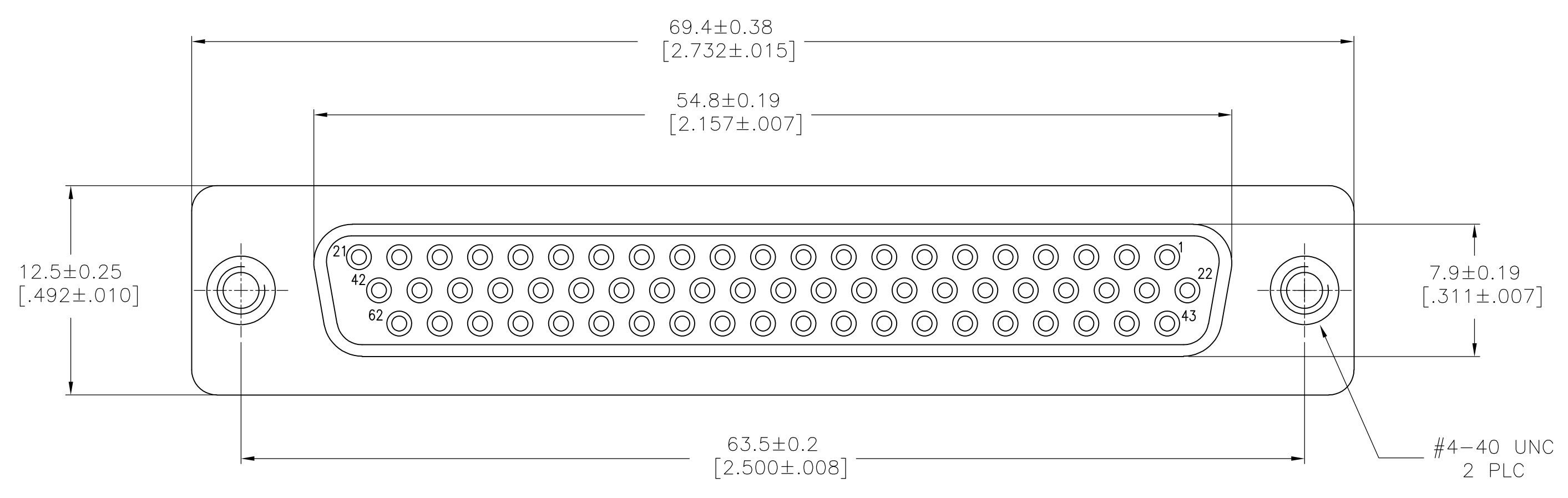

- HOUSING MATERIAL: PBT, GLASS FILLED, BLACK, UL 94V-0 RATED.
 - CONTACT MATERIAL: PHOSPHOR BRONZE.
 - CONTACT FINISH: GOLD PLATE IN MATING AREA (SEE TABLE), 0.00305 [120μ] MIN TIN PLATE ON SOLDER TAIL, BOTH OVER 0.00127 [50μ] MIN NICKEL UNDERPLATE.
 - SHELL: STEEL, NICKEL PLATE.
 - THREADED INSERT/BOARDLOCK: BRASS, 0.00254 [100μ] MIN TIN PLATE.
- △ DATUMS -X- AND -Y- TO BE ESTABLISHED BY CUSTOMER.

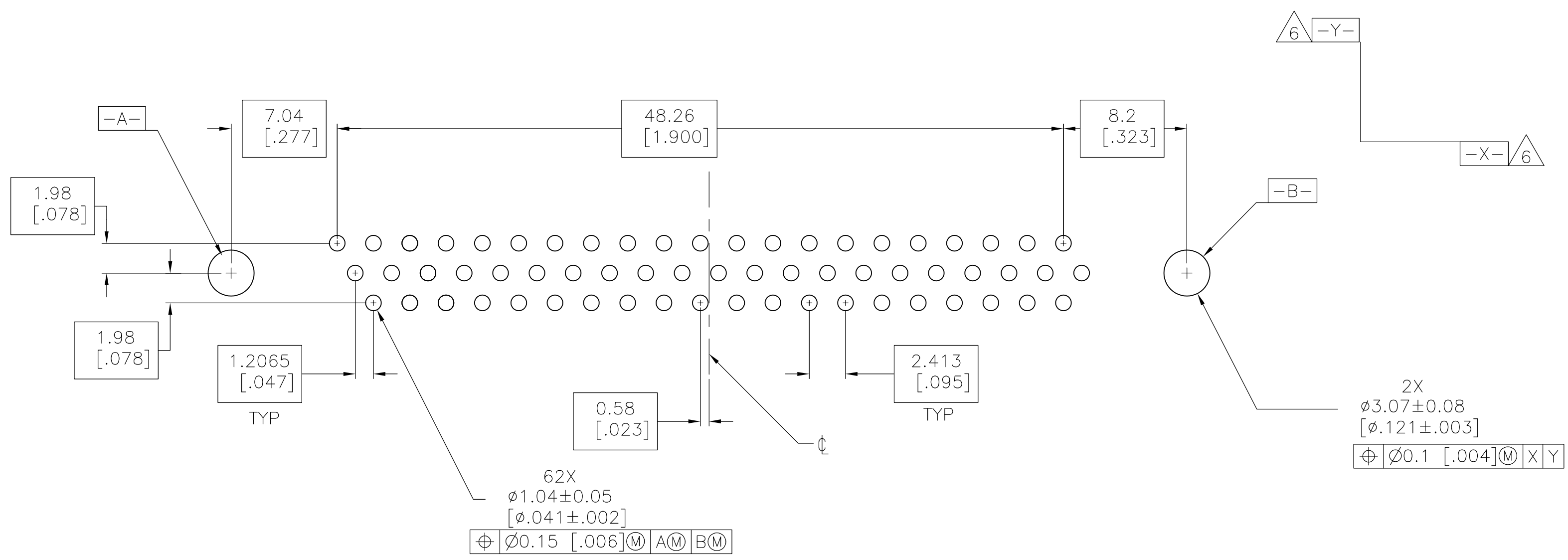
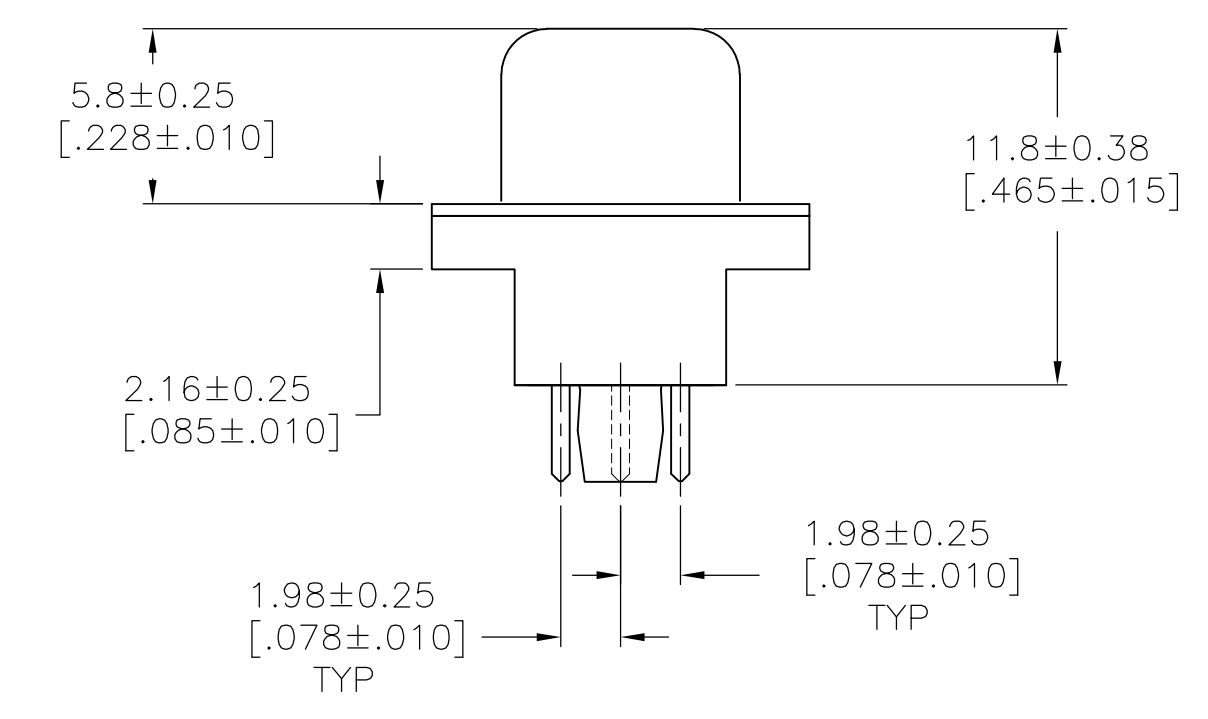
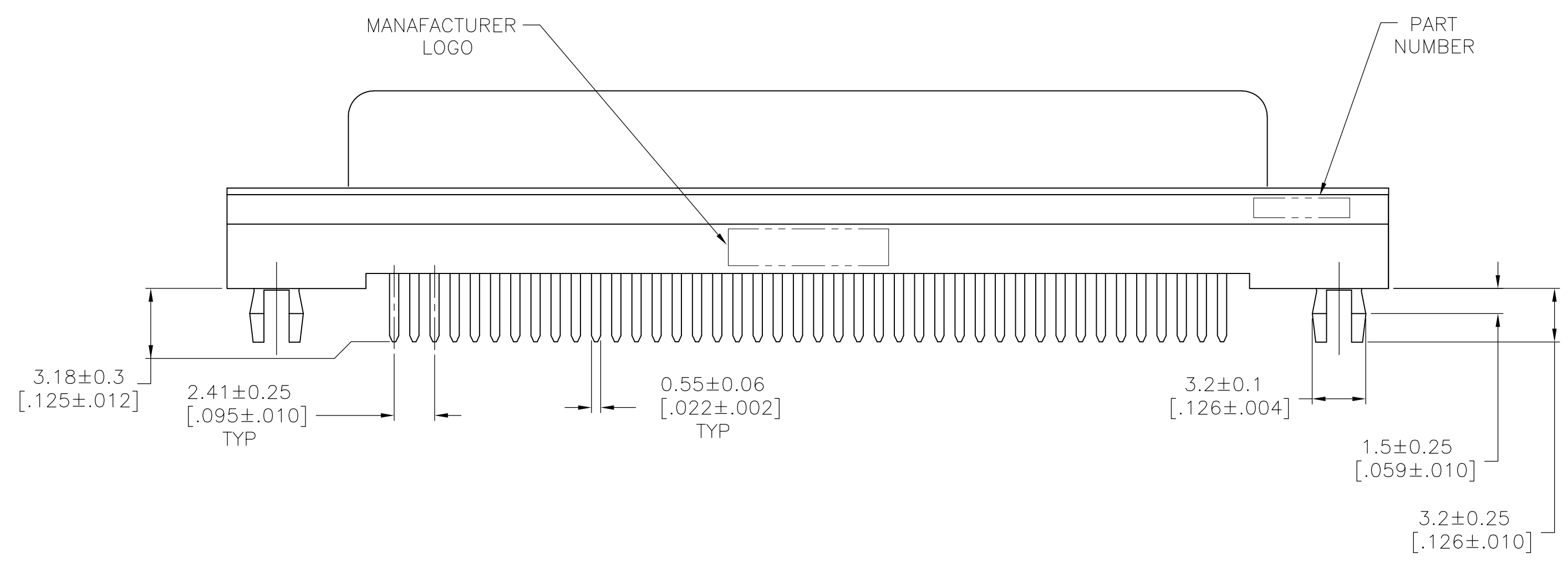

RECOMMENDED PCB LAYOUT

0.00076 [30μ] MIN	2057140-1
CONTACT MATING AREA FINISH	PART NUMBER

THIS DRAWING IS A CONTROLLED DOCUMENT.		DWN: J. POLIGNONE 11JUL08	Tyco Electronics Corporation Harrisburg, PA 17105-3608	
DIMENSIONS: mm [INCHES]	TOLERANCES UNLESS OTHERWISE SPECIFIED:	CHK: S. BOLASH 11JUL08	NAME: S. BOLASH 11JUL08	RESTRICTED TO: -
0 PLC ± -	1 PLC ± -	PRODUCT SPEC: 108-1092	SIZE: A1	CAGE CODE: 00779
2 PLC ± -	3 PLC ± -	APPLICATION SPEC: 114-13199	DRAWING NO: 2057140	SCALE: 4:1
4 PLC ± -	ANGLES ± -	WEIGHT: -	SHEET: 1 OF 1	REV: A
MATERIAL: -	FINISH: -	CUSTOMER DRAWING		