IMPACT 100 Ohm Interconnect Systems

1. SCOPE

1.1. Content

This specification defines the performance, tests and quality requirements for the TE Connectivity (TE) IMPACT 100 Ohm Interconnect Systems which consists of modular groupings of broad-edge coupled signals with optional integrated guidance. These connectors are two-piece devices, which connect two printed circuit boards (PCBs). The right angle receptacle connectors (daughtercard) and header pin connectors (backplane) are through-hole devices with Eye-of-the-Needle (EON) compliant pin terminals.

1.2. Qualification

When tests are performed on the subject product line, procedures specified in Figure 1 shall be used. All inspections shall be performed using the applicable inspection plan and product drawing.

Successful qualification testing on the subject product line was completed on 25 Feb 11. The Qualification Test Report number for this testing is 501-743. This documentation is on file at and available from Engineering Practices and Standards (EPS).

2. APPLICABLE DOCUMENTS

The following documents form a part of this specification to the extent specified herein. Unless otherwise specified, the latest edition of the document applies. In the event of conflict between the requirements of this specification and the product drawing, the product drawing shall take precedence. In the event of conflict between the requirements of this specification and the referenced documents, this specification shall take precedence.

2.1. TE Connectivity Document

501-743: IMPACT Interconnect Systems (Qualification Test Report)

2.2. Industry Document

EIA-364: Electrical Connector/Socket Test Procedures Including Environmental Classifications

2.3. Reference Document

109-197: TE Test Specifications vs. EIA and IEC Test Methods (Test Specification)

2.4. The header pins are lubricated in the contact area with an approved lubricant according to industry standard Telcordia GR-1217-CORE, Section 5.3.

3. REQUIREMENTS

3.1. Design and Construction

Product shall be of the design, construction and physical dimensions specified on the applicable product drawing.

IMPACT and Molex are trademarks of Molex, Incorporated

3.2. Materials

Materials used in the construction of this product shall be as specified on the applicable product drawing.

3.3. Ratings

- Agency Voltage: 29.9 volts AC, rms DC maximum
- Non-Agency Voltage: 150 volts AC, rms DC maximum
- Current: 0.75 ampere maximum per contact
- Temperature: -55 to 85°C

3.4. Performance and Test Description

Product is designed to meet the electrical, mechanical and environmental performance requirements specified in Figure 1. Unless otherwise specified, all tests shall be performed at ambient environmental conditions.

3.5. Test Requirements and Procedures Summary

Test Description	Requirement	Procedure
Initial examination of product	Meets requirements of product drawing.	EIA-364-18. Visual and dimensional (C of C) inspection per product drawing.
Final examination of product	Meets visual requirements.	EIA-364-18. Visual inspection.

ELECTRICAL

Low Level Contact Resistance (LLCR)	ΔR 10 milliohms maximum. Refer to Figure 5 for typical initial bulk resistances.	EIA-364-23. Subject specimens to 100 milliamperes maximum and 20 millivolts maximum open circuit voltage. See Figure 3.
Insulation resistance.	1000 megohms minimum.	EIA-364-21. 500 volts DC, 2 minutes hold. Test between adjacent contacts of unmated specimens.
Withstanding voltage.	One minute hold with no breakdown, flashover or leakage exceeding 5 milliamperes	EIA-364-20, Condition 1. 500 volts AC at sea level. Test between adjacent contacts of unmated specimens.
Compliant pin interface resistance.	One million maximum	EIA-364-23. Subject specimens to 100 milliamperes maximum and 20 millivolts maximum open circuit voltage. Contact inserted into PCB.

MECHANICAL

Sinusoidal vibration.	No discontinuities of 10 nanoseconds or longer duration. See Note.	EIA-364-28. Subject mated specimens to 10 to 500 to 10 Hz traversed in 1 minute with 1.5mm maximum total excursion or 10 G peak. Three hours in each of 3 mutually perpendicular planes. See Figure 4.
-----------------------	--	---

Figure 1 (cont)

Test Description	Requirement	Procedure
Mechanical shock.	No discontinuities of 10 nanoseconds or longer duration. See Note.	EIA-364-27, Condition H. Subject mated specimens to 30 G's half-sine shock pulses of 11 seconds duration. Three shocks in each direction applied along 3 mutually perpendicular planes, 18 total shocks. See Figure 4.
Durability	See Note.	EIA-364-9. Mate and unmate specimens for the numbers of cycles specified in Figure 2 at a maximum rate of 500 cycles per hour.
Mating force.	35 grams maximum (average per pin, over entire assembly)	EIA-364-13. Measure force necessary to mate daughtercard and backplane at a maximum rate of 25.4mm per minute.
Unmating force.	15 grams minimum initial, 8 grams minimum final (average per pin, over entire assembly)	EIA-364-13. Measure force necessary to unmate daughtercard and backplane at a maximum rate of 25.4mm per minute.
Compliant pin insertion force.	26.7 N maximum for headers. 17.8 N maximum for receptacles These max values are intended for press sizing only. The peak force value will occur prior to the final seating of the connector. Plating surface finish and PCB materials will impact actual values.	EIA-364-5. Measure force required to insert a contact into the PCB at a maximum rate 5.08mm per minute.
Compliant pin retention force.	3.6 N minimum for both headers and receptacles. Data reflects minimum average values for retention forces when tested in plated through holes drilled and plated as described in the appropriate impact application specification. Plating surface finish and PCB materials will impact actual values. Radial hole deformation: 1.5 mils maximum Axial hole deformation: 1.0 mil maximum	EIA-364-5. Measure force required to remove a contact from the PCB at a maximum rate 5.08mm per minute.
Minute/thermal disturbance.	See Note.	EIA-364-110. (Thermal Cycling), condition A, Duration A. Subject mated specimens to 10 cycles between 15 and 85°C. Dwell until acclimated, transition approximately 10 degrees per minute.

Figure 1 (cont)

Test Description	Requirement	Procedure
ENVIRONMENTAL		
Thermal shock	See Note.	EIA-364-32, Test Condition I. Subject mated specimens to 5 cycles between -55 and 85°C with 30 minute dwells at temperature extremes and 1 minute transition between temperatures.
Humidity/temperature cycling.	See Note.	EIA-364-31, Method III. Subject mated specimens to 500 hours between 25 and 65°C at 80 to 100% RH.
Temperature life.	See Note.	EIA-364-17, Method A, Test Condition 3, Test Time Condition C. Subject mated specimens to 85°C for 500 hours.
Mixed flowing gas.	See Note.	EIA-364-65, Class IIA (4gas). Subject specimens to environmental Class IIA for 20 days (10 days unmated, followed by 10 days mated). Measure LLCR every 5 days.
Dust.	See Note.	EIA-364-91. Subject unmated specimens to #1 (benign) dust for 1 hour. Specimens shall not be removed from the chamber for a minimum of 1 hour after completion of the test.



NOTE

Shall meet visual requirements, show no physical damage, and meet requirements of additional tests as specified in the Product Qualification and Requalification Test Sequence shown in Figure 2.

Figure 1 (end)

3.6. Product Qualification and Requalification Test Sequence

Test or Examination	Test Group (a)						
	1	2	3	4	5	6	7
	Test Sequence (e)						
Initial Examination of Product	2	1	1	1	1	1	1
LLCR	4,6	3,5	2,5,7,9	2,4,7,9,11	2,4,6,8,10,12,14,16,18		
Insulation Resistance						2,6	
Withstanding voltage						3,7	
Compliant pin interface resistance							3,6
Sinusoidal vibration				6			
Mechanical shock				8			
Durability			3(f),8(f)	3(f),10(f)	5(g),17(g)		
Mating force	3,8	2,7					
Unmating force	7	6					
Compliant pin insertion force	1						2,5(d)
Compliant pin retention force							4,7
Minute/thermal disturbance					15		
Thermal shock		4				4	
Humidity/temperature cycling			6			5	
Temperature life	5				3(i)		
Mixed flowing gas					7,9,11,13		
Dust			4	5			
Final examination of product	9	8	10	12	19	8	8(h)



NOTE

- a. See Paragraph 4.1.A.
- b. Separate specimens must be run for LLCR and discontinuity monitoring.
- c. This test group not mounted on PCB's.
- d. Remove and replace specimens on PCB 1 time.
- e. Numbers indicate sequence in which tests are performed.
- f. 100 cycles only.
- g. 98 cycles only.
- h. Cross section compliant pin joints (initial and reworked connectors).
- i. 300 HOURS.

Figure 2

4. QUALITY ASSURANCE PROVISIONS

4.1. Qualification Testing

A. Specimen Selection

Specimens shall be prepared in accordance with applicable instruction sheets and shall be selected at random from current production. Test groups 1, 2, 3, 4, 6 and 7 shall each consist of 5 mated pairs. Test group 5 shall consist of 10 mated pairs.

B. Test Sequence

Qualification inspection shall be verified by testing specimens as specified in Figure 2.

4.2. Requalification Testing

If changes significantly affecting form, fit or function are made to the product or manufacturing process, product assurance shall coordinate requalification testing, consisting of all or part of the original testing sequence as determined by development/product, quality and reliability engineering.

4.3. Acceptance

Acceptance is based on verification that the product meets the requirements of Figure 1. Failures attributed to equipment, test setup or operator deficiencies shall not disqualify the product. If product failure occurs, corrective action shall be taken and specimens resubmitted for qualification. Testing to confirm corrective action is required before resubmittal.

4.4. Quality Conformance Inspection

The applicable quality inspection plan shall specify the sampling acceptable quality level to be used. Dimensional and functional requirements shall be in accordance with the applicable product drawing and this specification.

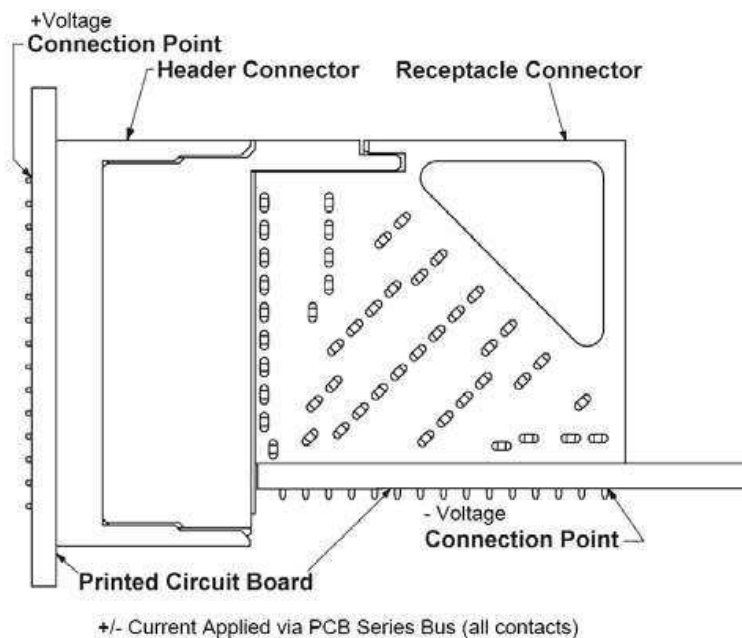

Figure 3
LLRC Measurement Points

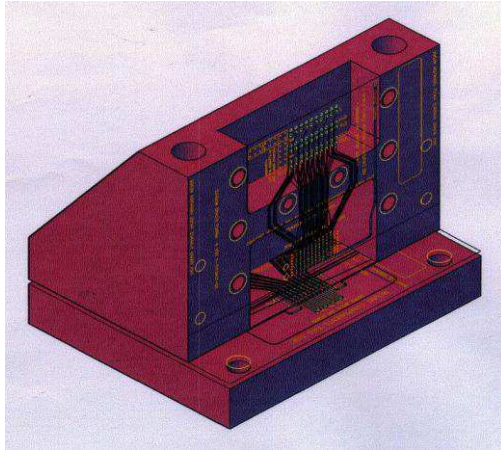

Figure 4
Vibration and Mechanical Shock Mounting Fixture

Row	Left Waflet		Right Waflet	
	Electrical Lengths [mm]	Bulk Resistance [mΩ]	Electrical Lengths [mm]	Bulk Resistance [mΩ]
A	GND	6.9	16.4	10.5
B	19.0	11.9	17.9	11.6
C	19.9	12.5	GND	7.5
D	GND	8.3	21.6	13.1
E	25.2	13.9	23.4	13.7
F	26.0	14.9	GND	8.9
G	GND	8.6	27.7	16.9
H	31.4	16.5	29.5	17.1
J	32.0	17.6	GND	11.0
K	GND	10.5	33.8	19.7
L	37.4	19.0	35.6	19.7
M	38.1	19.1	GND	11.1
N	GND	10.4	40.0	21.3
O	43.6	20.9	41.8	21.7
P	44.4	21.8	GND	11.3
R	GND	11.0	46.1	22.7
S	49.9	23.1	47.9	24.0
T	50.6	22.4	GND	13.7



NOTE

1. Electrical lengths are measured from receptacle compliant pin to header compliant pin.
2. The chart represents values for conventional right angle receptacles to vertical headers.

Figure 5
Signal Contact Typical Initial Bulk Resistances

Product Type	Screw Type	Board Thickness	Recommended Torque
Backplane Headers 2P through 6P	2-56 Machine Screw	6.5 mm max	2.0 in-lbs
Daughtercard Receptacles 2P	2-32 Self-Tapping Screw	1.8 to 2.4 mm	1.0 in-lbs
Daughtercard Receptacles Standard 3P	2-32 Self-Tapping Screw	1.9 to 2.5 mm	1.5 in-lbs
Daughtercard Receptacles Ortho 3P	2-32 Self-Tapping Screw	2.4 mm max	1.0 in-lbs
Daughtercard Receptacles 4P through 6P	2-32 Self-Tapping Screw	4.4 mm max	2.0 in-lbs
Mezzanine Receptacles 3P through 5P	2-32 Self-Tapping Screw	4.4 mm max	2.0 in-lbs
Ram Headers 2P	2-32 Self-Tapping Screw	4.0 mm max	1.0 in-lbs
Ram Headers 3P	2-32 Self-Tapping Screw	4.4 mm max	1.5 in-lbs
Ram Headers 4P through 6P	2-32 Self-Tapping Screw	4.4 mm max	2.0 in-lbs

NOTE

The thread forming screws used for the Daughtercard guidance modules will require varying torque to seat the screw, dependent upon the screw engagement in the module. The screw length and the PCB thickness will both impact the screw engagement into the module. It is recommended that the torque applied be the minimum necessary to fully seat the screw for the specific application. For applications in which the board thickness exceeds the listed recommendations, testing should be conducted to confirm that 1.0 in-lbs of torque can successfully be applied.

Figure 6
Torque Specifications for Mounting Screws