

spec ref	-	dr	Jackie Huang	2014/10/31	projection	MM	size	A2	scale	5:1		
tolerance std	ISO 406 ISO 1101	eng	Sunny2 Liu	2019/03/04			ecn no	ELX-DG-28377-1				
TOLERANCES UNLESS OTHERWISE SPECIFIED		chr	Feng Zheng	2019/03/05			rel level	Released				
		appr	Zheng, Pei-Min	2019/03/05			product family	CARD EDGE				
surface	ISO 1302	linear	0.X	±0.5	<b>Amphenol FCI</b>		title HPCE MEZZANINE UNIVERSAL P+S		dwg no	10132153	rev	C
			0.XX	±0.25					cat. no.	-	Product - Customer Drw	sheet 1 of 4
		angular	0°	±2°								

CONTACT TYPE	TOP LAYER DESCRIPTION	TABLE I (HPCE / SOLDER TAILS) PLATED THROUGH-HOLE REQUIREMENTS				
		DRILLED HOLE DIAMETER	COPPER THICKNESS	TIN-LEAD THICKNESS	TIN THICKNESS	FINISHED HOLE DIAMETER
SIGNAL	TIN-LEAD	1.10-1.16 (1.15 DRILL)	0.025 - 0.050	0.005 - 0.015	--	0.94 - 1.10
	IMMERSION TIN	1.10-1.16 (1.15 DRILL)	0.025 - 0.050	--	0.9 - 1.5um	0.94 - 1.10
	COPPER	1.10-1.16 (1.15 DRILL)	0.025 - 0.050	--	--	0.94 - 1.10

CONTACT TYPE		TABLE I (HPCE / PRESS-FIT TAILS) PLATED THROUGH-HOLE REQUIREMENTS				
		DRILLED HOLE DIAMETER	COPPER THICKNESS	TIN-LEAD THICKNESS	TIN THICKNESS	FINISHED HOLE DIAMETER
POWER & SIGNAL	TIN-LEAD	0.81-0.86 (0.85 DRILL)	0.025 - 0.050	0.005 - 0.015	--	0.65 - 0.80
	IMMERSION TIN	0.81-0.86 (0.85 DRILL)	0.025 - 0.050	--	0.9 - 1.5um	0.70 - 0.80
	COPPER	0.81-0.86 (0.85 DRILL)	0.025 - 0.050	--	--	0.70 - 0.80

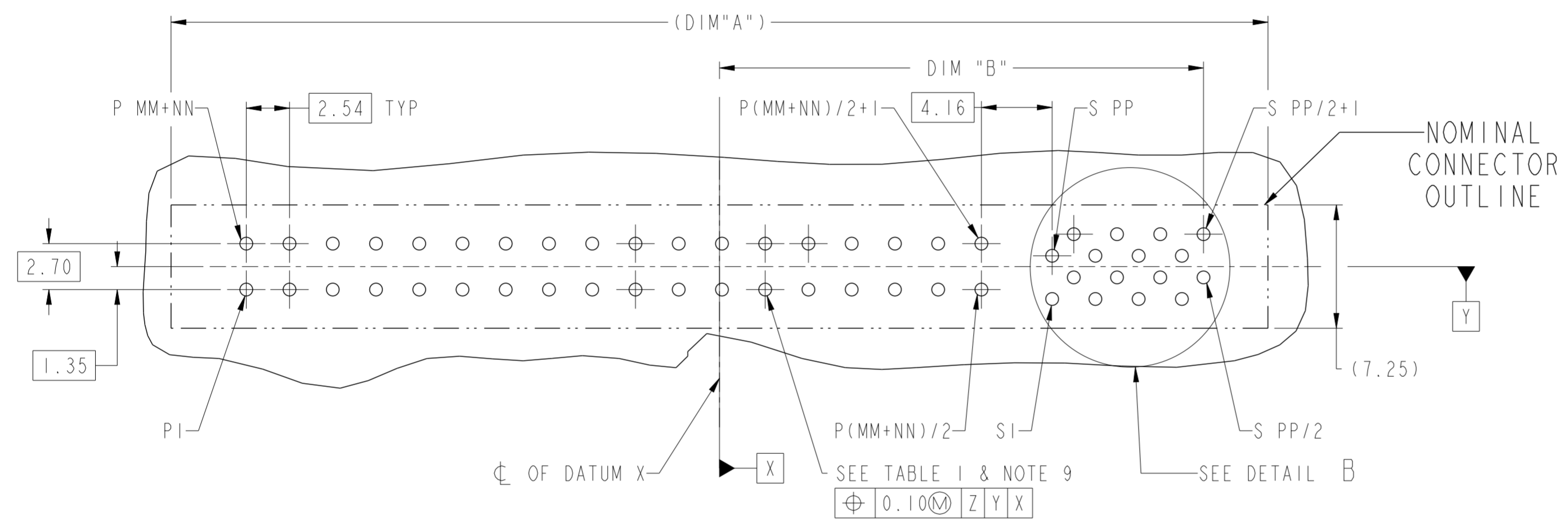

RECOMMENDED HOST BOARD LAYOUT

RECOMMENDED PCB LAYOUT VIEWED FROM CONNECTOR SIDE

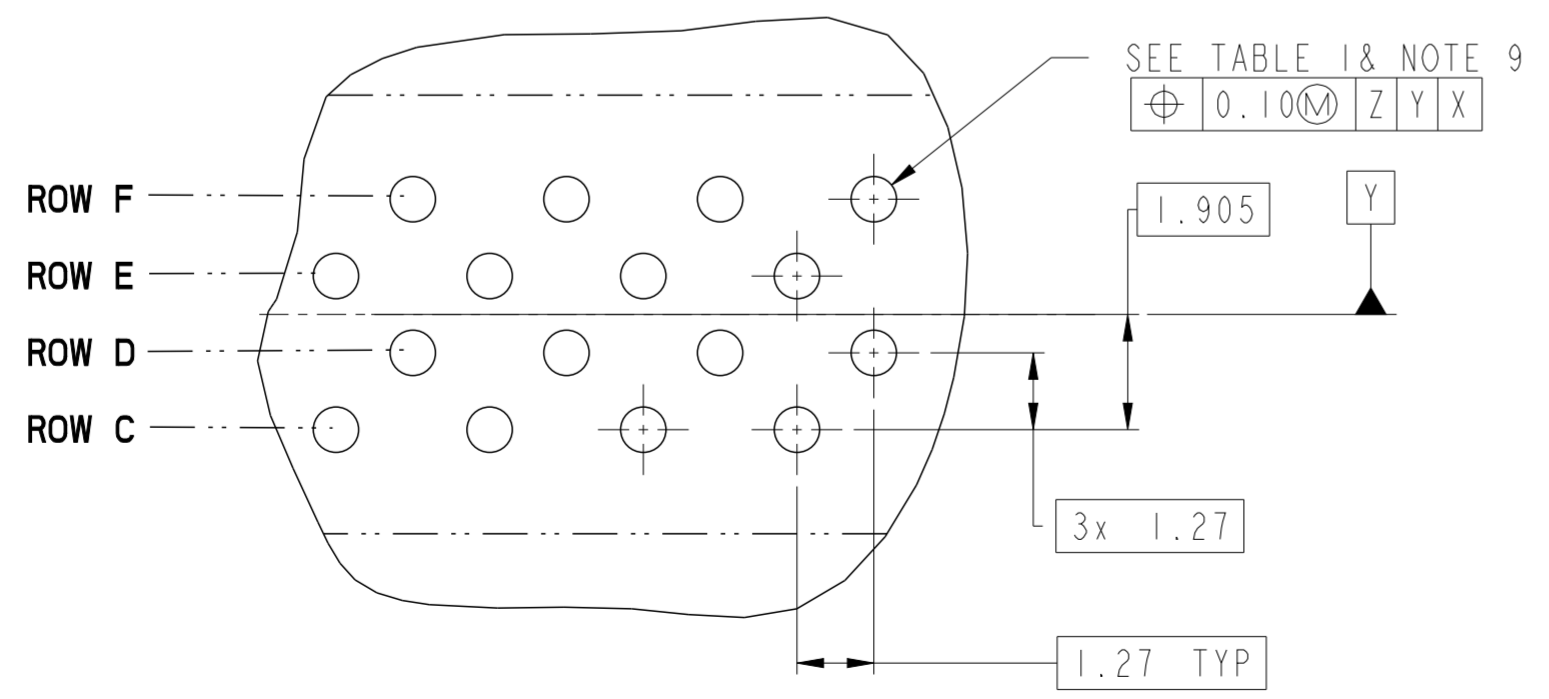
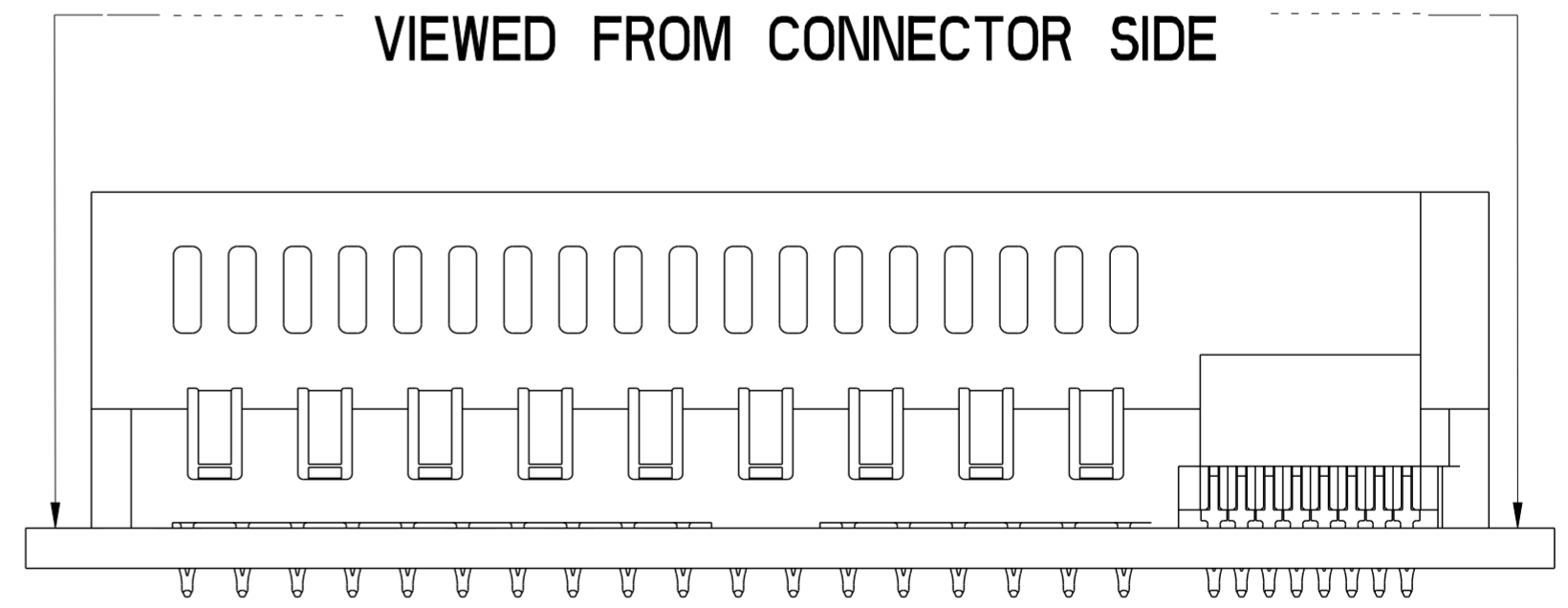

DETAIL B  
SCALE 8:1

spec ref	-	dr	Jackie Huang	2014/10/31	projection	MM	size	A2	scale	2:1
tolerance std	ISO 406 ISO 1101	eng	Sunny2 Liu	2019/03/04			ecn no	ELX-DG-28377-1		
TOLERANCES UNLESS OTHERWISE SPECIFIED		chr	Feng Zheng	2019/03/05				rel level	Released	
surface	linear	0.X	±0.5	0.XX	±0.25	0.XXX	±0.10	Amphenol FCI		
	angular	0°	±2°	HPCE MEZZANINE		UNIVERSAL P+S		cat. no.	Product - Customer Drw	sheet 2 of 4

DIM "L" (±0.25)	MEZZANINE STACK HEIGHT (±0.50)
21.02	32
22.02	33
23.02	34
24.02	35
25.02	36
26.02	37
27.02	38
28.02	39
29.02	40
30.02	41
31.02	42

TABLE 2

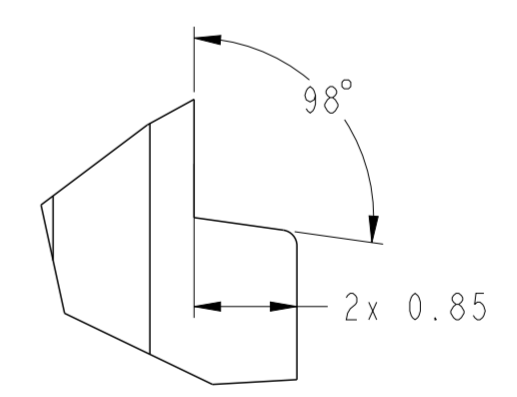
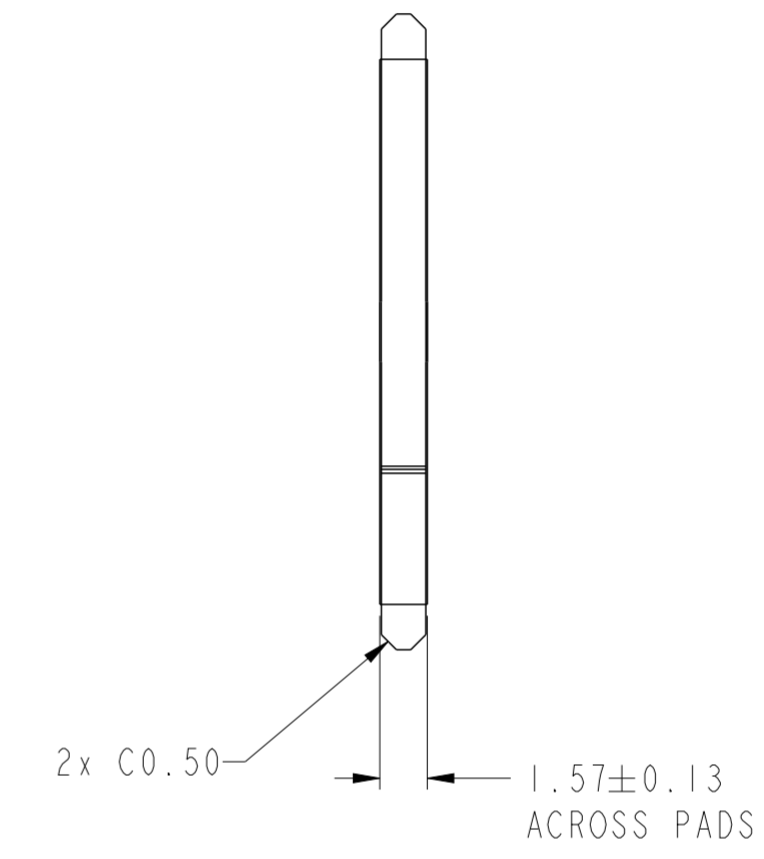
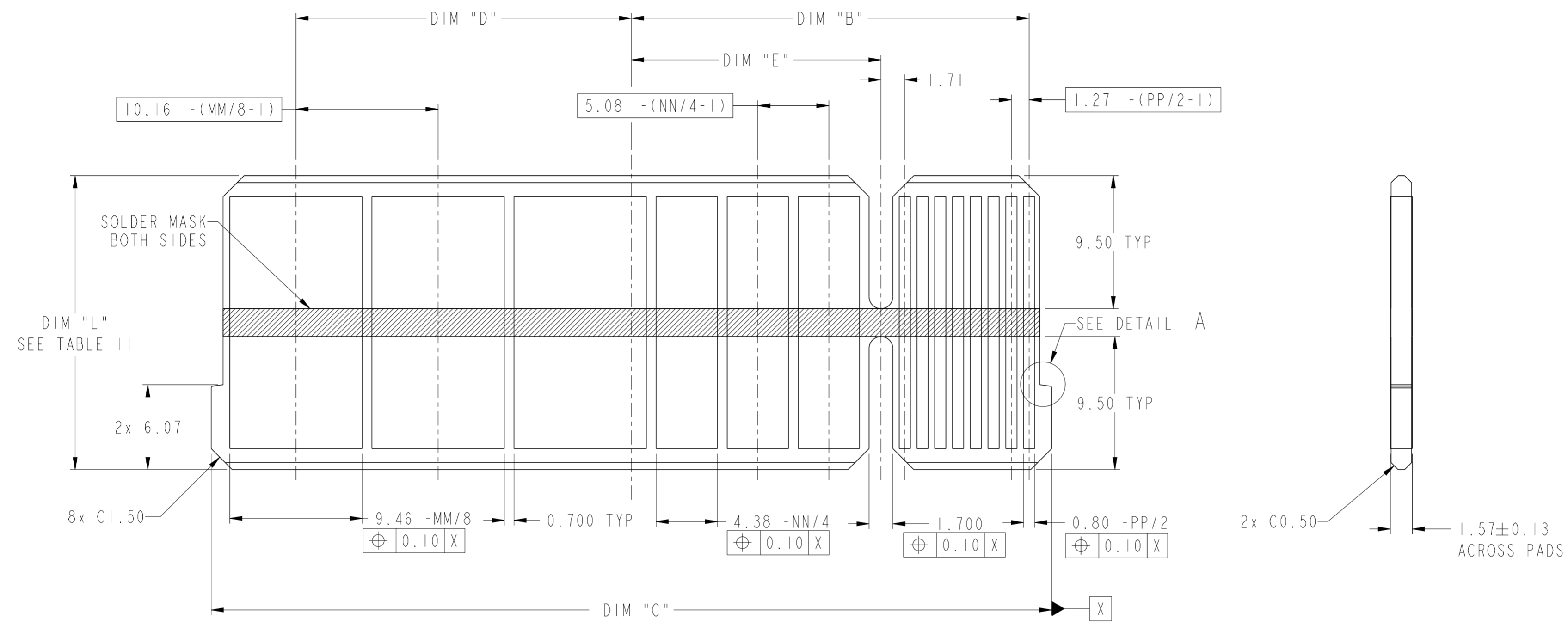

RECOMMENDED BRIDGE PCB

spec ref	-	dr	Jackie Huang	2014/10/31	projection	MM	size	A2	scale	1:1
tolerance std	ISO 406 ISO 1101	eng	Sunny2 Liu	2019/03/04			ecn no	ELX-DG-28377-1	rel level	Released
TOLERANCES UNLESS OTHERWISE SPECIFIED		chr	Feng Zheng	2019/03/05						
		appr	Zheng, Pei-Min	2019/03/05						
surface	linear	0.X	±0.5	0.XX	±0.25	0.XXX	±0.10	angular	0°	±2°
		Amphenol FCI			HPCE MEZZANINE		10132153		rev C	
		UNIVERSAL P+S			cat. no.		Product - Customer Drw		sheet 3 of 4	

PDS: Rev :C

STATUS:Released

Printed: Mar 05, 2019

Amphenol FCI

© 2016 APCI

10132153 - MM NN PP \* LF

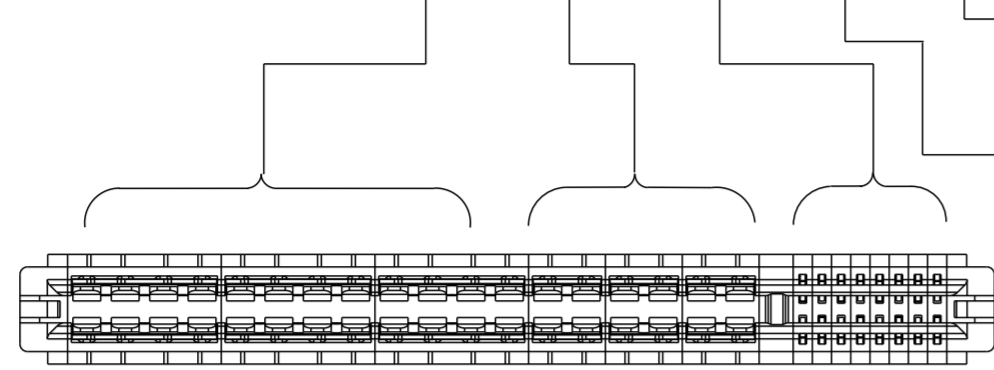

LEAD FREE

	A	B	C	D
ORIENTATION KEY	Y	N	Y	N
TAIL TYPE	PF	PF	STB	STB

Example : The part number above is 10132153-320424ALF  
that's 36P24S with orientation key configuration  
32 is 4beam contact ; 04 is 2beam contact

Table 3 : PART NUMBER CODE

DIM	LENGTH FORMULAS
A	$= [(MM+NN)/2] \times 2.54 + (PP/2) \times 1.27 + 8.55$
B	$= \text{DIM "A"} / 2 - 3.79$
C	$= \text{DIM "A"} - 4.34$
D	$= \text{DIM "A"} / 2 - 8.23$
E	$= \text{DIM "A"} / 2 - (PP/2 - 1) \times 1.27 - 5.5$

Table 4

Amphenol FCI

NOTES:

- CONNECTOR MATERIALS:  
HOUSING: HIGH TEMPERATURE THERMAL PLASTIC, BLACK  
UL 94V-0 COMPLIANT  
CONTACTS: HIGH PERFORMANCE COPPER ALLOY.
- CONTACT FINISH REF. GS-12-1261 SECTION 5.2.
- PRODUCT SPECIFICATION: GS-12-1261.
- APPLICATION SPECIFICATION: GS-20-128.
- PRODUCT MARKING ON HOUSING IN AREA SHOWN MEETS AFCI SPECIFICATION: GS-24-007.
- PACKAGING MEETS FCI SPECIFICATION GS-14-937.
- HOUSING COMPONENT WILL WITHSTAND EXPOSURE TO 260°C PEAK TEMPERATURE FOR 60 SECONDS IN A CONVECTION, INFRA-RED, OR VAPOR PHASE REFLOW OVEN.
- COPPER PLATING THICKNESS IN CENTER OF VIA-HOLE CAN BE NO MORE THAN 0.003 LESS THAN OTHER AREAS.
- ALL HOLE SIZES ARE FINISHED HOLE SIZES.
- A SYMBOL WILL BE NEXT TO ANY DIMENSION, VIEW, OR NOTE WHICH HAS BEEN MODIFIED WITH THE CURRENT DRAWING REVISION.

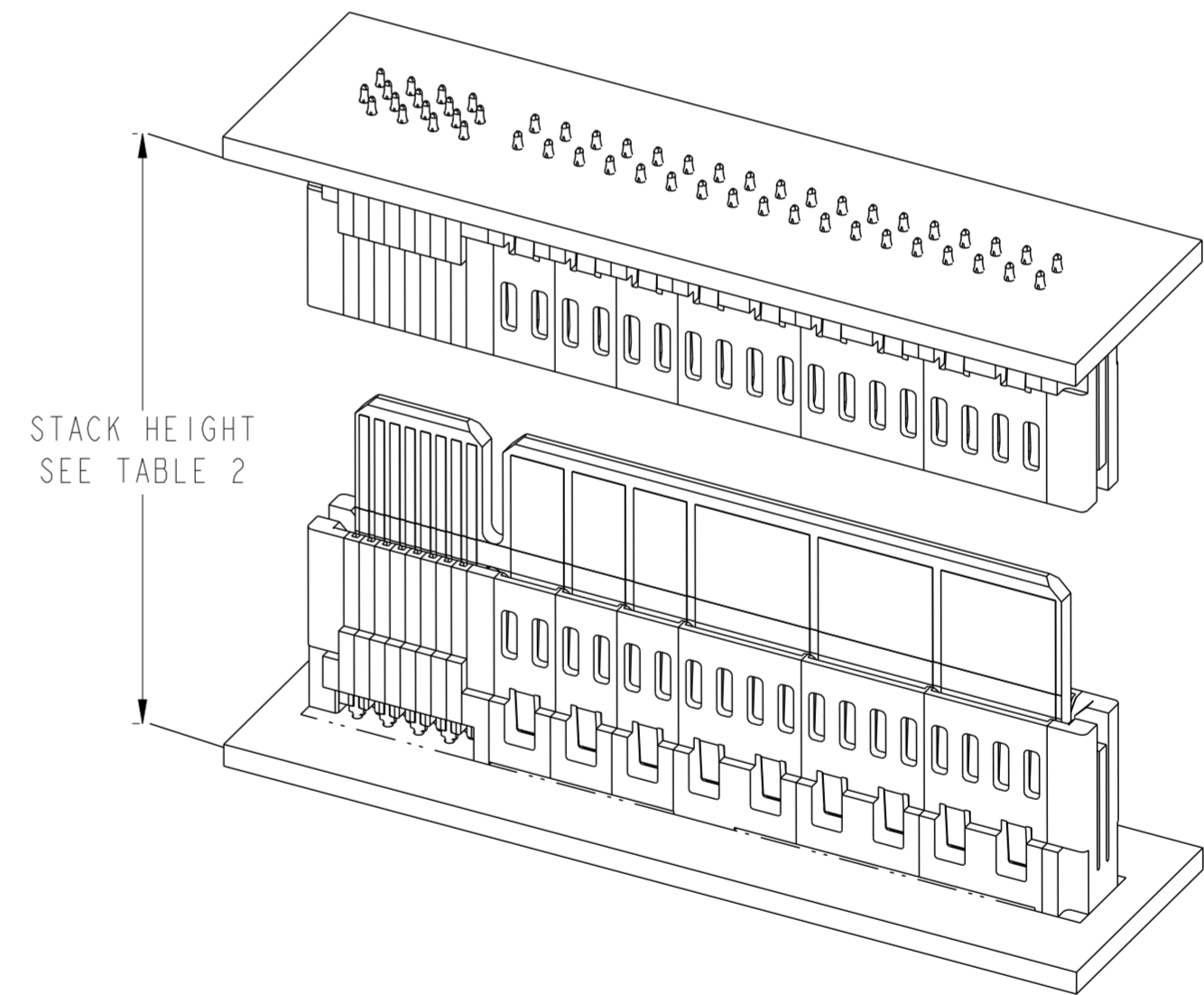

spec ref	-	dr	Jackie Huang	2014/10/31	projection	MM	size	A2	scale	1:1
tolerance std	ISO 406 ISO 1101	eng	Sunny2 Liu	2019/03/04		← →	ecn no	ELX-DG-28377-1		
surface	linear	chr	Feng Zheng	2019/03/05			rel level	Released		
		appr	Zheng, Pei-Min	2019/03/05			product family	-		
	angular	Amphenol FCI		title	HPCE MEZZANINE UNIVERSAL P+S			cat. no.	Product - Customer Drw	sheet 4 of 4

PDS: Rev :C

STATUS:Released

Printed: Mar 05, 2019