

# San Ace 150W 9W2T type

## Splash Proof Centrifugal Fan

### Features

#### Water and Dust Resistance

Its IP68-rated\* water and dust protection ensures stable fan operation even in harsh environments.

#### High Airflow and High Static Pressure

This fan delivers a maximum airflow of 3.83 m<sup>3</sup>/min and a maximum static pressure of 390 Pa.

#### High Energy Efficiency and Low Noise

The PWM control function enables the external control of fan speed, contributing to lowering noise and improving energy efficiency of devices.

\*The degree of protection (IP code) is defined by IEC 60529 (International Electrotechnical Commission).  
IP68:  
 • Completely protected against dust  
 • Protected against submersion in water

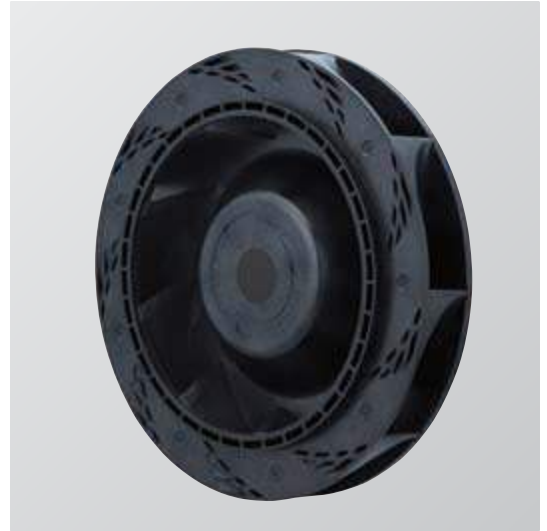

∅150 × 35 mm

### Specifications When the optional inlet nozzle (109-1081H) is mounted.

The models listed below **have pulse sensors with PWM control function.**

Model no.	Rated voltage [V]	Operating voltage range [V]	PWM duty cycle* [%]	Rated current [A]	Rated input [W]	Rated speed [min <sup>-1</sup> ]	Max. airflow [m <sup>3</sup> /min] [CFM]	Max. static pressure [Pa] [inchH <sub>2</sub> O]	SPL [dB(A)]	Operating temperature [°C]	Expected life [h]
9W2TN24P1H001	24	20.4 to 27.6	100	0.64	15.4	3800	3.83 135	390 1.57	59	-20 to +70	40000/60°C (70000/40°C)
			20	0.16	3.84	1500	1.51 53	60.7 0.24	38		
9W2TN48P1H001	48	36 to 55.2	100	0.32	15.4	3800	3.83 135	390 1.57	59		
			20	0.08	3.84	1500	1.51 53	60.7 0.24	38		

\* PWM frequency: 25 kHz. Fan does not rotate when PWM duty cycle is 0%.  
Max input is 22 W at rated voltage.

### Common Specifications

- Material ..... Motor case: Aluminum (Black coating), Impeller: Plastic (Flammability: UL 94V-0)
- Expected life ..... Refer to specifications  
(L10 life: 90% survival rate for continuous operation in indoor free air at 60°C, rated voltage)  
Expected life at 40°C is for reference only.
- Motor protection system ..... Current blocking function and reverse polarity protection
- Dielectric strength ..... 50/60 Hz, 500 VAC, for 1 minute (between lead wire conductors and motor case)
- Sound pressure level (SPL) ..... At 1 m away from the air inlet
- Operating temperature ..... Refer to specifications (Non-condensing)
- Storage temperature ..... -30 to +70°C (Non-condensing)
- Lead wire ..... ⊕ Red ⊖ Black Sensor Yellow Control Brown
- Mass ..... Approx. 360 g
- Ingress protection ..... IP68

## Airflow - Static Pressure Characteristics

• PWM duty cycle

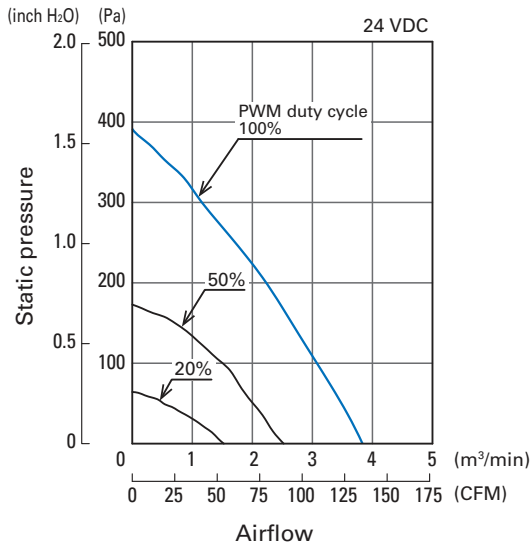

9W2TN24P1H001

• Operating voltage range

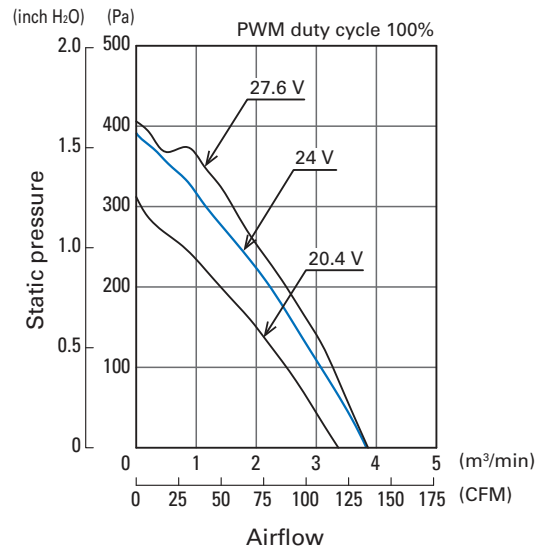

9W2TN24P1H001

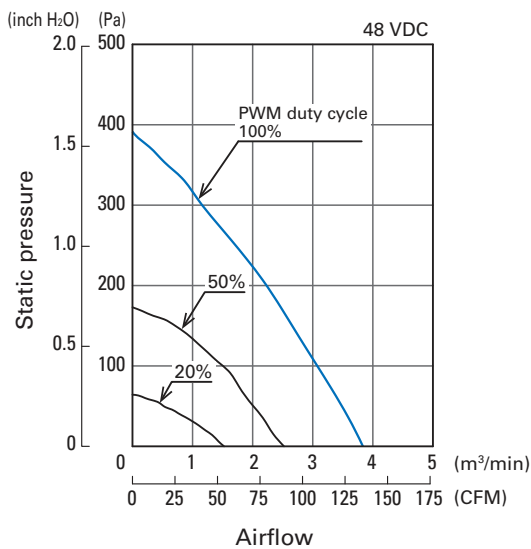

9W2TN48P1H001

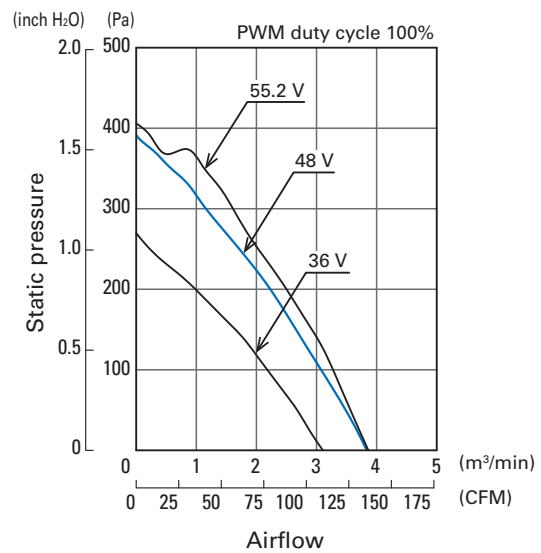

9W2TN48P1H001

## PWM Duty - Speed Characteristics Example

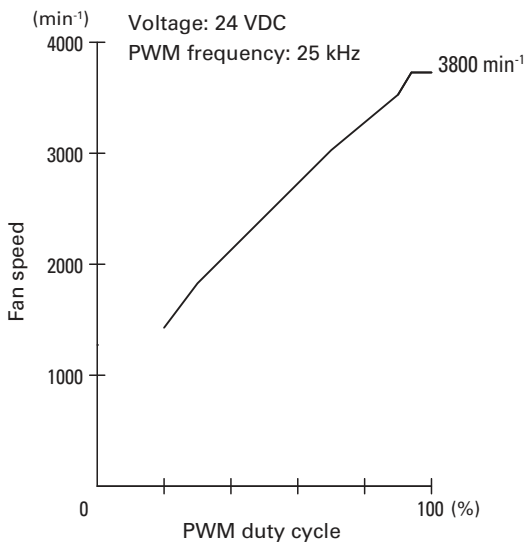

9W2TN24P1H001

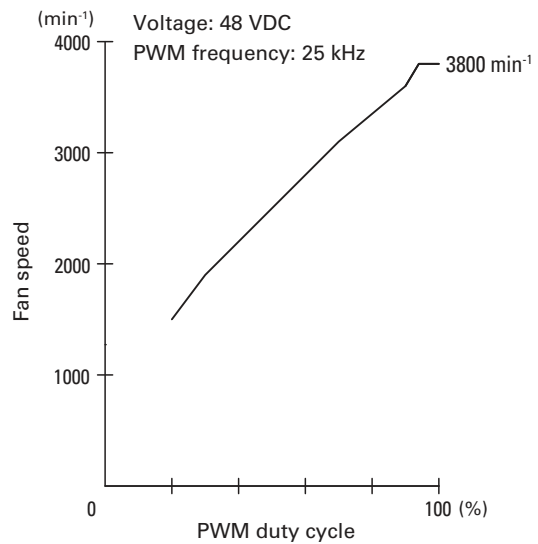

9W2TN48P1H001

### PWM Input Signal Example

Input signal waveform

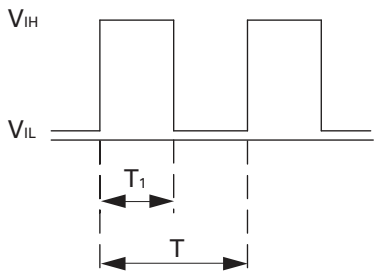

$V_{IH} = 4.75 \text{ to } 5.25 \text{ V}$     $V_{IL} = 0 \text{ to } 0.4 \text{ V}$   
 PWM duty cycle (%) =  $\frac{T_1}{T} \times 100$    PWM frequency 25 (kHz) =  $\frac{1}{T}$   
 Current source ( $I_{source}$ ) = 2 mA max. (when control voltage is 0 V)  
 Current sink ( $I_{sink}$ ) = 1 mA max. (when control voltage is 5.25 V)  
 Control terminal voltage = 5.25 V max. (when control terminal is open)

When the control terminal is open,  
 fan speed is the same as when PWM duty cycle is 100%.  
 Either TTL input, open collector or open drain can be used for  
 PWM control input signal.

### Example of Connection Schematic

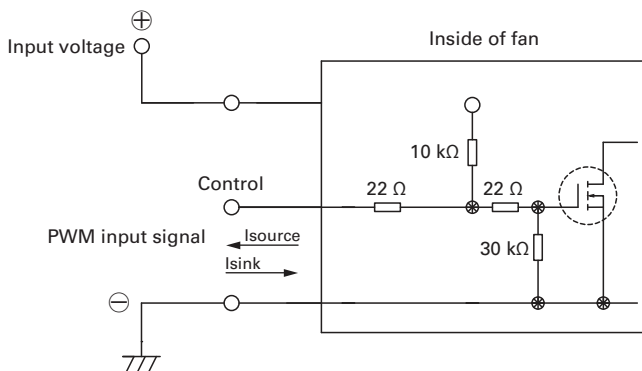

### Specifications for Pulse Sensors

Output circuit: Open collector

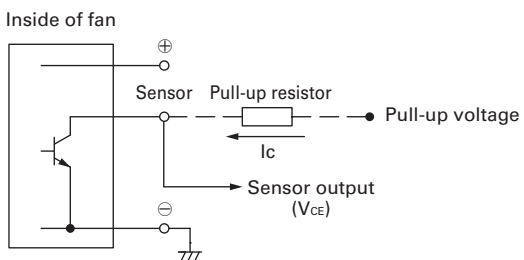

**Rated voltage 24 V fan**  
 $V_{CE} = +30 \text{ V max.}$   
 $I_c = 10 \text{ mA max. [} V_{OL} = V_{CE} \text{ (SAT)} = 0.6 \text{ V max.]}$

**Rated voltage 48 V fan**  
 $V_{CE} = +60 \text{ V max.}$   
 $I_c = 10 \text{ mA max. [} V_{OL} = V_{CE} \text{ (SAT)} = 0.6 \text{ V max.]}$

Output waveform (Need pull-up resistor)

In case of steady running

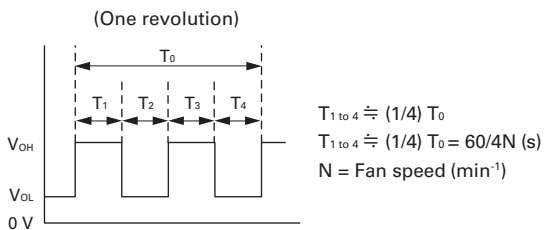

■ Dimensions (unit: mm)

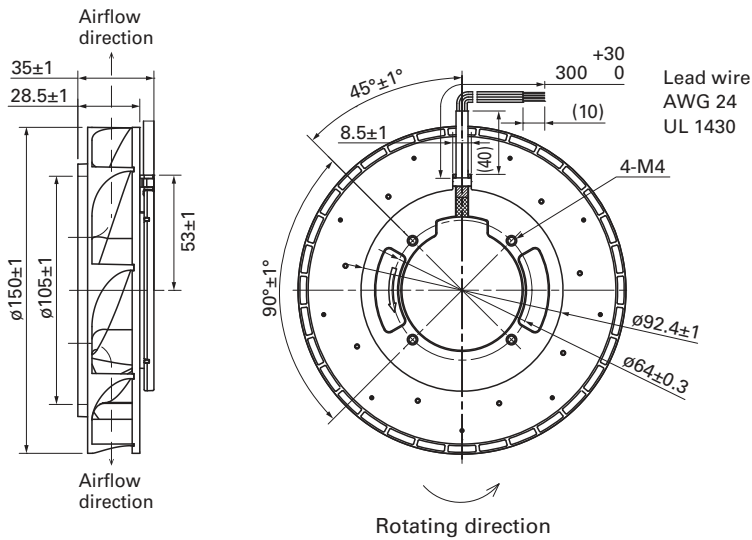

■ Reference Dimensions of Mounting Holes and Vent Opening (unit: mm)

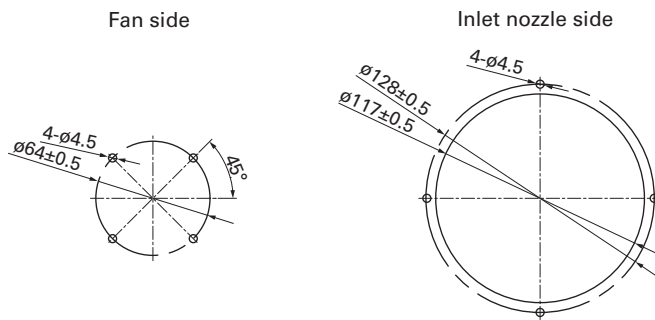

■ Reference Diagram for Mounting

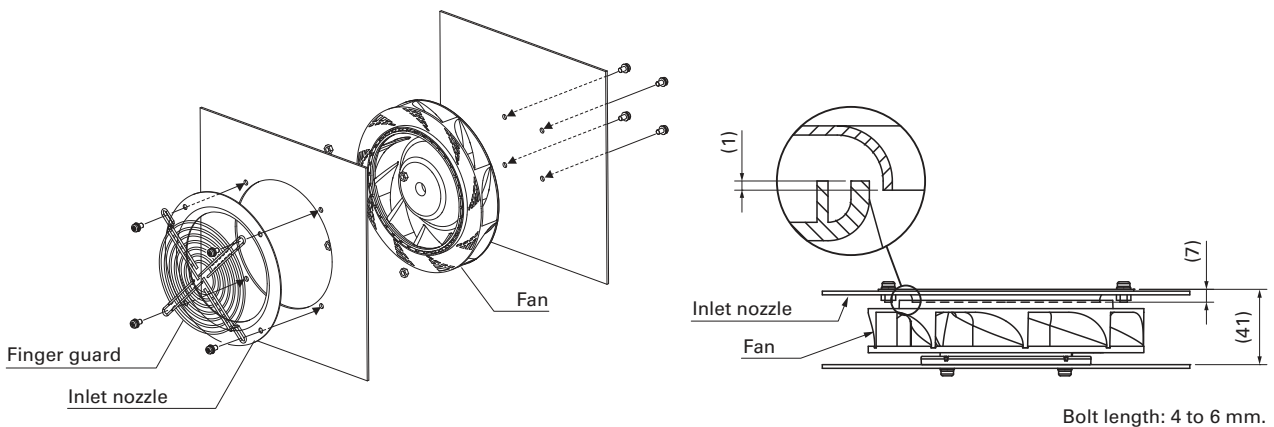

Notice

- Please read the "Safety Precautions" on our website before using the product.
- The products shown in this catalog are subject to Japanese Export Control Law. Diversion contrary to the law of exporting country is prohibited.
- For protecting fan bearings against electrolytic corrosion near strong electromagnetic noise sources, we provide effective countermeasures such as Electrolytic Corrosion Proof Fans and EMC guards. Contact us for details.

**SANYO DENKI CO.,LTD.**

3-33-1 Minami-Otsuka, Toshima-ku, Tokyo 170-8451, Japan TEL: +81 3 5927 1020

<https://www.sanyodenki.com>

The names of companies and/or their products specified in this catalog are the trade names, and/or trademarks and/or registered trademarks of such respective companies. "San Ace" is a trademark of SANYO DENKI CO.,LTD.

Specifications are subject to change without notice.

CATALOG No. C1091B001 '19.3