

THIS DRAWING IS UNPUBLISHED. RELEASED FOR PUBLICATION 20  
 © COPYRIGHT 20 BY - ALL RIGHTS RESERVED.

| REVISIONS |     |                           |           |       |
|-----------|-----|---------------------------|-----------|-------|
| P         | LTR | DESCRIPTION               | DATE      | APVD  |
| F         |     | REVISED PER ECO-13-019095 | 05DEC2013 | DR RB |

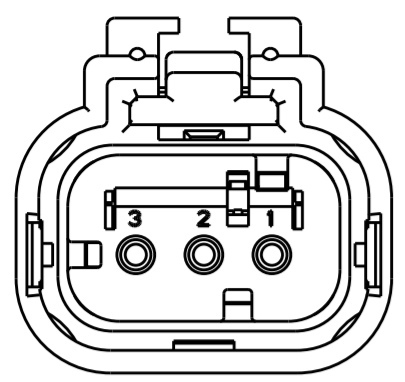

776429-2  
SCALE 2:1  
KEY B

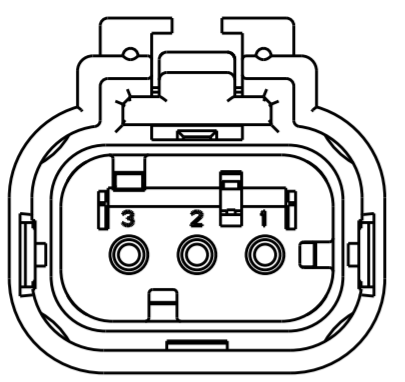

776429-3  
SCALE 2:1  
KEY C

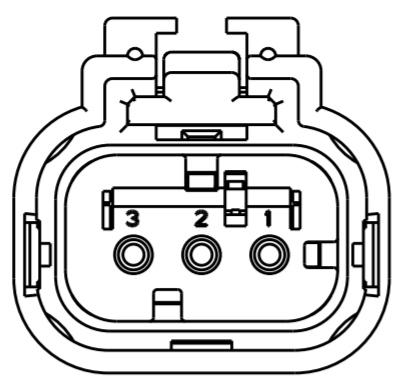

776429-4  
SCALE 2:1  
KEY D

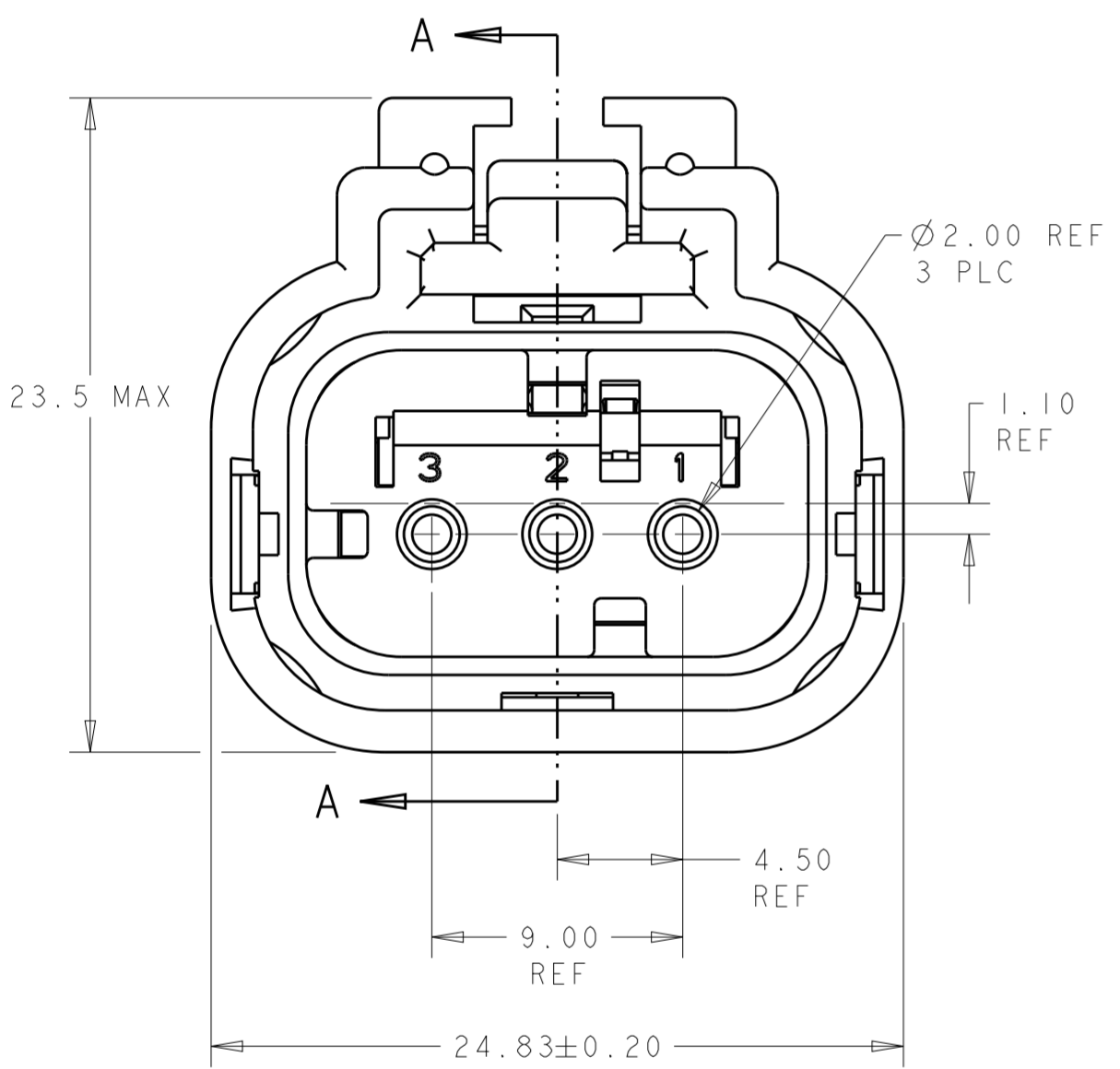

776429-1 SHOWN  
KEY A

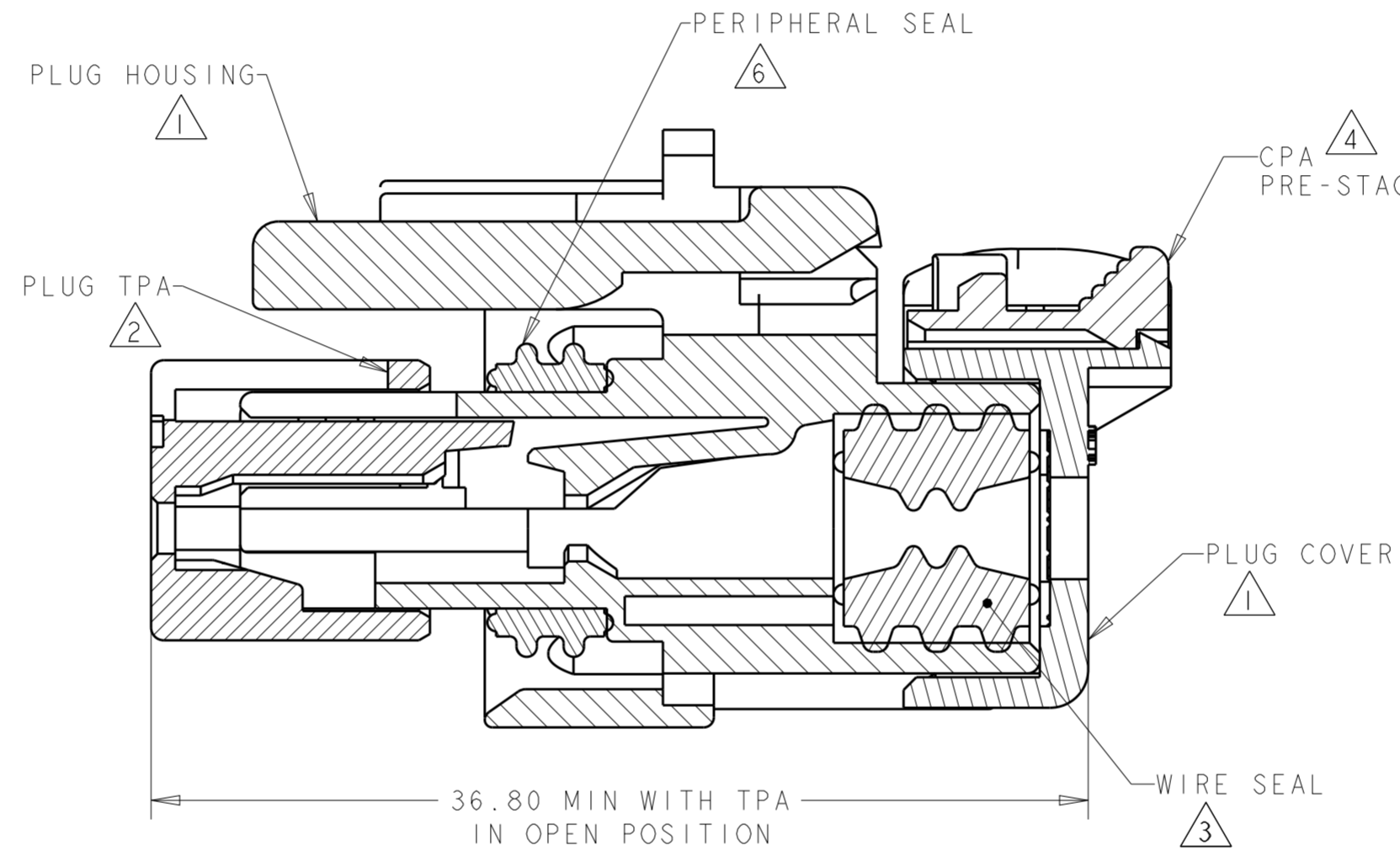

SECTION A-A

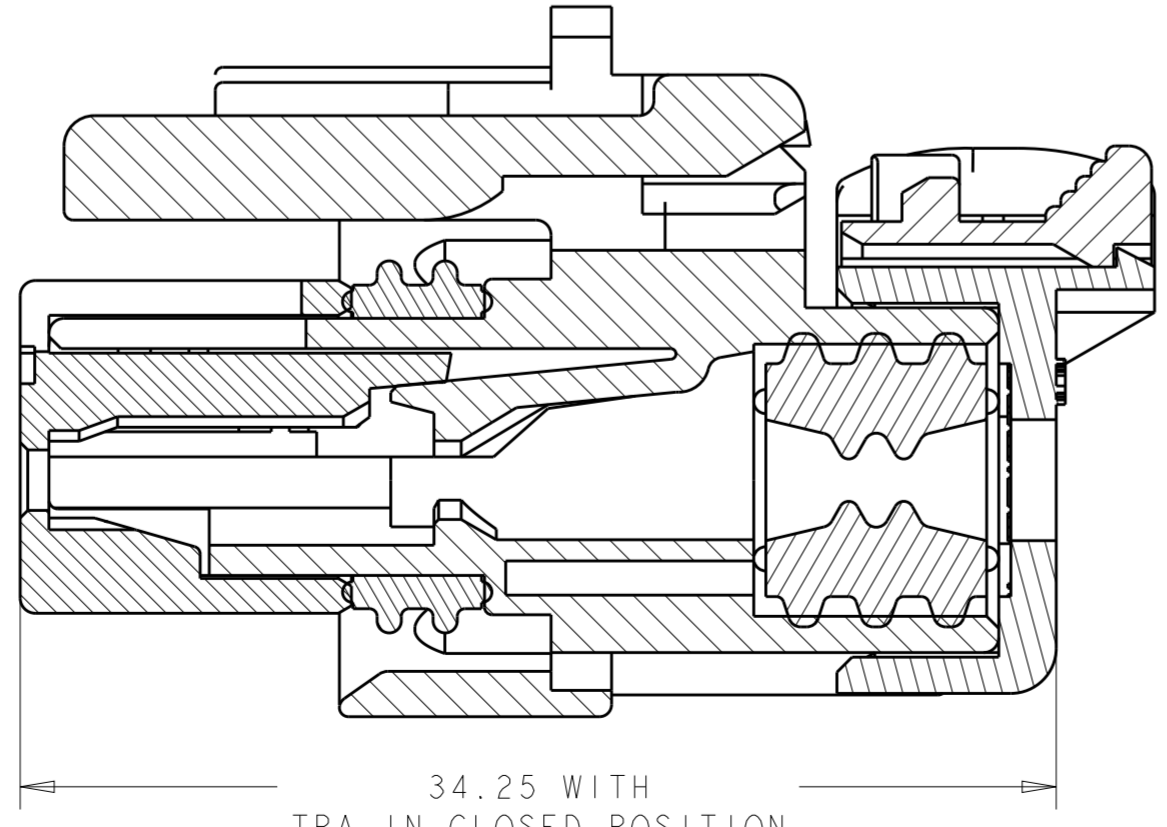

SECTION A-A

- 1 MATERIAL: 15% GLASS FILLED THERMOPLASTIC  
COLOR: BLACK
- 2 MATERIAL: 15% GLASS FILLED THERMOPLASTIC  
COLOR: (SEE TABLE)
- 3 MATERIAL: SILICONE  
COLOR: GREEN
- 4 MATERIAL: 15% GLASS FILLED THERMOPLASTIC  
COLOR: RED
- 5. RECOMMENDED WIRE DIAMETER RANGE IS 2.18 TO 3.67mm.
- 6 MATERIAL: SILICONE  
COLOR: TAN

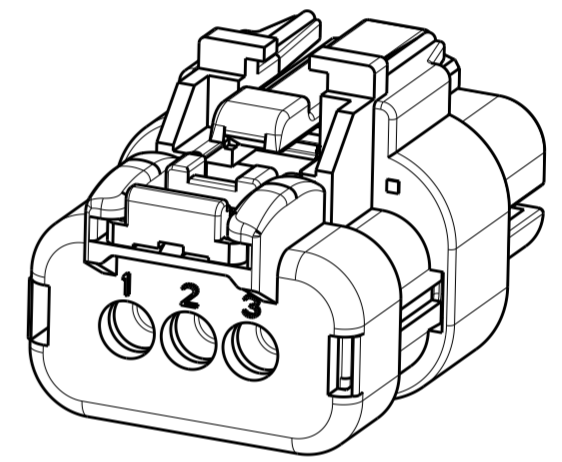

SCALE 2:1

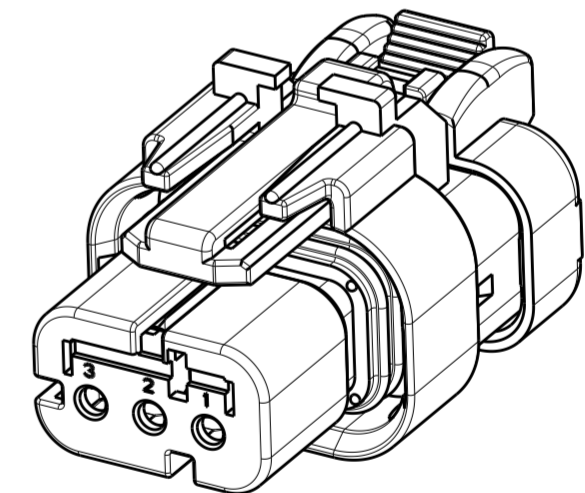

SCALE 2:1

|     |           |             |
|-----|-----------|-------------|
| D   | GREEN     | 776429-4    |
| C   | YELLOW    | 776429-3    |
| B   | GRAY      | 776429-2    |
| A   | RED       | 776429-1    |
| KEY | TPA COLOR | PART NUMBER |

|   |   |                               |  |       |   |       |   |       |   |       |   |        |   |        |   |                          |                 |  |
|---|---|-------------------------------|--|-------|---|-------|---|-------|---|-------|---|--------|---|--------|---|--------------------------|-----------------|--|
| THIS DRAWING IS A CONTROLLED DOCUMENT.  |   | DWN<br>AJ GRAFF 22FEB00       | TE Connectivity  |       |   |       |   |       |   |       |   |        |   |        |   |                          |                 |  |
| DIMENSIONS:<br>mm   |   | CHK<br>R GREINER 11DEC01      |  |       |   |       |   |       |   |       |   |        |   |        |   |                          |                 |  |
| TOLERANCES UNLESS OTHERWISE SPECIFIED:  |   | APVD<br>M TRULLI 11DEC01      | NAME<br>PLUG ASSEMBLY,<br>3 POSITION, SINGLE ROW<br>AMPSEAL 16 |       |   |       |   |       |   |       |   |        |   |        |   |                          |                 |  |
| <table border="1"> <tr><td>0 PLC</td><td>±</td></tr> <tr><td>1 PLC</td><td>±</td></tr> <tr><td>2 PLC</td><td>±</td></tr> <tr><td>3 PLC</td><td>±</td></tr> <tr><td>4 PLC</td><td>±</td></tr> <tr><td>ANGLES</td><td>±</td></tr> <tr><td>FINISH</td><td>-</td></tr> </table> |   | 0 PLC                         | ±  | 1 PLC | ± | 2 PLC | ± | 3 PLC | ± | 4 PLC | ± | ANGLES | ± | FINISH | - | PRODUCT SPEC<br>108-2184 | SIZE<br>A200779 |  |
| 0 PLC   | ± |                               |  |       |   |       |   |       |   |       |   |        |   |        |   |                          |                 |  |
| 1 PLC   | ± |                               |  |       |   |       |   |       |   |       |   |        |   |        |   |                          |                 |  |
| 2 PLC   | ± |                               |  |       |   |       |   |       |   |       |   |        |   |        |   |                          |                 |  |
| 3 PLC   | ± |                               |  |       |   |       |   |       |   |       |   |        |   |        |   |                          |                 |  |
| 4 PLC   | ± |                               |  |       |   |       |   |       |   |       |   |        |   |        |   |                          |                 |  |
| ANGLES  | ± |                               |  |       |   |       |   |       |   |       |   |        |   |        |   |                          |                 |  |
| FINISH  | - |                               |  |       |   |       |   |       |   |       |   |        |   |        |   |                          |                 |  |
| MATERIAL  |   | APPLICATION SPEC<br>114-13065 | DRAWING NO<br>C-776429   |       |   |       |   |       |   |       |   |        |   |        |   |                          |                 |  |
|   |   | WEIGHT<br>10                  | RESTRICTED TO  |       |   |       |   |       |   |       |   |        |   |        |   |                          |                 |  |
|   |   | Customer Drawing              | SCALE 4:1 SHEET OF REV F                                       |       |   |       |   |       |   |       |   |        |   |        |   |                          |                 |  |