

WITH MOUNTING CLIPS

8:1

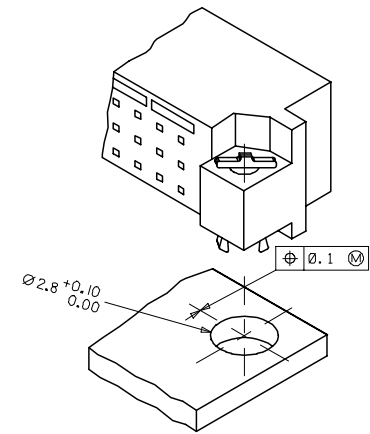

RECOMMENDED PCB LAYOUT  
COMPONENT SIDE

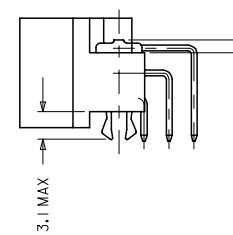
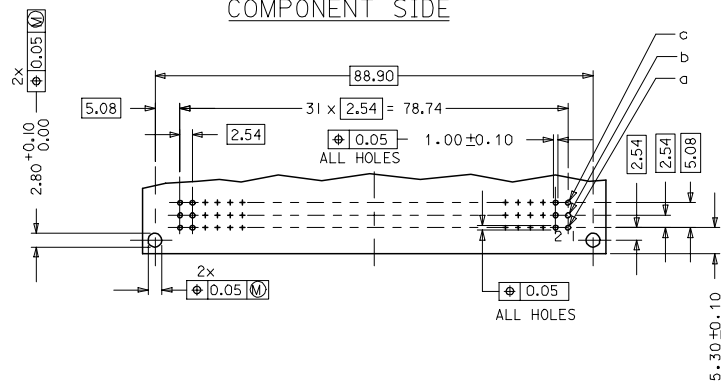

NOTES:

- 1) MATERIALS: PCT, CLASS FILLED,  
UL94V-0, COLOUR: NATURAL  
TERMINAL - BRASS  
MOUNTING CLIP: STEEL
- 2) FINISH: TERMINAL:-  
CONTACT AREA
  1. PERFORMANCE LEVEL 1: SELECTIVE GOLD (Au), THICKNESS = 1.1 MICROMETER  
OVER NICKEL, THICKNESS = 1.25 MICROMETER
  2. PERFORMANCE LEVEL 2: SELECTIVE GOLD (Au), THICKNESS = 0.6 MICROMETER  
OVER NICKEL, THICKNESS = 1.25 MICROMETER
  3. PERFORMANCE LEVEL 3: SELECTIVE GOLD (Au), THICKNESS = 0.3 MICROMETER  
OVER NICKEL, THICKNESS = 1.25 MICROMETER
 TERMINATION AREA:  
SELECTIVE TIN, THICKNESS = 2.5 MICROMETER  
OVER NICKEL, THICKNESS = 1.25 MICROMETER OVERALL
- 3) MOUNTING CLIP:-  
TIN (Sn), THICKNESS = 5-10 MICROMETER,  
OVER NICKEL (Ni), THICKNESS = 2.5 MICROMETER
- 4) FOR NON MOUNTING CLIP OPTION, CONNECTOR TO BE SECURED WITH  
RIVETS: 2 TUBULAR RIVETS 2.5 x 0.3 ... DIN 7340  
SCREWS: 2 CHEESEHEAD SCREWS M2.5 x .... DIN 84 AND 2 HEXAGONAL NUTS M2.5 DIN 934
- 5) FOR CUSTOMER PART NO. PRINTING DETAILS  
REFER SHEET 2.
- 6) CUT FACE OF TIP WITHOUT PLATING PERMITTED
- 7) PRODUCT SPECIFICATION PS : 36502-002

RoHS COMPLIANT

ENTER DESCRIPTION ELC.MC.12007.0261 DRWINGATTI/MARAD 2007/01/18 CH/CK/PRASAD 2007/01/19 APPROX/PRASAD 2007/01/19	QUALITY SYMBOLS ▽=0 ▽=0	GENERAL TOLERANCES (UNLESS SPECIFIED)		DIMENSION STYLE MM ONLY		SCALE 2:1	DESIGN UNITS METRIC	THIRD ANGLE PROJECTION
		mm	INCH	DRAWN BY	DATE	TITLE	ASSY DIN41612 96 POS C MALE, HIGH TEMP CONN. CUSTOMER SPECIAL PRINT	
DRAFT WHERE APPLICABLE MUST REMAIN WITHIN DIMENSIONS	SEE SHEET 2	DRAFT WHERE APPLICABLE MUST REMAIN WITHIN DIMENSIONS		DIMENSION STYLE MM ONLY		MATERIAL NO. SD-36502-020 DOCUMENT NO. SD-36502-020		
		SEE SHEET 2		MATERIAL NO. SD-36502-020 DOCUMENT NO. SD-36502-020		SHEET NO. 1 OF 2		

MATERIAL No	PERF LEVEL	PLATING	CONTACT SEQUENCE/ROW	PREMATING CONTACT POS.	MOUNTING CLIP
36502-0134	3	Au+NI	1,2,3,...32 a+b+c	N0	YES

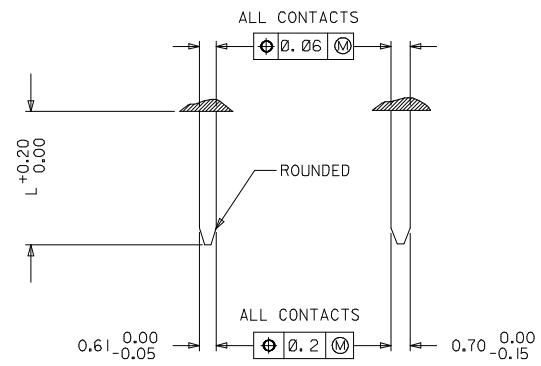

PRE MATING CONTACTS	5.4
NORMAL CONTACTS	4.8
	L

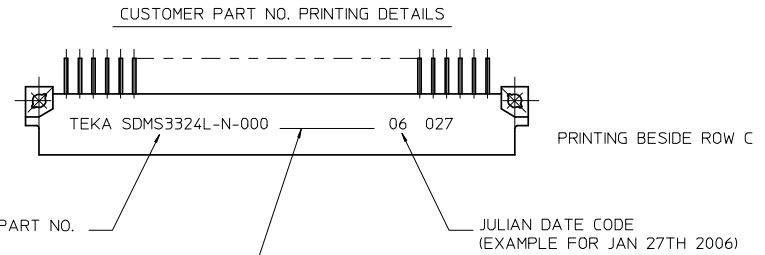

THIS UNDER LINE IS BLANK SPACE OF 19MM APPROXIMATELY TO ACHIEVE THIS GAP LEAVE THE SPACE OF 12 LETTERS

RoHS COMPLIANT

<b>ENTER DESCRIPTION</b> E.C. NO: 12008-0404 DRAWNS: 2008/03/03 CHKDR:KPRASAD 2008/03/03 APPR:KPRASAD 2008/03/03 A3	<b>QUALITY SYMBOLS</b> ▽=0 ▽=0	<b>GENERAL TOLERANCES (UNLESS SPECIFIED)</b>		<b>DIMENSION STYLE</b> MM ONLY	SCALE 2:1	DESIGN UNITS METRIC	THIRD ANGLE PROJECTION		
		4 PLACES ± --- ± --- 3 PLACES ± 0.05 ± --- 2 PLACES ± 0.1 ± --- 1 PLACE ± 0.15 ± ---	mm INCH	DRAWN BY SHANKAR	DATE 2006/05/30	TITLE ASSY DIN41612 96 POS C MALE, HIGH TEMP CONN. CUSTOMER SPECIAL PRINT			
		ANGULAR ± 2 °	DRAFT WHERE APPLICABLE MUST REMAIN WITHIN DIMENSIONS	CHECKED BY SSUDHIR	DATE 2006/05/30	MOLEX INCORPORATED			
		SEE CHART	MATERIAL NO. SD-36502-020	APPROVED BY SSUDHIR	DATE 2006/05/30	DOCUMENT NO.	SHEET NO. 2 OF 2		

THIS DRAWING CONTAINS INFORMATION THAT IS PROPRIETARY TO MOLEX INCORPORATED AND SHOULD NOT BE USED WITHOUT WRITTEN PERMISSION