

DETAIL A  
SCALE 4:1  
DIMENSIONS FOR SELECTIVE  
PLATING'S

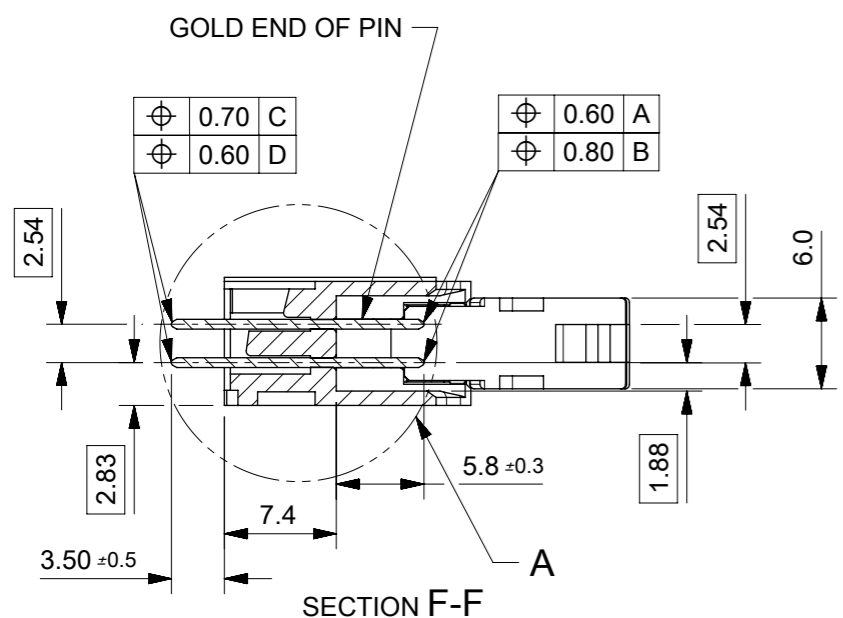

- NOTES:**
1. FOR MATERIAL SPECIFICATION SEE NOTE 1. ON SHEET 2.
  2. FOR RECOMMENDED P.C.B. HOLE PATTERN, PART NO'S AND UNSTATED DIMENSIONS SEE SHHET 2.
  3. PRODUCT SPEC. NO.: PS-99020-0015

|   |        |                                 |            |                          |                 |
|---|--------|---------------------------------|------------|--------------------------|-----------------|
| THIS DRAWING CONTAINS INFORMATION THAT IS PROPRIETARY TO MOLEX ELECTRONIC TECHNOLOGIES, LLC AND SHOULD NOT BE USED WITHOUT WRITTEN PERMISSION |        | CURRENT REV DESC: CAD MIGRATION |            | <b>molex</b>             |                 |
| DIMENSION UNITS   | SCALE  |                                 |            |                          |                 |
| mm  | 2:1    |                                 |            | PRODUCT CUSTOMER DRAWING |                 |
| GENERAL TOLERANCES (UNLESS SPECIFIED)   |        | EC NO: 605552                   |            | DOCUMENT NUMBER          |                 |
| ANGULAR TOL   | ± 0.5° | DRWN: EEGBEDIRE                 | 2018/12/12 | SDA-90571                |                 |
| 4 PLACES  | ±      | CHK'D: TTOURISH                 | 2019/04/15 | DOC TYPE                 | DOC PART        |
| 3 PLACES  | ±      | APPR: DMAHER                    | 2019/04/15 | PSD                      | 001             |
| 2 PLACES  | ± 0.15 | INITIAL REVISION:               |            | REVISION                 |                 |
| 1 PLACE   | ± 0.2  | DRWN: SM                        | 03/08/1990 | H1                       |                 |
| 0 PLACES  | ±      | APPR: EFOLAN                    | 2010/08/25 |                          |                 |
| DRAFT WHERE APPLICABLE MUST REMAIN WITHIN DIMENSIONS  |        | THIRD ANGLE PROJECTION          | DRAWING    | SERIES                   | MATERIAL NUMBER |
|   |        |                                 | A3-SIZE    | 90571                    | CUSTOMER        |
|   |        |                                 |            |                          | GENERAL MARKET  |
|   |        |                                 |            |                          | SHEET NUMBER    |
|   |        |                                 |            |                          | 1 OF 4          |

|       |       |       |       |        |                         |                         |                |
|-------|-------|-------|-------|--------|-------------------------|-------------------------|----------------|
| 78.74 | 86.34 | 90.52 | 96.62 | 100.74 | 90571-1641              |                         | 64             |
| 60.96 | 68.56 | 72.74 | 78.84 | 82.96  | -1501                   |                         | 50             |
| 48.26 | 55.86 | 60.04 | 66.14 | 70.26  | -1401                   |                         | 40             |
| 40.64 | 48.24 | 52.42 | 58.52 | 62.64  | -1341                   |                         | 34             |
| 35.56 | 43.16 | 47.34 | 53.44 | 57.56  | -1301                   |                         | 30             |
| 30.48 | 38.08 | 42.26 | 48.36 | 52.48  | -1261                   | 95071-1263              | 26             |
| 22.86 | 30.46 | 34.64 | 40.74 | 44.86  | -1201                   |                         | 20             |
| 17.78 | 25.38 | 29.56 | 35.66 | 39.78  | -1161                   |                         | 16             |
| 15.24 | 22.84 | 27.02 | 33.12 | 37.24  | -1141                   |                         | 14             |
| 10.16 | 17.76 | 21.94 | 28.04 | 32.16  | 90571-1101              |                         | 10             |
| A     | B     | C     | D     | E      | ENG. NO.<br>GS1 PLATING | ENG. NO.<br>GS2 PLATING | NO. OF<br>CKTS |

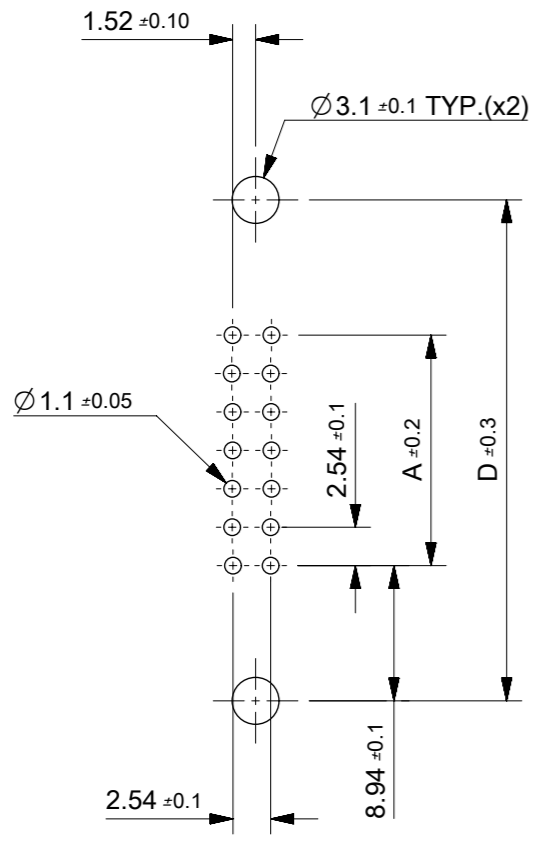

RECOMMENDED P.C.B. HOLE PATTERN

**NOTES:**

- MATERIAL: GLASS FILLED POLYESTER (UL 94 V0), COLOUR-BLACK.  
PINS: BRASS SIZE 0.635.  
LEVER: GLASS FILLED POLYESTER (UL 94 V0), COLOUR-BLACK.
- PLATING OPTIONS.  
90571-1\*\*1, 1µm MIN. NICKEL UNDERPLATE. CONTACT AREA GS1 PLATING 0.1µ MIN. GOLD. SOLDER AREA 3µm MIN.TIN.  
  
90571-1\*\*3, 1µm MIN. NICKEL UNDERPLATE. CONTACT AREA GS3 PLATING 0.25µ MIN. GOLD. SOLDER AREA 3µm MIN.TIN.
- RECOMMENDED PCB THICKNESS 1.6mm

|   |  |         |  |                                 |  |         |  |                          |  |   |  |
|---|--|---------|--|---------------------------------|--|---------|--|--------------------------|--|---|--|
| THIS DRAWING CONTAINS INFORMATION THAT IS PROPRIETARY TO MOLEX ELECTRONIC TECHNOLOGIES, LLC AND SHOULD NOT BE USED WITHOUT WRITTEN PERMISSION |  |         |  |                                 |  |         |  |                          |  |   |  |
| DIMENSION UNITS   |  | SCALE   |  | CURRENT REV DESC: CAD MIGRATION |  |         |  | <b>molex</b>             |  | QIK FLECS HEADER WITH<br>DIN EJECT LEVERS FOR<br>IMPROVED WIPE FEMALE |  |
| mm  |  | 2:1     |  |                                 |  |         |  |                          |  |   |  |
| GENERAL TOLERANCES (UNLESS SPECIFIED)   |  |         |  |                                 |  |         |  |                          |  |   |  |
| ANGULAR TOL   |  | ± 0.5 ° |  | EC NO: 605552                   |  |         |  | DOCUMENT NUMBER          |  | DOC TYPE   DOC PART   REVISION  |  |
| 4 PLACES  |  | ±       |  | DRWN: EEGBEDIRE 2018/12/12      |  |         |  | SDA-90571                |  | PSD   001   H1  |  |
| 3 PLACES  |  | ±       |  | CHK'D: TTOURISH 2019/04/15      |  |         |  | PRODUCT CUSTOMER DRAWING |  |   |  |
| 2 PLACES  |  | ± 0.15  |  | APPR: DMAHER 2019/04/15         |  |         |  | INITIAL REVISION:        |  |   |  |
| 1 PLACE   |  | ± 0.2   |  | DRWN: SM 03/08/1990             |  |         |  | MATERIAL NUMBER          |  | CUSTOMER  |  |
| 0 PLACES  |  | ±       |  | APPR: EFOLAN 08/25/2010         |  |         |  | SERIES                   |  | SHEET NUMBER  |  |
| DRAFT WHERE APPLICABLE<br>MUST REMAIN<br>WITHIN DIMENSIONS  |  |         |  | THIRD ANGLE PROJECTION          |  | DRAWING |  | SERIES                   |  | MATERIAL NUMBER   |  |
|   |  |         |  | A3-SIZE                         |  | 90571   |  | SEE CHART                |  | GENERAL MARKET  |  |

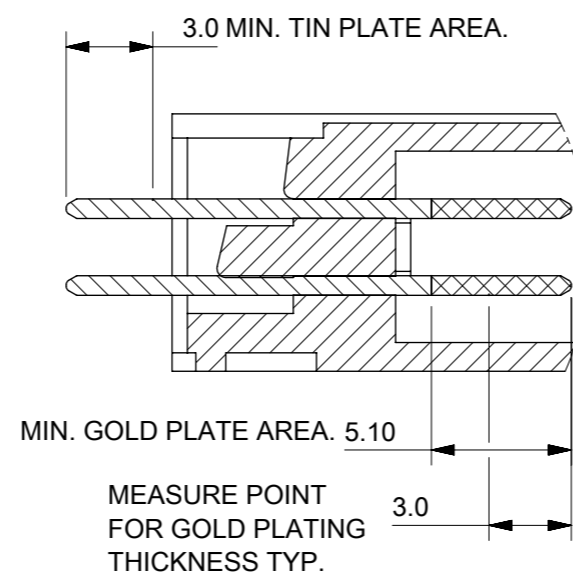
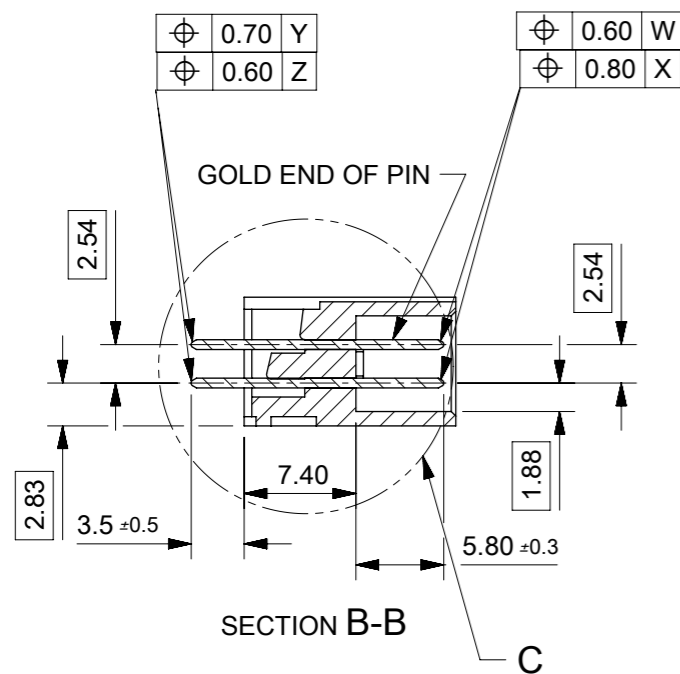
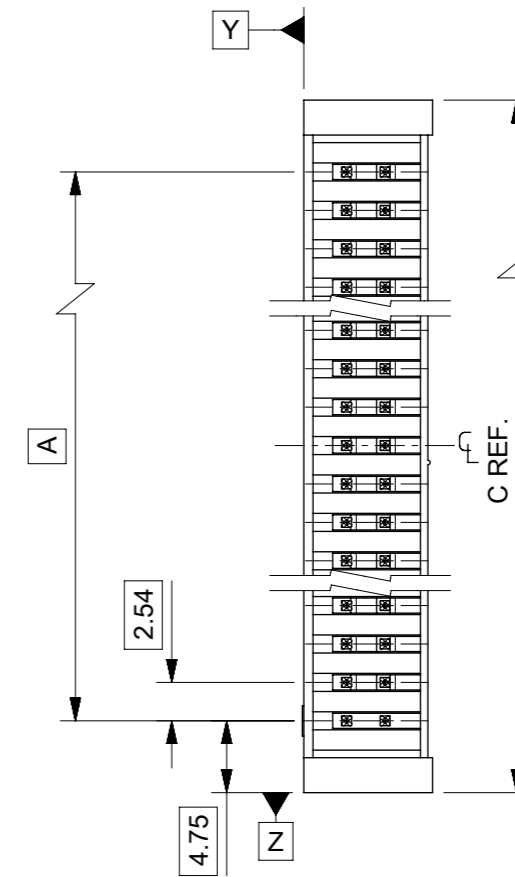
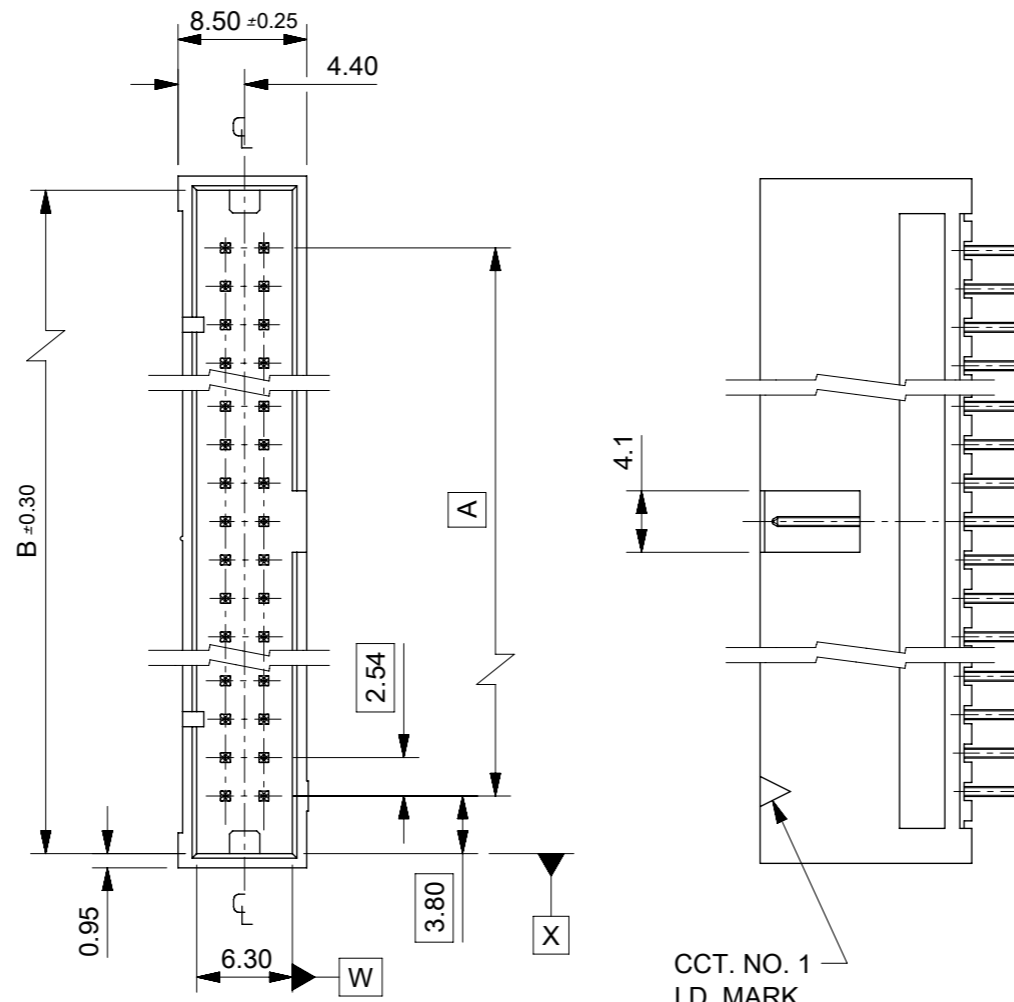
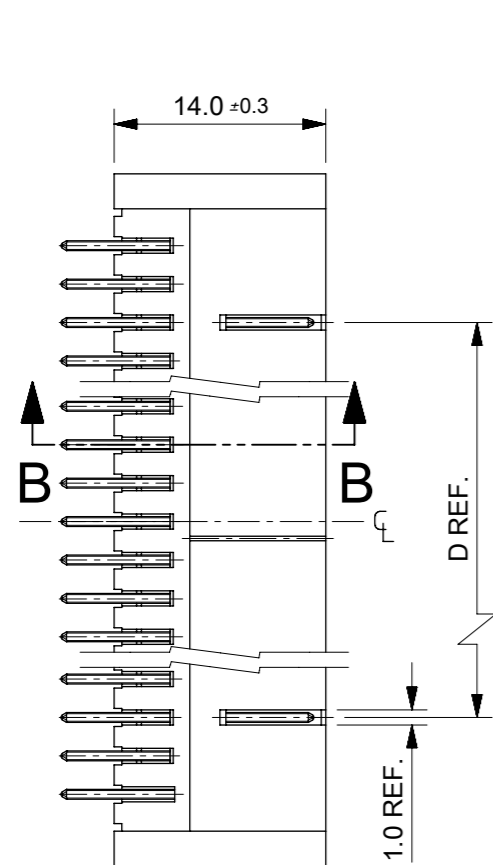

DETAIL C  
SCALE 4:1  
DIMENSIONS FOR SELECTIVE  
PLATING'S

NOTES:

1. FOR MATERIAL SPECIFICATION SEE NOTE 1. ON SHEET 4.
2. FOR RECOMMENDED P.C.B. HOLE PATTERN, PART NO'S AND UNSTATED DIMENSIONS SEE SHEET 4.
3. PRODUCT SPEC. NO.: PS-99020-0015

|   |        |  |            |                 |  |  |  |  |  |                |          |              |
|---|--------|--|------------|-----------------|--|--|--|--|--|----------------|----------|--------------|
| THIS DRAWING CONTAINS INFORMATION THAT IS PROPRIETARY TO MOLEX ELECTRONIC TECHNOLOGIES, LLC AND SHOULD NOT BE USED WITHOUT WRITTEN PERMISSION |        |  |            |                 |  |  |  |  |  |                |          |              |
| DIMENSION UNITS   | SCALE  | CURRENT REV DESC: CAD MIGRATION              |            |                 |  |  |  |  |  |                |          |              |
| mm  | 2:1    |  |            |                 |  |  |  |  |  |                |          |              |
| GENERAL TOLERANCES (UNLESS SPECIFIED)   |        |  |            |                 |  |  |  |  |  |                |          |              |
| ANGULAR TOL   | ± 0.5° | QUICK FLECTS HEADER FOR IMPROVED WIPE FEMALE |            |                 |  |  |  |  |  |                |          |              |
| 4 PLACES  | ±      | PRODUCT CUSTOMER DRAWING                     |            |                 |  |  |  |  |  |                |          |              |
| 3 PLACES  | ±      | EC NO: 605552                                | 2018/12/12 | DOCUMENT NUMBER |  |  |  |  |  | DOC TYPE       | DOC PART | REVISION     |
| 2 PLACES  | ± 0.15 | DRWN: EEGBEDIRE                              | 2019/04/15 | SDA-90571       |  |  |  |  |  | PSD            | 001      | H1           |
| 1 PLACE   | ± 0.2  | CHK'D: TTOURISH                              | 2019/04/15 | MATERIAL NUMBER |  |  |  |  |  | CUSTOMER       |          | SHEET NUMBER |
| 0 PLACES  | ±      | APPR: DMAHER                                 | 2019/04/15 | SEE SHEET 4     |  |  |  |  |  | GENERAL MARKET |          | 3 OF 4       |
| DRAFT WHERE APPLICABLE MUST REMAIN WITHIN DIMENSIONS  |        | INITIAL REVISION:                            | 03/08/1990 | SERIES          |  |  |  |  |  | A3-SIZE        |          | 90571        |
| THIRD ANGLE PROJECTION  |        | DRWING                                       | 08/25/2010 | MATERIAL NUMBER |  |  |  |  |  | CUSTOMER       |          | SHEET NUMBER |
|   |        | 03/08/1990                                   | 08/25/2010 | SEE SHEET 4     |  |  |  |  |  | GENERAL MARKET |          | 3 OF 4       |

|       |       |       |    |                         |                         |                |
|-------|-------|-------|----|-------------------------|-------------------------|----------------|
| 22.86 | 30.46 | 32.36 | -- | 90571-2201              | 90571-2203              | 20             |
| 10.16 | 17.76 | 19.66 | -- | 90571-2101              |                         | 10             |
| A     | B     | C     | D  | ENG. NO.<br>GS1 PLATING | ENG. NO.<br>GS2 PLATING | NO. OF<br>CKTS |

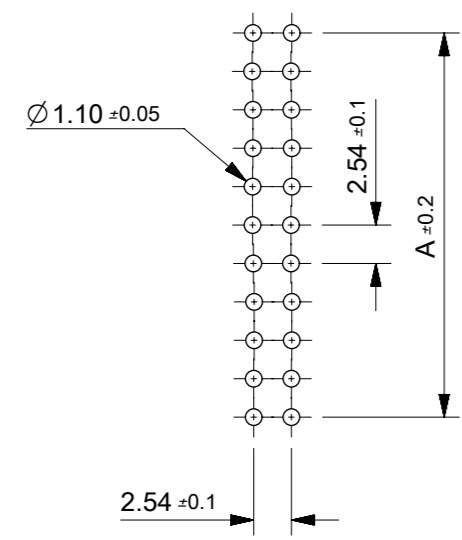

RECOMMENDED P.C.B. HOLE PATTERN.

NOTES:

- MATERIAL: GLASS FILLED POLYESTER (UL 94 V0), COLOUR-BLACK. PINS: BRASS SIZE 0.635.
- PLATING OPTIONS.  
 90571-2\*\*1, 1 $\mu$ m MIN. NICKEL UNDERPLATE. CONTACT AREA GS1 PLATING 0.1 $\mu$ m MIN. GOLD. SOLDER AREA 3 $\mu$ m MIN. TIN  
 90571-2\*\*3, 1 $\mu$ m MIN. NICKEL UNDERPLATE. CONTACT AREA GS3 PLATING 0.25 $\mu$ m MIN. GOLD. SOLDER AREA 3 $\mu$ m MIN. TIN.
- RECOMMENDED PCB THICKNESS 1.6mm

|   |         |                                 |         |            |                 |   |  |              |          |          |
|---|---------|---------------------------------|---------|------------|-----------------|---|--|--------------|----------|----------|
| THIS DRAWING CONTAINS INFORMATION THAT IS PROPRIETARY TO MOLEX ELECTRONIC TECHNOLOGIES, LLC AND SHOULD NOT BE USED WITHOUT WRITTEN PERMISSION |         |                                 |         |            |                 |   |  |              |          |          |
| DIMENSION UNITS   | SCALE   | CURRENT REV DESC: CAD MIGRATION |         |            |                 | <b>molex</b>                              |  |              |          |          |
| mm  | 2:1     |                                 |         |            |                 |   |  |              |          |          |
| GENERAL TOLERANCES (UNLESS SPECIFIED)   |         | EC NO: 605552                   |         |            |                 | QIK FLECS HEADER FOR IMPROVED WIPE FEMALE |  |              |          |          |
| ANGULAR TOL   | ± 0.5 ° | DRWN: EEGBEDIRE                 |         | 2018/12/12 |                 |   |  |              |          |          |
| 4 PLACES  | ±       | CHK'D: TTOURISH                 |         | 2019/04/15 |                 |   |  |              |          |          |
| 3 PLACES  | ±       | APPR: DMAHER                    |         | 2019/04/15 |                 | PRODUCT CUSTOMER DRAWING                  |  |              |          |          |
| 2 PLACES  | ± 0.15  | INITIAL REVISION:               |         |            |                 | DOCUMENT NUMBER                           |  | DOC TYPE     | DOC PART | REVISION |
| 1 PLACE   | ± 0.2   | DRWN: SM                        |         | 03/08/1990 |                 | SDA-90571                                 |  | PSD          | 001      | H1       |
| 0 PLACES  | ±       | APPR: EFOLAN                    |         | 08/25/2010 |                 |   |  |              |          |          |
| DRAFT WHERE APPLICABLE MUST REMAIN WITHIN DIMENSIONS  |         | THIRD ANGLE PROJECTION          | DRAWING | SERIES     | MATERIAL NUMBER | CUSTOMER                                  |  | SHEET NUMBER |          |          |
|   |         |                                 | A3-SIZE | 90571      | SEE CHART       | GENERAL MARKET                            |  | 4 OF 4       |          |          |