

REV.	DESCRIPTION	DATE	APPROVED
B	Engineering Update w/o Changes	02/24/04	M. C.
C	Removed Part From Part Offering List	09/29/15	J. C.
D	Added Notes 3, 4, 5 & Color Options Sheet #2	05/16/16	J. C.

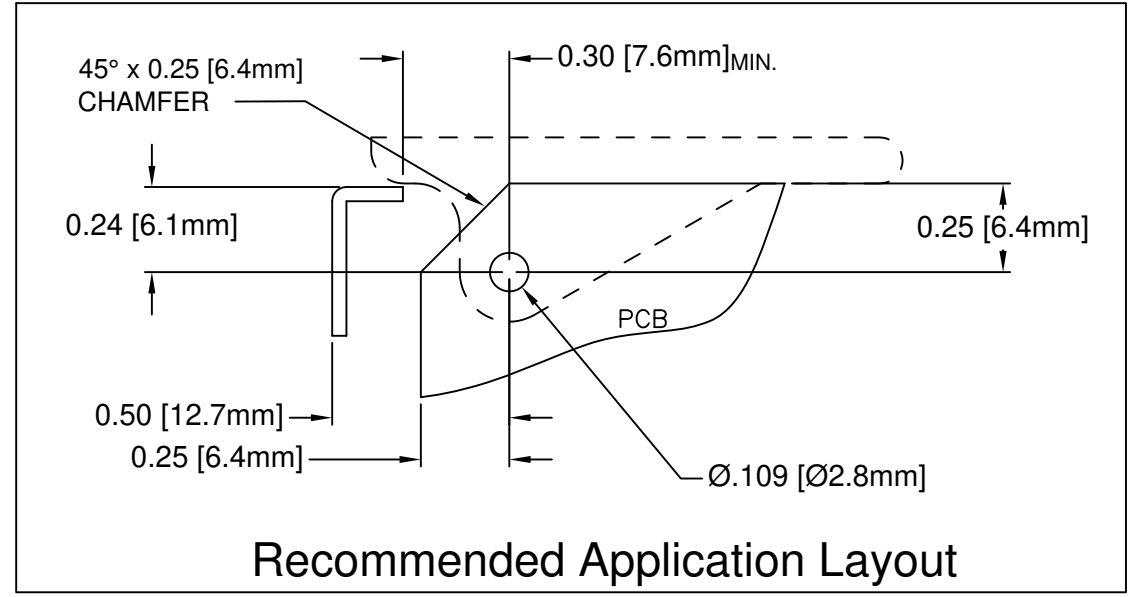
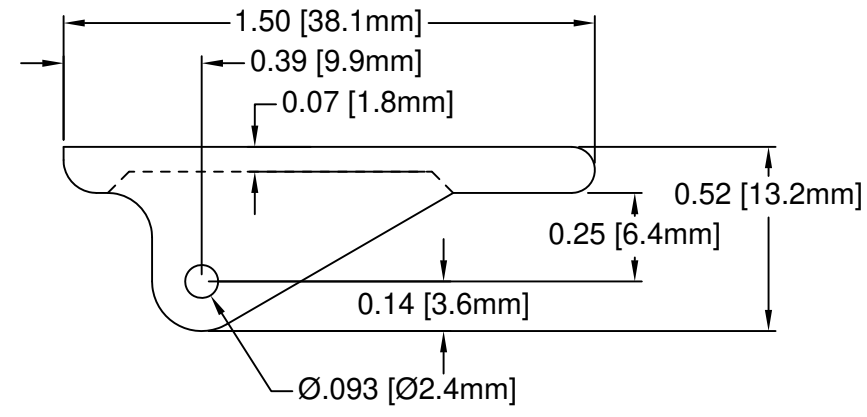
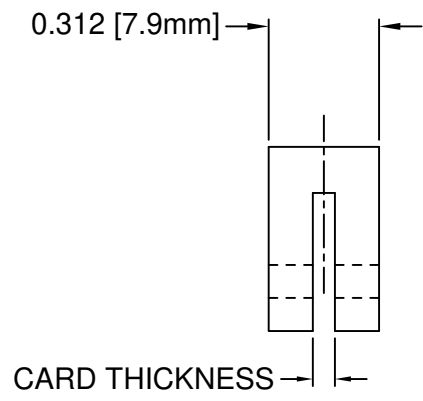

### Recommended Application Layout

PART NO.	COLOR	ROLL PIN	CARD THICK.
CP-56 WE	WHITE	RP-312	1/16"(1.6mm)
CP-56 XX	SEE S.#2	RP-312	
CP-59 WE	WHITE	RP-312	3/32"(2.4mm)
CP-59 XX	SEE S.#2	RP-312	

- 4. PRE-ASSEMBLED ROLL PINS AVAILABLE UPON REQUEST.
- 3. ROLL PINS INCLUDED. PACKAGED SEPARATELY.
- 2. MATERIAL: NYLON 6/6, 94V-2, WHITE.
- 1. GENERAL SPECIFICATIONS: BIVAR MOLDED COMPONENT SPECIFICATION BV00-E101.

STANDARD TOLERANCE (UNLESS OTHERWISE SPECIFIED)		<b>BIVAR</b> <sup>®</sup> 4 THOMAS, IRVINE, CA. 92618 TEL: (949) 951-8808 FAX: (949) 951-3974	
DECIMALS	ANGULAR		
.X ± .1	X° ± 1°		TITLE: CIRCUIT BOARD CARD EJECTOR
.XX ± .01			PART NO: CP-5XX
.XXX ± .005		DESIGNED: <b>D. Green</b>	DATE: 10/17/02
		CHECKED: <b>M. Chen</b>	DATE: 10/17/02
		CAGE CODE : 32559	SHEET # 1 OF 2
CAD GENERATED DOCUMENT. DO NOT MEASURE DRAWING.			

**OTHER AVAILABLE COLORS**

\* SEE TABLE FOR ORDERING INFORMATION



REV.	DESCRIPTION	DATE	APPROVED
	SEE SHEET #1		

**CP - 5** \_

CP SERIES
CP-56
CP-59

ORDER CODE	COLOR
AA	AQUA
BK	BLACK
BE	BLUE
BN	BROWN
FG	FOREST GREEN
GY	GRAY
GN	GREEN
LE	LIME
OE	ORANGE
PK	PINK
RD	RED
VT	VIOLET
YW	YELLOW

5. PARTS ARE DYED TO COLOR UPON REQUEST.

STANDARD TOLERANCE ( UNLESS OTHERWISE SPECIFIED ) DECIMALS                      ANGULAR		 4 THOMAS, IRVINE, CA. 92618 TEL.: (949) 951-8808    FAX: (949) 951-3974	
			
DESIGNED: <b>D. Green</b>	DATE: <b>10/17/02</b>	<b>TITLE:</b> CIRCUIT BOARD CARD EJECTOR	
CHECKED: <b>M. Chen</b>	DATE: <b>10/17/02</b>	<b>PART NO:</b> CP-5XX	REVISION: D
		<b>CAGE CODE :</b> 32559	<b>SHEET # 2 OF 2</b>
CAD GENERATED DOCUMENT. DO NOT MEASURE DRAWING.			