

SiLinkPS-EVB USER'S GUIDE

1. Introduction

The SiLinkPS-EVB is a system power supply board that provides all the necessary supply voltages for a variety of Skyworks Solutions' ProSLIC and silicon DAA evaluation boards. When used with an appropriate ac/dc wall adapter, the SiLinkPS-EVB can provide up to 25 W of total output power. Table 1 lists some typical voltages and currents at the power supply outputs.

Table 1. Power Supply Specifications

Input/Output	Voltage	Current	Power
V_{IN}	9–15 V	2.5 A	22–37 W
VBRNG	–96 V	100 mA	9.6 W
VBHI	–52 V or –78 V	100 mA	5.2 W or 7.8 W
VBLO	–26 V	200 mA	5.2 W
V_{DD}	3.3 V/5 V	1 A	3.3 W/5 W

Any combination of outputs is possible as long as the simultaneous total power from all outputs does not exceed the maximum rated 25 W and can be sufficiently supported by the input power from the V_{IN} .

The SiLinkPS-EVB is designed with the same footprint as all ProSLIC evaluation board daughter cards

allowing it to be used in conjunction with multiple ProSLIC daughter cards to create a modular evaluation platform.

The SiLinkPS-EVB circuit is based on two power supply controllers from Linear Technology that provide high efficiency and low bill-of-materials cost. Both circuits can be synchronized to the same switching frequency to reduce power supply switching noise. The outputs can be configured to support both internal and external ringing architectures by setting the provided jumpers to set the desired output voltages. Further modifications are possible to realize specific output voltage and current requirements provided the total output power does not exceed the rated maximum. Schematic capture and layout gerber files are available for integration into specific applications. Figure 1 illustrates a simplified block diagram of the SiLinkPS-EVB supply board.

2. Operating Instructions

The SiLinkPS-EVB board should always be connected to the ProSLIC evaluation board platform prior to turning on the power supply. Plugging any ProSLIC board into a live high-voltage supply can permanently damage the ProSLIC ICs. The user should exercise caution when touching any part of the SiLinkPS-EVB because dangerous high voltages are present and can cause injury.

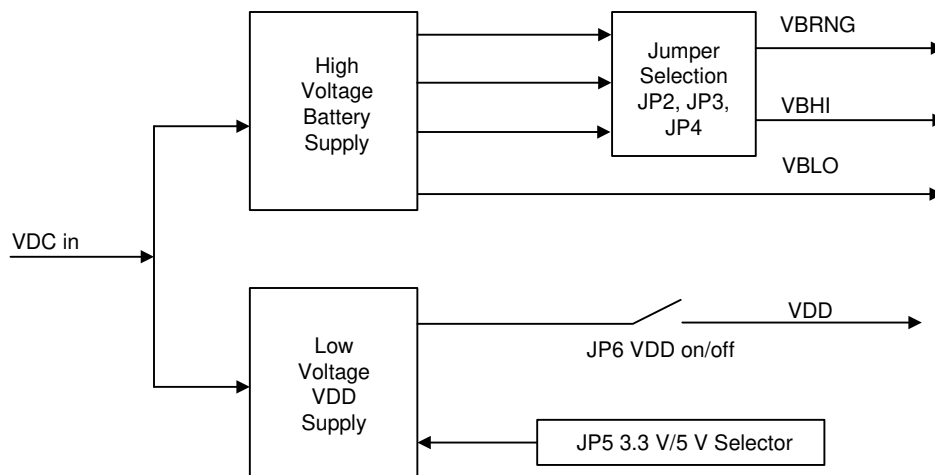

Figure 1. SiLinkPS-EVB Power Supply Simplified Block Diagram

2.1. High-Voltage Battery Supply

The schematic for this power circuit is illustrated in Figure 3 on page 4. The LTC3704 dc-dc controller IC is used to drive an external MOSFET and a multi-tap transformer to create four equal high-voltage negative outputs, VNEG (See Table 2), from the dc input supply. Only one output is regulated via close-loop feedback. The other three outputs are cross-regulated to the first output via the transformer ratio. The LTC3704's negative feedback input eliminates inverting circuitry when creating negative outputs from a positive input. The six-winding 1:1 ratio transformer is configured in a manner that minimizes the need for multiple high-voltage output filter capacitors.

2.2. VNEG Voltage Adjustment

The transformer, T1, has four secondary windings, each producing an equal negative voltage, VNEG. These four windings are connected in series through the diode rectifying circuits to produce four negative voltage potentials with voltage levels equal to multiples from 1 to 4 of the VNEG magnitude. Any adjustment made to the VNEG has a direct effect on the voltage levels on all negative outputs.

Resistor R23 can be modified to realize custom output voltages as defined in the following equation.

$$VNEG = (1.23 \times R23/R22) + 1.23$$

The SiLinkPS-EVB is shipped with $R23 = 33.2 \text{ k}$ and $R22 = 1.65 \text{ k}$ for VNEG equal to 26 V.

The VBLO is normally used for off-hook state and its voltage level can be programmed by the setting on the

JP7 jumper. The voltage on the VBHI and VBRNG outputs can be programmed by moving the jumper settings on JP2, JP3, and JP4. Table 2 provides several popular configurations and the required jumper settings.

2.3. Frequency Adjustment

The LTC3704 can be configured to run at switching frequencies from 50 kHz to 1 MHz allowing flexibility to choose the optimal efficiency/cost point for each specific application. Resistor R18 programs the switching frequency according to the characteristic curve shown in Figure 2.

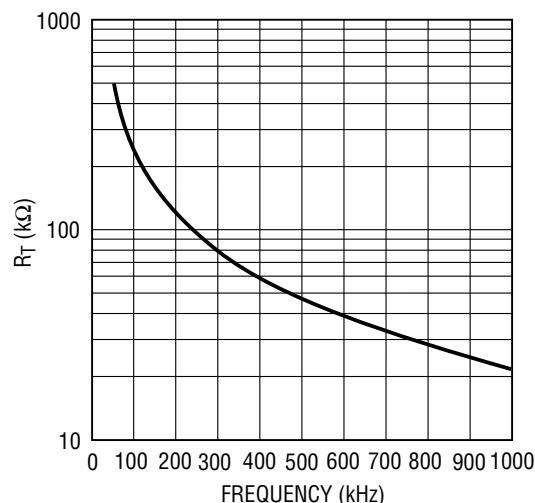

Figure 2. Timing Resistor R18 Value

Table 2. Popular Application Configurations and Jumper Settings

Dual ProSLIC Part Number	PK-PK Ringing Amplitude	VBRNG	VBHI	VBLO	JP2	JP3	JP4	JP7
Si3211/Si3212 Si3220/Si3232	75 V	—	-78 V 3xVNEG	-26 V VNEG	2-3	2-3	1-2	2-3
	90 V	-104 V 4xVNEG	—	-26 V VNEG	1-2	—	—	2-3
Si3225	N/A (external)	—	-52 V 2xVNEG	-26 V VNEG	2-3	—	2-3	2-3

2.4. Low Voltage V_{DD} Supply

The low-voltage supply provides a switchable 3.3 V or 5 V output with a 1 A maximum load current. The schematic for this power supply circuit is illustrated in Figure 4 on page 5. The LT1375 IC integrated 1.5 A bipolar switching transistor and current-sensing circuitry eliminate external power transistors and sense resistors and provide a high-efficiency V_{DD} supply in a small footprint. The switching frequency is internally fixed at 500 kHz and can be synchronized to higher frequencies up to 1 MHz when a higher frequency signal (above 550 kHz) is provided on the SYNC pin. Table 3 provides the jumper settings for selecting a 3.3 V or 5 V output as well as for disconnecting the V_{DD} supply altogether.

Table 3. V_{DD} Supply Jumper Settings

Function	JP5	JP6	Comments
V_{DD} output enable	—	1–2	V_{DD} connected
	—	2–3	V_{DD} disconnected
3.3 V/5 V configuration	1–2	—	5 V selected
	2–3	—	3.3 V selected

2.5. Frequency Synchronization

The LTC3704 is wired as a clock master device to provide its switching frequency to the SYNC pin on the LT1375 IC. To synchronize the frequency between the two power circuits, R18 needs to be adjusted to set the LTC3704 switching frequency at or above 550 kHz. The LT1375 IC operates at its internal fixed 500 kHz and is only synchronized with the LTC3704 frequency when it senses the frequency on the SYNC pin going above 550 kHz. The SiLinkPS-EVB power circuits are designed to operate safely with switching frequency on the LTC3704 ranging from 200 kHz to 1 MHz.

2.6. Initialization Steps

1. Configure all jumpers according to the application requirements.
2. (Optional) Plug in the input power source and measure all outputs to verify correct settings.
3. Unplug input power source.
4. Assemble all ProSLIC daughter cards.
5. Plug in the input power source.

2.7. Cost-Optimized Design

The negative high-voltage circuit can be reduced for cost optimization. The four equal VNEG outputs in series arrangement provide some discrete voltage adjustments to the outputs but require additional rectifying diode circuits and increase cost. Figure 6 on page 8 illustrates a lost-optimized design with two negative outputs. The first secondary winding produces a negative voltage according to the VNEG equation described in the previous section to produce the VBLO voltage. The other three secondary windings are connected in series to produce a negative voltage with an amplitude of $3 \times V_{NEG}$. This output is connected in series with the VBLO output to generate VBHI output with a voltage level of $4 \times V_{NEG}$.

The use of the simplified secondary rectifying circuit, smaller transformer, and switching MOSFET lower the component costs and also reduce the maximum output power of the negative high-voltage circuit to 13 W.

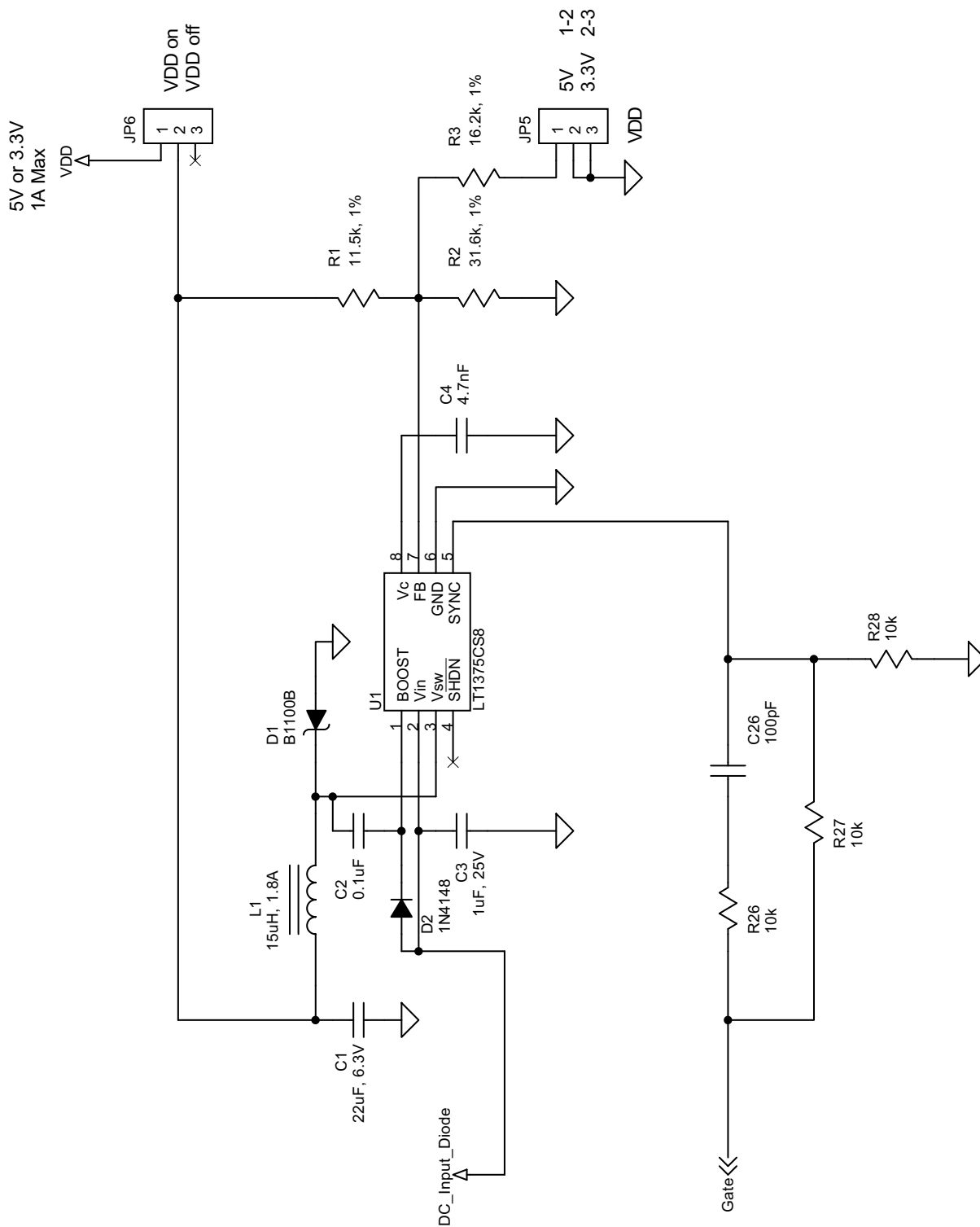

Figure 4. Low-Voltage V_{DD} Supply

3. Si Link PS–EVB Bill of Materials

Reference	Description	Part Number	Manufacturer
C1	22uF, 6.3V		
C2	0.1uF, 10V		
C3,C8,C11,C15	1uF, 25V		
C4	4.7nF, 10V		
C5,C9,C12,C17	10uF, 25V	TMK432BJ106KM	Taiyo Yuden
C7,C10,C13	1uF, 100V	18121C105KAT9A	United Chemi-con
C22,C14	.001uF, 25V	08055C102KAT	AVX
C18	0.1uF, 35V	08053C104KAT	AVX
C16, C19	4.7uF, 50V	C5750X7R1H475K	TDK
C20,C26	100pF, 25V	08055A101KAT	AVX
C21	4.7uF, 10V	LMK316BJ475	Taiyo Yuden
C23	.001uF, 25V		
C24	330uF, 35V		
D2	1N4148		Diodes, Inc.
D3	ES3A/B	ES3A/B	Diodes, Inc.
D1,D5,D8,D11,D12	B1100B	B160B	Diodes, Inc.
D9,D10	47V Zener		
JP1	CONN HEADER 2x2/SM	TSM-102-02-T-DV	Samtec
JP2,JP3,JP4,JP5,JP6,JP7	HEADER 3X1	2303-6111TN	3M
JS1,JS3,JS4,JS5	CONN SOCKET 5x2	SSQ-1-05-24-F-D	Samtec
JS2	CONN SOCKET 2x2/SM	SSM-102-L-DV-TR	Samtec
J1	CONN PWR 2-P	ADC-002-1	Adam Tech
L1	15uH, 1.8A	UP1B-150	Coiltronics
L2	10uH	CTX32CT-100	Coiltronics
Q1	FZT953CT	FZT953CT	Zetex
Q2	IRL540NS	IRL540NS	Int. Rectifier
R1	11.5k Ω , 1%		
R2	31.6k Ω , 1%		
R3	16.2k Ω , 1%		
R4,R9,R11,R15,R26,R27,R28	10k Ω , 5%		
R6	10k Ω , 5%		
R7	100k Ω , 5%		
R8	4.7k Ω , 5%		
R13	13k Ω , 5%		
R21,R14	82k Ω , 5%		
R17	4.7 Ω , 5%		
R18	120k Ω , 5%		
R19	47 Ω , 5%		
R20	15m Ω , 5%	LRC1206-R015K	IRC
R22	1.65k Ω , 5%		
R23	33.2k Ω , 5%		
R25	0 Ω		
T1	VP5	VPH5-0155	Coiltronics
U1	LT1375CS8	LT1375CS8	LTC
U2	LTC3704EMS	LTC3704CMS	LTC

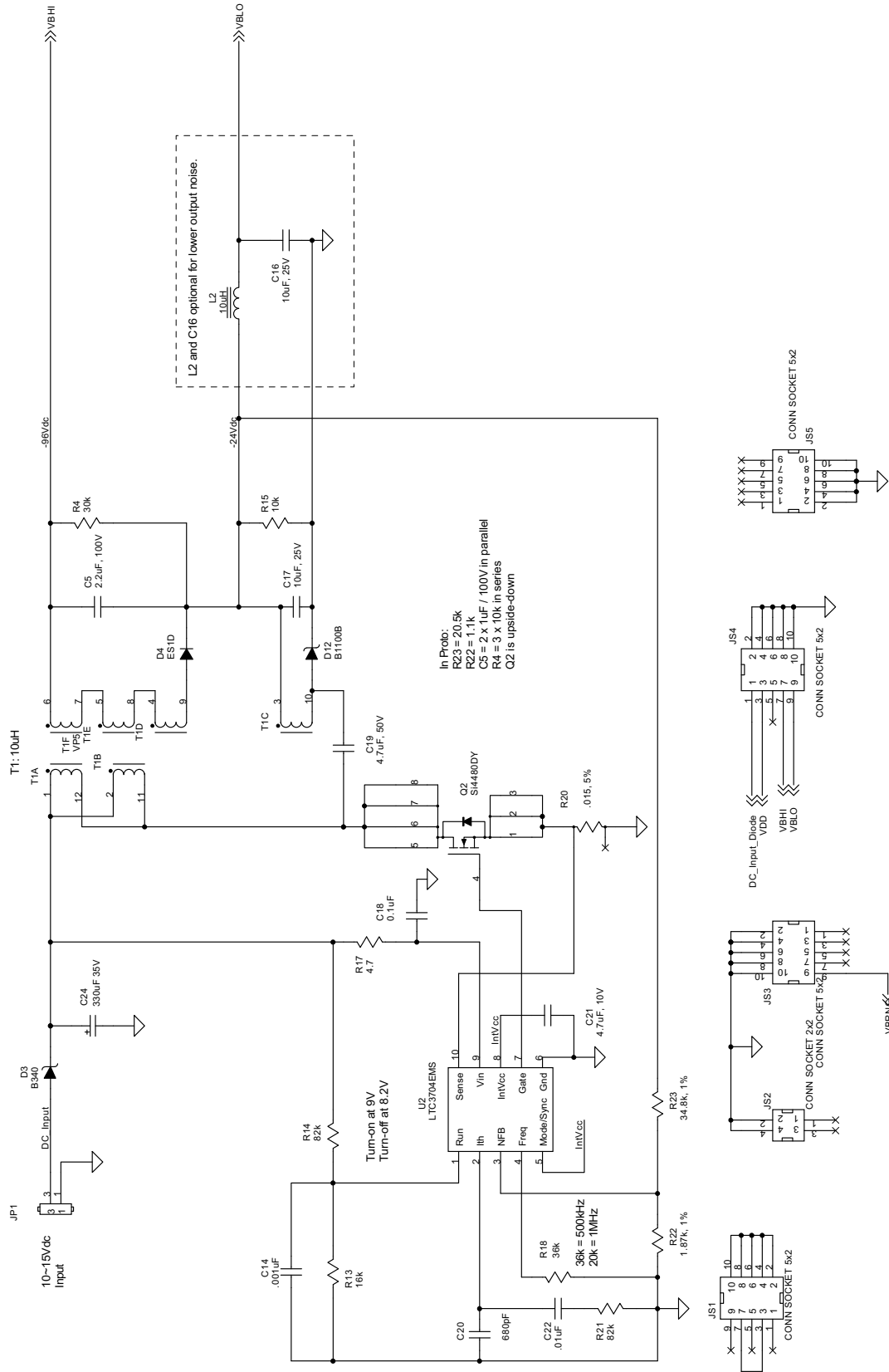

Figure 6. Cost-Optimized Dual Output Battery Supply

4. Cost-Optimized Dual Output Battery Supply Bill of Materials

Reference	Description	Part Number	Manufacturer
C18	0.1 μ F, 25 V, X7R	08053C104KAT	AVX
C5	2.2 μ F, 100 V, X7R	C5750X7R2A225M	TDK
C22, C14	1 nF, 25 V, X7R		
C16*, C17	10 μ F, 25 V, X5R	TMK432BJ106KM	Taiyo Yuden
C19	4.7 μ F, 50 V, X7R	UMK325F475KH	Taiyo Yuden
C20	100 pF, 50 V, NP0	08055A101KAT	AVX
C21	4.7 μ F, 10 V, X5R	LMK316BJ475	Taiyo Yuden
C24	330 μ F, 35 V	35CV330AX	Sanyo
D3	40 V, 3 A	B340	Diodes, Inc.
D4	200 V, 1 A	ES1D	Diodes, Inc.
D12	100 V, 1 A Schottky	B1100B	Diodes, Inc.
L2*	10 μ H, 300 mA	CTX32CT-470	Coiltronics
Q2	80 V	Si4480DY	Vishay
R4	30 k Ω , 5%, 0.25 W		
R13	16 k Ω , 5%, 0.1 W		
R21, R14	82 k Ω , 5%, 0.1 W		
R15	10 k Ω , 5%, 0.1 W		
R17	4.7 Ω , 5%, 0.1 W		
R18	36 k Ω , 5%, 0.1 W		
R20	15 m Ω , 5%, 0.25 W		
R22	1.87 k Ω , 1%, 0.1 W		
R23	34.8 k Ω , 1%, 0.1 W		
T1	10 μ H	SP36-0100-10	Transpower
U2	Switching Regulator	LTC3704EMS	LTC

Note: * Optional components used to reduce output noise if necessary.

DOCUMENT CHANGE LIST

Revision 0.1 to Revision 0.2

- New power supply schematics
 - Updated Figures 3, 4, and 5.
- Updated document to support two levels of VBATL voltage.

NOTES:



SKYWORKS®

**Connecting Everyone
and Everything,
All the Time**



Portfolio

www.skyworksinc.com

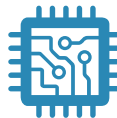

Quality

www.skyworksinc.com/quality



Support & Resources

www.skyworksinc.com/support

Copyright © 2021 Skyworks Solutions, Inc. All Rights Reserved.

Information in this document is provided in connection with Skyworks Solutions, Inc. ("Skyworks") products or services. These materials, including the information contained herein, are provided by Skyworks as a service to its customers and may be used for informational purposes only by the customer. Skyworks assumes no responsibility for errors or omissions in these materials or the information contained herein. Skyworks may change its documentation, products, services, specifications or product descriptions at any time, without notice. Skyworks makes no commitment to update the materials or information and shall have no responsibility whatsoever for conflicts, incompatibilities, or other difficulties arising from any future changes.

No license, whether express, implied, by estoppel or otherwise, is granted to any intellectual property rights by this document. Skyworks assumes no liability for any materials, products or information provided hereunder, including the sale, distribution, reproduction or use of Skyworks products, information or materials, except as may be provided in Skyworks' Terms and Conditions of Sale.

THE MATERIALS, PRODUCTS AND INFORMATION ARE PROVIDED "AS IS" WITHOUT WARRANTY OF ANY KIND, WHETHER EXPRESS, IMPLIED, STATUTORY, OR OTHERWISE, INCLUDING FITNESS FOR A PARTICULAR PURPOSE OR USE, MERCHANTABILITY, PERFORMANCE, QUALITY OR NON-INFRINGEMENT OF ANY INTELLECTUAL PROPERTY RIGHT; ALL SUCH WARRANTIES ARE HEREBY EXPRESSLY DISCLAIMED. SKYWOKS DOES NOT WARRANT THE ACCURACY OR COMPLETENESS OF THE INFORMATION, TEXT, GRAPHICS OR OTHER ITEMS CONTAINED WITHIN THESE MATERIALS. SKYWOKS SHALL NOT BE LIABLE FOR ANY DAMAGES, INCLUDING BUT NOT LIMITED TO ANY SPECIAL, INDIRECT, INCIDENTAL, STATUTORY, OR CONSEQUENTIAL DAMAGES, INCLUDING WITHOUT LIMITATION, LOST REVENUES OR LOST PROFITS THAT MAY RESULT FROM THE USE OF THE MATERIALS OR INFORMATION, WHETHER OR NOT THE RECIPIENT OF MATERIALS HAS BEEN ADVISED OF THE POSSIBILITY OF SUCH DAMAGE.

Skyworks products are not intended for use in medical, lifesaving or life-sustaining applications, or other equipment in which the failure of the Skyworks products could lead to personal injury, death, physical or environmental damage. Skyworks customers using or selling Skyworks products for use in such applications do so at their own risk and agree to fully indemnify Skyworks for any damages resulting from such improper use or sale.

Customers are responsible for their products and applications using Skyworks products, which may deviate from published specifications as a result of design defects, errors, or operation of products outside of published parameters or design specifications. Customers should include design and operating safeguards to minimize these and other risks. Skyworks assumes no liability for applications assistance, customer product design, or damage to any equipment resulting from the use of Skyworks products outside of Skyworks' published specifications or parameters.

Skyworks, the Skyworks symbol, Sky5®, SkyOne®, SkyBlue™, Skyworks Green™, Clockbuilder®, DSPLL®, ISOModem®, ProSLIC®, and SiPHY® are trademarks or registered trademarks of Skyworks Solutions, Inc. or its subsidiaries in the United States and other countries. Third-party brands and names are for identification purposes only and are the property of their respective owners. Additional information, including relevant terms and conditions, posted at www.skyworksinc.com, are incorporated by reference.

Skyworks Solutions, Inc. | Nasdaq: SWKS | sales@skyworksinc.com | www.skyworksinc.com

USA: 781-376-3000 | Asia: 886-2-2735 0399 | Europe: 33 (0)1 43548540 |