



FAN5331

High Efficiency Serial LED Driver and OLED Supply with 20V Integrated Switch

Features

- 1.6MHz Switching Frequency
- Low Noise
- Low $R_{DS(ON)}$: 0.5 Ω
- Adjustable Output Voltage
- 1A Peak Switch Current
- 1W Output Power Capability
- Low Shutdown Current: <1 μ A
- Cycle-by-Cycle Current Limit
- Over-Voltage Protection
- Fixed-Frequency PWM Operation
- Internal Compensation
- 5-lead SOT-23 Package

Applications

- Cell Phones
- PDAs
- Handheld Equipment
- Display Bias
- LED Bias

Description

The FAN5331 is a general purpose, fixed-frequency boost converter designed to operate at high switching frequencies in order to minimize switching noise measured at the battery terminal of hand-held communications equipment. Quiescent current in normal mode of operation as well as in shutdown mode is designed to be minimal in order to extend battery life. Normal mode of operation or shutdown mode can be selected by a logic level shutdown circuitry.

The low ON-resistance of the internal N-channel switch ensures high efficiency and low power dissipation. A cycle-by-cycle current limit circuit keeps the peak current of the switch below a typical value of 1A. The FAN5331 is available in a 5-lead SOT-23 package.

Typical Application

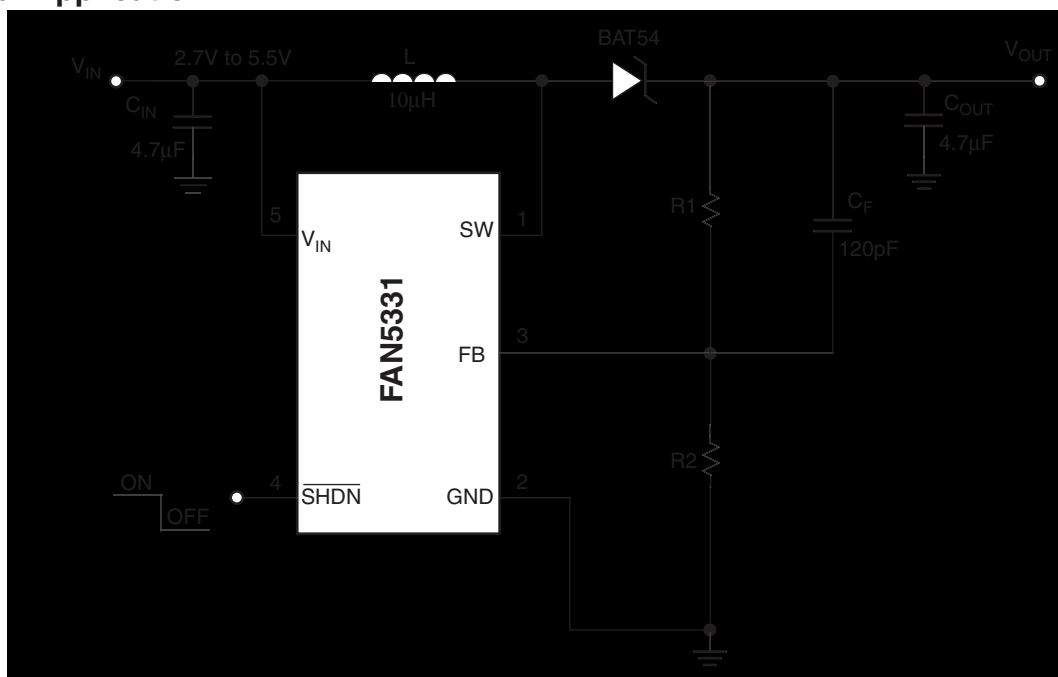

Figure 1. Typical Application Diagram

Pin Assignment

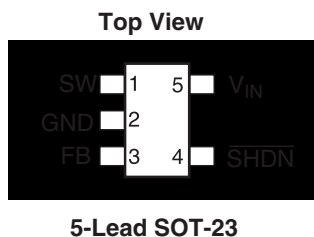

Figure 2. Pin Assignment

Pin Description

Pin No.	Pin Name	Pin Description
1	SW	Switching node.
2	GND	Analog and power ground.
3	FB	Feedback node that connects to an external voltage divider.
4	SHDN	Shutdown control pin. Logic HIGH enables, logic LOW disables the device.
5	V _{IN}	Input voltage.

Absolute Maximum Ratings (Note1)

Parameter	Min	Max	Unit
V _{IN} to GND		6.0	V
FB, SHDN to GND	-0.3	V _{IN} + 0.3	V
SW to GND	-0.3	23	V
Lead Soldering Temperature (10 seconds)		300	°C
Junction Temperature		150	°C
Storage Temperature	-55	150	°C
Thermal Resistance (θ _{JA})		265	°C/W
Electrostatic Discharge Protection (ESD) Level (Note 2)	HBM	2.5	kV
	CDM	1	

Recommended Operating Conditions

Parameter	Min	Typ	Max	Unit
Input Voltage	2.7		5.5	V
Output Voltage	V _{IN}		20	V
Operating Ambient Temperature	-40	25	85	°C
Output Capacitance (Note 3)	1.6			μF

Notes:

- Stresses above those listed under “Absolute Maximum Ratings” may cause permanent damage to the device. This is a stress rating only and functional operation of the device at these or any other conditions above those indicated in the operational section of this specification is not implied. Exposure to absolute maximum rating conditions for extended periods may affect device reliability. Absolute maximum ratings apply individually only, not in combination.
- Using EIA/JESD22A114B (Human Body Model) and EIA/JESD22C101-A (Charge Device Model).
- This load capacitance value is required for the loop stability. Tolerance, temperature variation, and voltage dependency of the capacitance must be considered. Typically a 4.7μF ceramic capacitor is required to achieve specified value at V_{OUT} = 15V.

Electrical Characteristics

Unless otherwise noted, $V_{IN} = 3.6V$, $T_A = -40^{\circ}C$ to $+85^{\circ}C$, Typical values are at $T_A = 25^{\circ}C$, Test Circuit, Figure 3.

Parameter	Conditions	Min.	Typ.	Max.	Units
Switch Current Limit	$V_{IN} = 3.2V$	0.7	1		A
Load Current Capability	$V_{OUT} = 15V, V_{IN} \geq 2.7V$	35			mA
	$V_{OUT} = 15V, V_{IN} \geq 3.2V$	50			mA
Switch On-resistance	$V_{IN} = 5V$		0.5		Ω
	$V_{IN} = 3.6V$		0.7		Ω
Quiescent Current	$V_{SHDN} = 3.6V$, No Switching		0.7		mA
	$V_{SHDN} = 3.6V$, Switching		1.6	3.0	mA
OFF Mode Current	$V_{SHDN} = 0V$		0.1	2	μA
Shutdown Threshold	Device ON	1.5			V
	Device OFF			0.5	V
Shutdown Pin Bias Current	$V_{SHDN} = 0V$ or $V_{SHDN} = 5.5V$		10		nA
Feedback Voltage	$I_{Load} = 0mA$	1.205	1.230	1.255	V
Feedback Pin Bias Current			10		nA
Feedback Voltage Line Regulation	$2.7V < V_{IN} < 5.5V, I_{LOAD} = 0mA$		0.6	1.2	%
Switching Frequency		1.15	1.6	1.85	MHz
Maximum Duty Cycle		87	93		%
Enable Delay	$V_{IN} = 2.7V, I_{OUT} = 35mA, V_{OUT} = 15V$		0.8	5	mS
Power on Delay	$V_{IN} = 2.7V, I_{OUT} = 35mA, V_{OUT} = 15V$		0.8	5	mS
Switch Leakage Current	No Switching, $V_{IN} = 5.5V$			1	μA

Test Circuit

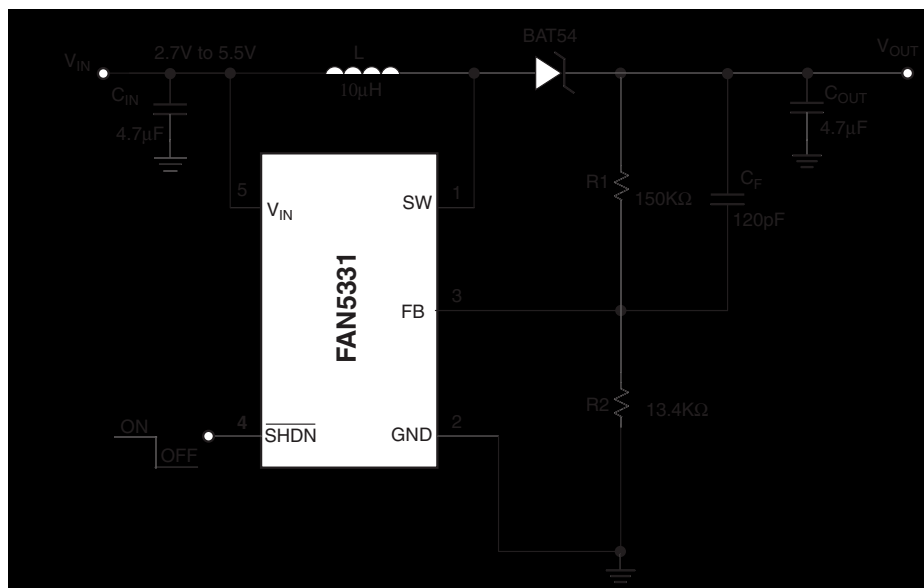
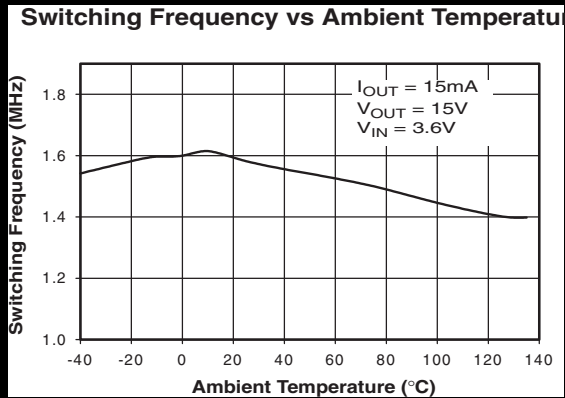
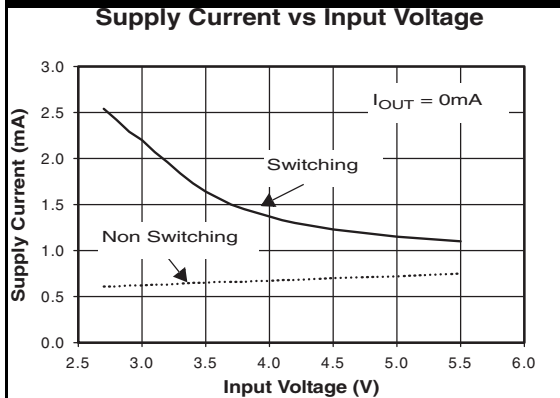
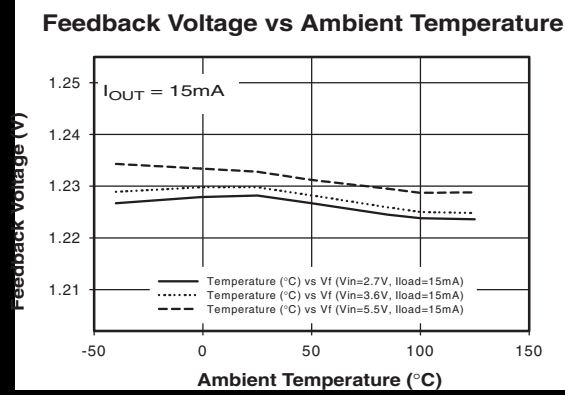
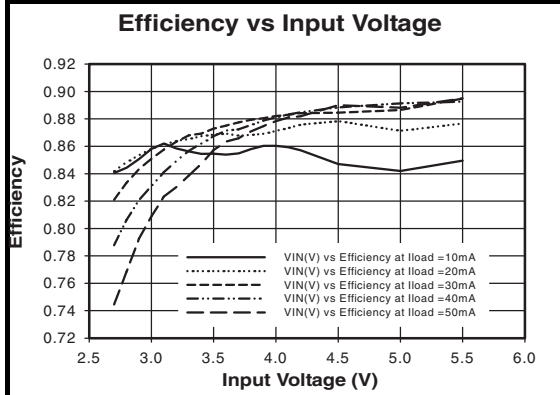
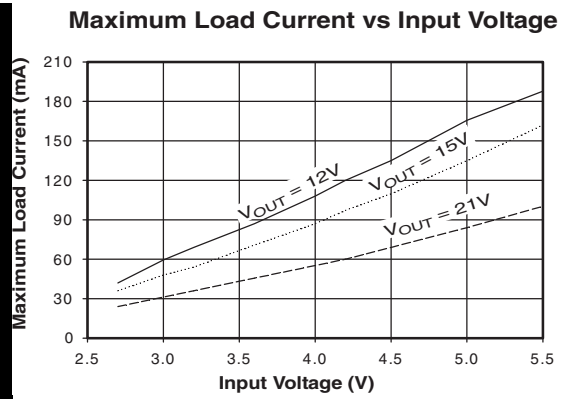
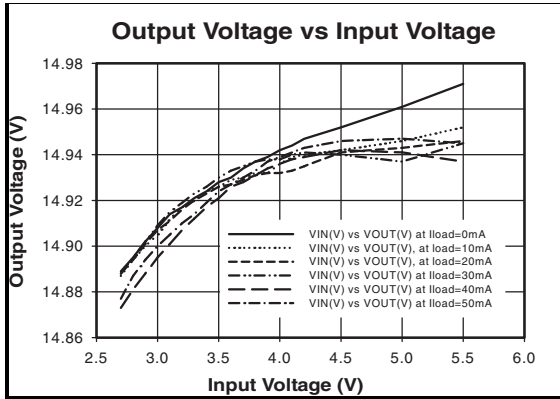

Figure 3. Test Circuit

Typical Performance Characteristics

$T_A = 25^\circ\text{C}$, Test Circuit Figure 3, unless otherwise noted.



Typical Performance Characteristics (Contd.)

$T_A = 25^\circ\text{C}$, Test Circuit Figure 3, unless otherwise noted.

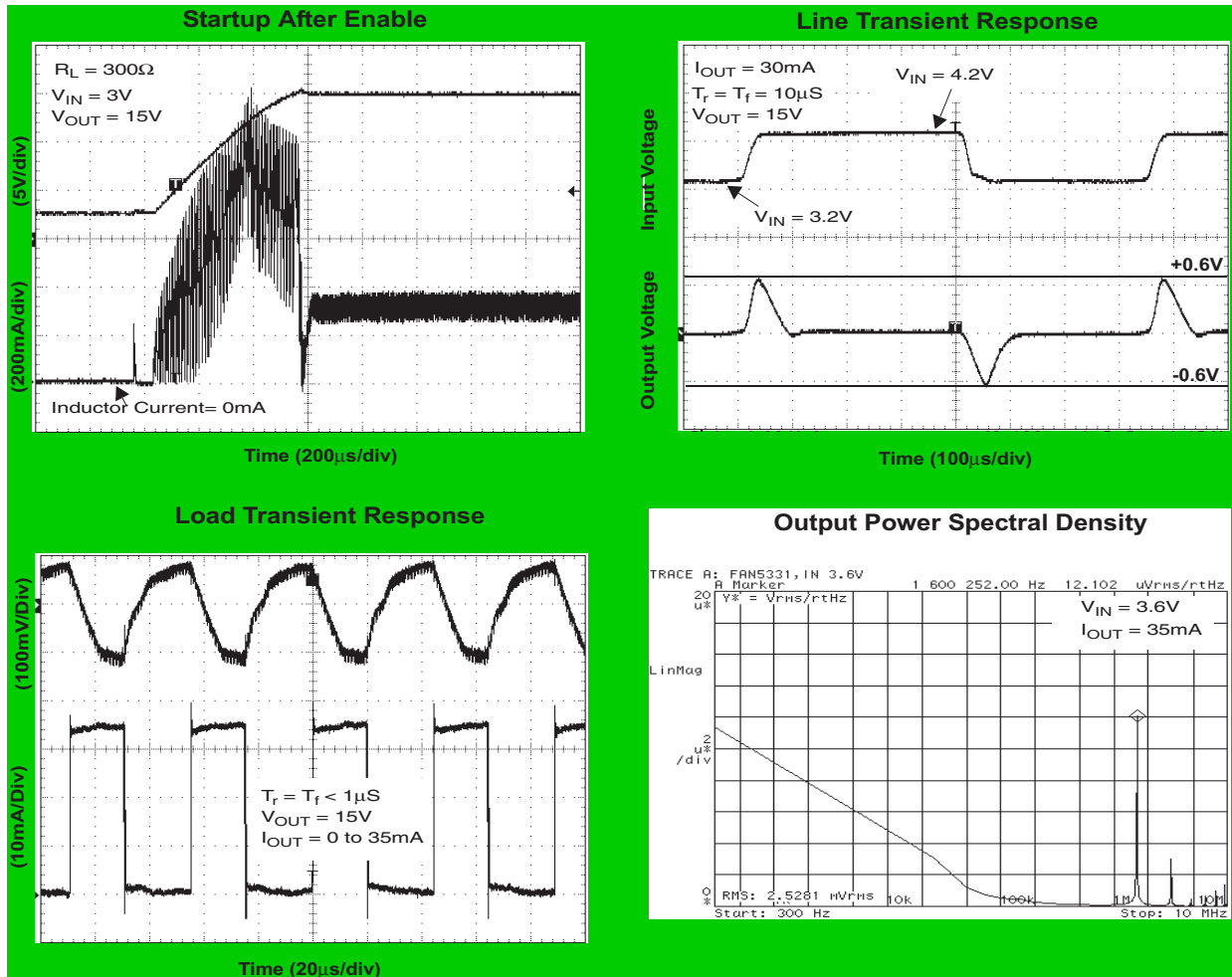

Block Diagram

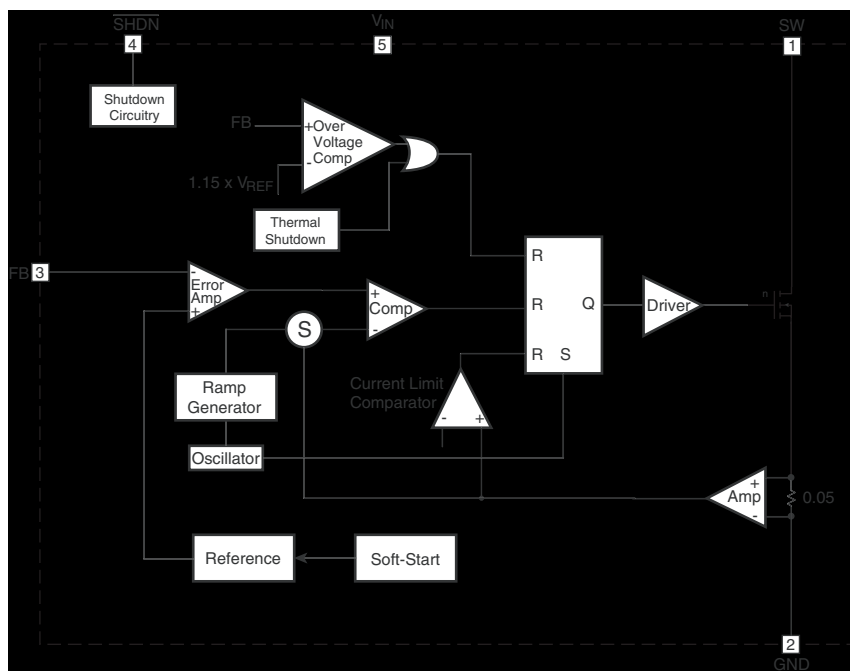

Figure 4. Block Diagram

Circuit Description

The FAN5331 is a pulse-width modulated (PWM) current-mode boost converter. The FAN5331 improves the performance of battery powered equipment by significantly minimizing the spectral distribution of noise at the input caused by the switching action of the regulator. In order to facilitate effective noise filtering, the switching frequency was chosen to be high, 1.6MHz. An internal soft start circuitry minimizes in-rush currents. The timing of the soft start circuit was chosen to reach 95% of the nominal output voltage within maximum 5mS following an enable command when $V_{IN} = 2.7V$, $V_{OUT} = 15V$, $I_{LOAD} = 35mA$ and $C_{OUT (EFFECTIVE)} = 3.2\mu F$.

The device architecture is that of a current mode controller with an internal sense resistor connected in series with the N-channel switch. The voltage at the feedback pin tracks the output voltage at the cathode of the external Schottky diode (shown in the test circuit). The error amplifier amplifies the difference between the feedback voltage and the internal bandgap reference. The amplified error voltage serves as a reference voltage to the PWM comparator. The inverting input of the PWM comparator consists of the sum of two components: the amplified control signal received from the 50mΩ current sense resistor and the ramp generator voltage derived from the oscillator. The oscillator sets the latch, and the latch turns on the FET switch. Under normal operating conditions, the PWM comparator resets the latch and turns off the FET, thus terminating the pulse. Since the comparator input contains information about the output voltage and the control loop is arranged to form a negative feedback loop, the value of the peak inductor current will be adjusted to maintain regulation.

Every time the latch is reset, the FET is turned off and the current flow through the switch is terminated. The latch can be

reset by other events as well. Over-current condition is monitored by the current limit comparator which resets the latch and turns off the switch instantaneously within each clock cycle.

Over-Voltage Protection

The voltage on the feedback pin is sensed by an OVP Comparator. When the feedback voltage is 15% higher than the nominal voltage, the OVP Comparator stops switching of the power transistor, thus preventing the output voltage from going higher.

Applications Information

Setting the Output Voltage

The internal reference is 1.23V (Typical). The output voltage is divided by a resistor divider, R1 and R2 to the FB pin. The output voltage is given by

$$V_{OUT} = V_{REF} \left(1 + \frac{R_1}{R_2} \right)$$

According to this equation, and assuming desired output voltage of 15V, good choices for the feedback resistors are, $R_1=150k\Omega$ and $R_2=13.4k\Omega$.

Inductor Selection

The inductor parameters directly related to device performances are saturation current and dc resistance. The FAN5331 operates with a typical inductor value of 10μH. The lower the dc resistance, the higher the efficiency. Usually a trade-off between inductor size, cost and overall efficiency is needed to make the optimum choice.

The inductor saturation current should be rated around 1A, which is the threshold of the internal current limit circuit. This limit is reached only during the start-up and with heavy load condition; when this event occurs the converter can shift over in discontinuous conduction mode due to the automatic turn-off of the switching transistor, resulting in higher ripple and reduced efficiency.

Some recommended inductors are suggested in the table below:

Inductor Value	Vendor	Part Number	Comment
10μH	Panasonic	ELL6GM100M	Lower Profile (1.6mm)
10μH	Murata	LQS66SN100M03L	Highest Efficiency
10μH	Coilcraft	DO1605T-103Mx	Small Size

Table 1: Recommended Inductors

Capacitors Selection

For best performance, low ESR input and output capacitors are required. Ceramic capacitors in the range 4.7μF to 10μF, placed as close to the IC pins, are recommended for the lower input and output ripple. The output capacitor voltage rating should be according to the V_{OUT} setting.

A feed forward capacitor C_F is required for stability. The recommended value (R₁ x C_F) is around 18μS. Some capacitors are suggested in the table below.

Capacitor Value	Vendor	Part Number
4.7μF	Panasonic	ECJ3YB1C475K
4.7μF	Murata	GRM31CR61C475

Table 2: Recommended Capacitors

Diode Selection

The external diode used for rectification is usually a Schottky diode. Its average forward current and reverse voltage maximum ratings should exceed the load current and the voltage at the output of the converter respectively. A barrier Schottky diode such as BAT54 is preferred, due to its lower reverse current over the temperature range.

Care should be taken to avoid any short circuit of V_{OUT} to GND, even with the IC disabled, since the diode can be instantly damaged by the excessive current.

Thermal Shutdown

When the die temperature exceeds 150°C, a reset occurs and will remain in effect until the die cools to 130°C, at that time the circuit will be allowed to restart.

PCB Layout Recommendations

The inherently high peak currents and switching frequency of power supplies require careful PCB layout design. Therefore, use wide traces for high current paths and place the input capacitor, the inductor, and the output capacitor as close as possible to the integrated circuit terminals. The resistor divider that sets the output voltage should be routed away from the inductor to avoid RF coupling. A four layer PCB with at least one ground plane connected to the pin 2 of the IC is recommended. This ground plane acts as an electromagnetic shield to reduce EMI and parasitic coupling between components.

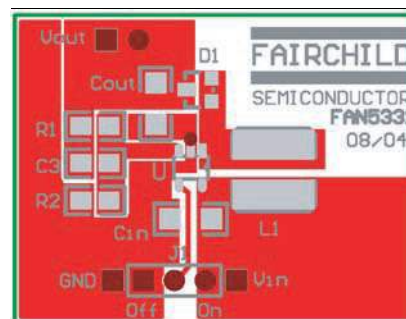

Figure 5. Recommended Layout

Application Examples

1. LED Driver

One or more serial LED strings can be driven with a constant current, set by the series resistor, given by

$$I_{LED} = \frac{1.23V}{R1}$$

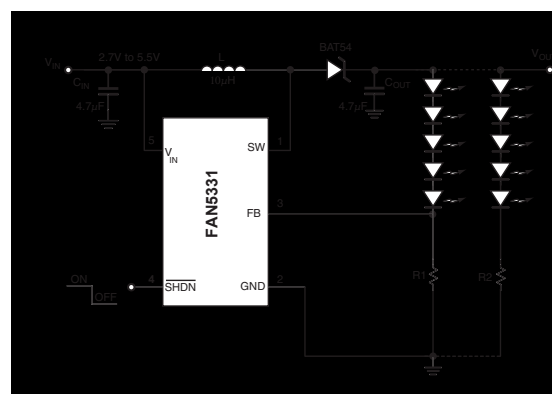
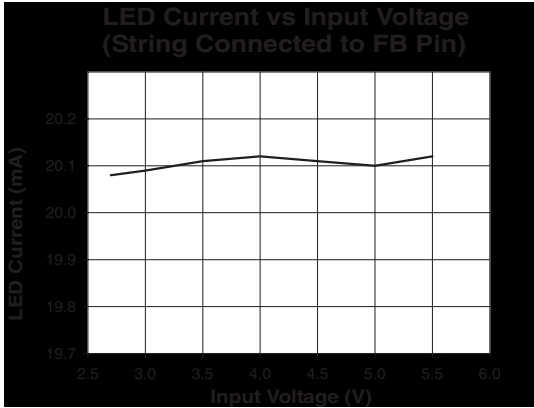

Figure 6. Low Noise Boost LED Driver



The feedback loop tightly regulates the current in the branch connected to FB pin, while the current in the other branch depends on the sum of the LED's forward voltages, V_{OUT} and the ballast resistor. The input and the output ripple is less than $3mV_{RMS}$, for load currents up to 40mA.

A Zener diode ($V_Z = 22V$) connected between V_{OUT} and GND can prevent the FAN5331 from being damaged by over-voltage, if the load is accidentally disconnected during operation.

2. Dual Boost Converter

A negative voltage can be provided by adding an external charge pump (C1, C2, D2, and D3).

While the feedback loop tightly regulates V_{OUT} , the negative output voltage ($-V_{OUT}$) can supply a light load with a negative voltage. Nevertheless, the negative voltage depends on the changes of the load current in both $-V_{OUT}$ and $+V_{OUT}$, as shown in the graph below.

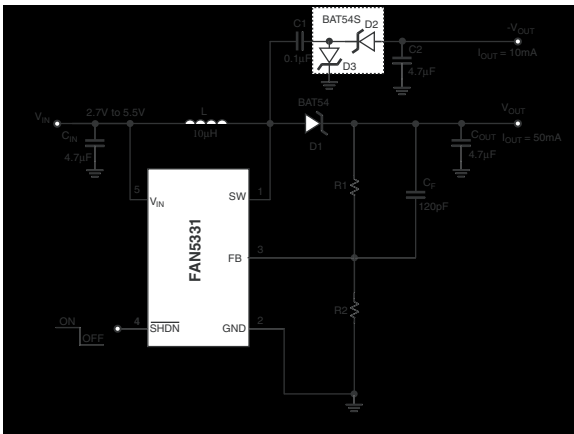
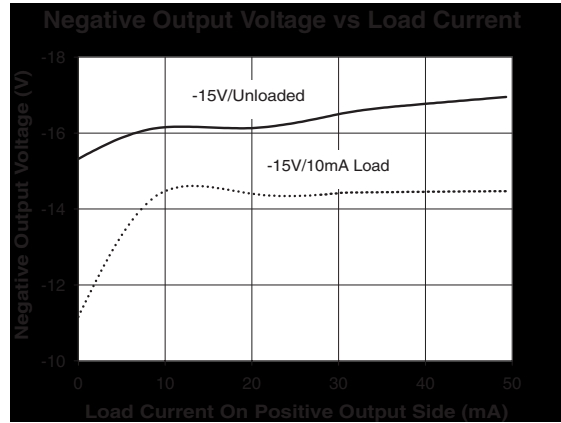
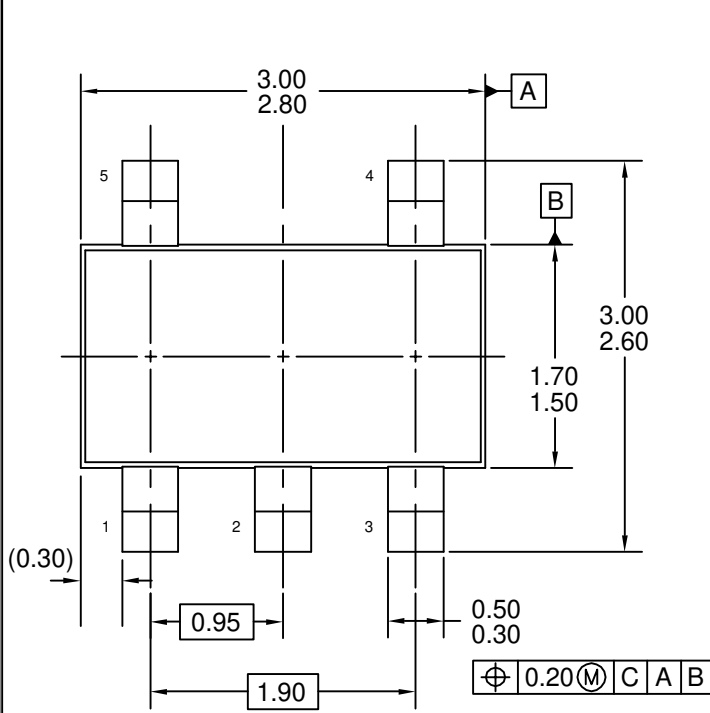
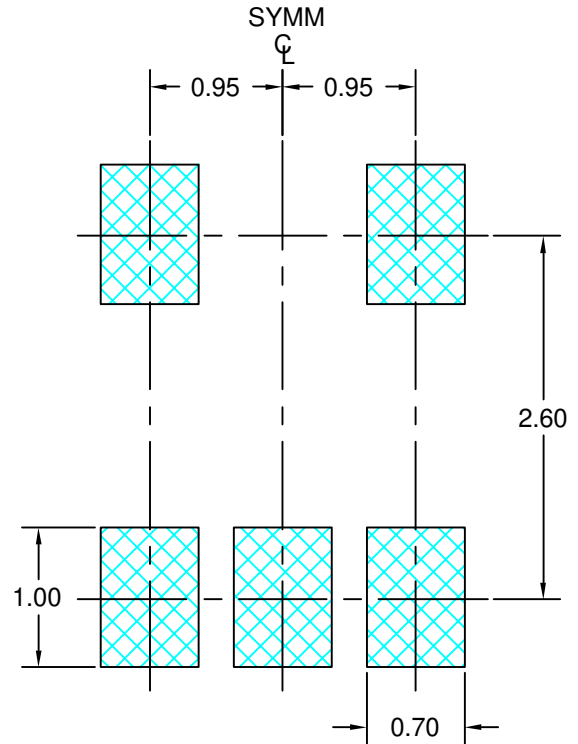

Figure 7. Dual (\pm) Boost Converter

REVISIONS			
LTR	DESCRIPTION	E.C.N.	DATE
A	RELEASE TO DOCUMENT CONTROL	11208	12/07/95
B	REDRAW PER CURRENT STANDARD	11531	07/31/96
C	REDRAW AS PER JEDEC NEW ISSUE FROM A TO B. CHANGE DRAWING TEMPLATE FROM LANDSCAPE TO PORTRAIT. CHANGE DIMENSION UNIT FROM INCHES TO MILLIMETERS.		
4	CHANGED BOTTOM VIEW TO TOP VIEW. REMOVED DATE FROM NOTES. ADDED NOTE C. CHANGED FONT STYLE		27 JUNE 07
5	BODY THICKNESS, TERMINAL THICKNESS, PACKAGE HEIGHT ADJUSTED TO MEET JEDEC STD		17 JULY 07



TOP VIEW



LAND PATTERN RECOMMENDATION

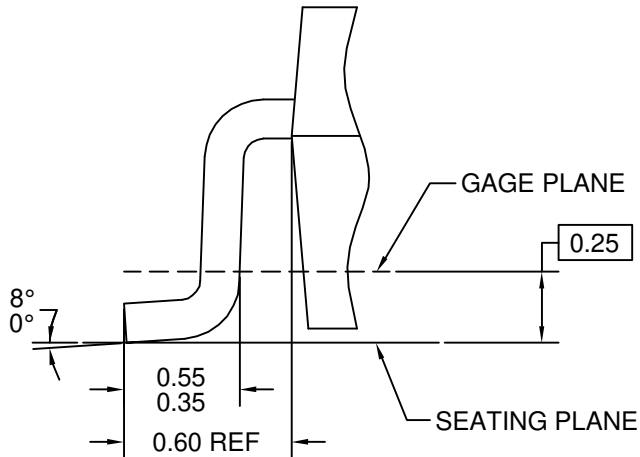
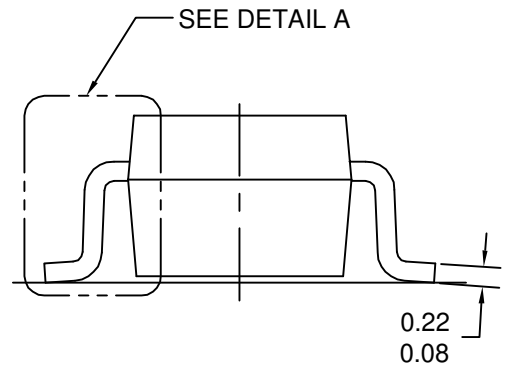
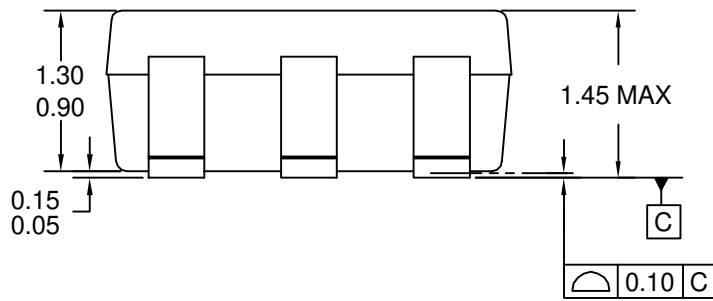

NOTES: UNLESS OTHERWISE SPECIFIED





- A) THIS PACKAGE CONFORMS TO JEDEC MO-178, ISSUE B, VARIATION AA,
- B) ALL DIMENSIONS ARE IN MILLIMETERS.
- C) MA05Brev5

APPROVALS	DATE	
DRAWN: L.HUEBENER CHECKED: H.ALLEN APPROVED:	17 JULY 07 19 JULY 07	
5LD,SOT23,JEDEC MO-178,1.6MM		SCALE: NA SIZE: NA DRAWING NUMBER: MKT-MA05B REV: 5
		FORMERLY: N/A SHEET: 1 OF 1



TRADEMARKS

The following includes registered and unregistered trademarks and service marks, owned by Fairchild Semiconductor and/or its global subsidiaries, and is not intended to be an exhaustive list of all such trademarks.

- | | | | |
|--|--|--|---|
| 2Cool™ | F-PFS™ | PowerTrench® | The Power Franchise® |
| AccuPower™ | FRFET® | PowerXS™ | the power franchise |
| AX-CAP™* | Global Power Resource™ | Programmable Active Droop™ | TinyBoost™ |
| BitSiC™ | GreenBridge™ | QFET® | TinyBuck™ |
| Build it Now™ | Green FPS™ | QS™ | TinyCalc™ |
| CorePLUS™ | Green FPS™ e-Series™ | Quiet Series™ | TinyLogic® |
| CorePOWER™ | Gmax™ | RapidConfigure™ | TINYOPTO™ |
| CROSSVOL™ | GTO™ |  ™ | TinyPower™ |
| CTL™ | IntelliMAX™ | Saving our world, 1mW/W/kW at a time™ | TinyPWM™ |
| Current Transfer Logic™ | ISOPLANAR™ | SignalWise™ | TinyWire™ |
| DEUXPEED® | Making Small Speakers Sound Louder and Better™ | SmartMax™ | TranSiC™ |
| Dual Cool™ | MegaBuck™ | SMART START™ | TriFault Detect™ |
| EcoSPARK® | MICROCOUPLER™ | Solutions for Your Success™ | TRUECURRENT®* |
| EfficientMax™ | MicroFET™ | SPM® | µSerDes™ |
| ESBC™ | MicroPak™ | STEALTH™ |  SerDes™ |
|  Fairchild® | MicroPak2™ | SuperFET® | UHC® |
| Fairchild Semiconductor® | MillerDrive™ | SuperSOT™-3 | Ultra FRFET™ |
| FACT Quiet Series™ | MotionMax™ | SuperSOT™-6 | UniFET™ |
| FACT® | Motion-SPM™ | SuperSOT™-8 | VCX™ |
| FAST® | mWSaver™ | SupreMOS® | VisualMax™ |
| FastvCore™ | OptoHiT™ | SyncFET™ | VoltagePlus™ |
| FETBench™ | OPTOLOGIC® | Sync-Lock™ | XS™ |
| FlashWriter®* | OPTOPLANAR® |  SYSTEM GENERAL®* | |
| FPS™ | | | |

* Trademarks of System General Corporation, used under license by Fairchild Semiconductor.

DISCLAIMER

FAIRCHILD SEMICONDUCTOR RESERVES THE RIGHT TO MAKE CHANGES WITHOUT FURTHER NOTICE TO ANY PRODUCTS HEREIN TO IMPROVE RELIABILITY, FUNCTION, OR DESIGN. FAIRCHILD DOES NOT ASSUME ANY LIABILITY ARISING OUT OF THE APPLICATION OR USE OF ANY PRODUCT OR CIRCUIT DESCRIBED HEREIN; NEITHER DOES IT CONVEY ANY LICENSE UNDER ITS PATENT RIGHTS, NOR THE RIGHTS OF OTHERS. THESE SPECIFICATIONS DO NOT EXPAND THE TERMS OF FAIRCHILD'S WORLDWIDE TERMS AND CONDITIONS, SPECIFICALLY THE WARRANTY THEREIN, WHICH COVERS THESE PRODUCTS.

LIFE SUPPORT POLICY

FAIRCHILD'S PRODUCTS ARE NOT AUTHORIZED FOR USE AS CRITICAL COMPONENTS IN LIFE SUPPORT DEVICES OR SYSTEMS WITHOUT THE EXPRESS WRITTEN APPROVAL OF FAIRCHILD SEMICONDUCTOR CORPORATION.

As used herein:

1. Life support devices or systems are devices or systems which, (a) are intended for surgical implant into the body or (b) support or sustain life, and (c) whose failure to perform when properly used in accordance with instructions for use provided in the labeling, can be reasonably expected to result in a significant injury of the user.
2. A critical component in any component of a life support, device, or system whose failure to perform can be reasonably expected to cause the failure of the life support device or system, or to affect its safety or effectiveness.

ANTI-COUNTERFEITING POLICY

Fairchild Semiconductor Corporation's Anti-Counterfeiting Policy. Fairchild's Anti-Counterfeiting Policy is also stated on our external website, www.fairchildsemi.com, under Sales Support.

Counterfeiting of semiconductor parts is a growing problem in the industry. All manufacturers of semiconductor products are experiencing counterfeiting of their parts. Customers who inadvertently purchase counterfeit parts experience many problems such as loss of brand reputation, substandard performance, failed applications, and increased cost of production and manufacturing delays. Fairchild is taking strong measures to protect ourselves and our customers from the proliferation of counterfeit parts. Fairchild strongly encourages customers to purchase Fairchild parts either directly from Fairchild or from Authorized Fairchild Distributors who are listed by country on our web page cited above. Products customers buy either from Fairchild directly or from Authorized Fairchild Distributors are genuine parts, have full traceability, meet Fairchild's quality standards for handling and storage and provide access to Fairchild's full range of up-to-date technical and product information. Fairchild and our Authorized Distributors will stand behind all warranties and will appropriately address any warranty issues that may arise. Fairchild will not provide any warranty coverage or other assistance for parts bought from Unauthorized Sources. Fairchild is committed to combat this global problem and encourage our customers to do their part in stopping this practice by buying direct or from authorized distributors.

PRODUCT STATUS DEFINITIONS

Definition of Terms

Datasheet Identification	Product Status	Definition
Advance Information	Formative / In Design	Datasheet contains the design specifications for product development. Specifications may change in any manner without notice.
Preliminary	First Production	Datasheet contains preliminary data; supplementary data will be published at a later date. Fairchild Semiconductor reserves the right to make changes at any time without notice to improve design.
No Identification Needed	Full Production	Datasheet contains final specifications. Fairchild Semiconductor reserves the right to make changes at any time without notice to improve the design.
Obsolete	Not In Production	Datasheet contains specifications on a product that is discontinued by Fairchild Semiconductor. The datasheet is for reference information only.

Rev. I61