



Features

- Greatly reduced maintenance
- Longer service life
- Tighter control over the operating voltage
- Reduced maintenance calls, fewer equipment failures and quieter lines
- Consistent performance



This series is currently available but not recommended for new designs.

BOURNS®

Model C-303™ 5-Pin Solid-State Protector Modules

Bourns® Model C-303™ 5-Pin Solid-State Protector Modules provide surge protection in a 5-pin type protector for use in central office connector, remote and building entrance terminal applications. The housings are made of colored self-extinguishing insulating material. The protector modules have five contact pins. When inserted into the connector sockets, contact pins provide the following connections for each cable pair:

- protection ground that also acts as a polarization pin
- tip and ring to the outside cable
- tip and ring to the central office equipment

Protector modules are available with gold-plated outside and central office pins; grounding pin is always tin-alloy plated.

- Protector modules with gold-plated pins are intended to be used in connectors with gold-plated protector receptacles.

The Bourns® Model C-303™ Solid-State Protector Module family greatly surpasses the performance of two- and three-element gas tubes as well as carbon, ensuring enhanced protection for sensitive switching equipment.

When the protector modules are fully inserted into the connector base, the outside plant and the central office pairs are connected together. Fast and easy disconnect of the central office pairs from the outside plant pairs is accomplished by pulling the fully inserted protector out to the “detent” position. Protection is still provided on the outside plant cable pairs.

The 5-pin module is designed to short-to-ground (also known as a “fail-short event”) when it encounters lightning, power cross or other electrical conditions that exceed the surge capabilities of the SSOVP device.

11- and 12-Type Protector Modules

The 11-type modules provide voltage protection to wiring and equipment. The 12-type modules provide voltage protection and are equipped with heat coils for applications where sneak current protection is required.

High-sensitivity heat coils protect digital equipment line cards against overheating caused by prolonged currents, commonly called sneak currents. Sneak currents may be caused by direct contact with low-voltage power lines or from induction on telephone lines caused by fault currents, overloads or unbalanced loads on nearby power lines. The 150 milliampere heat coils are sensitive enough to operate before component damage occurs on most digital line cards. They carry normal currents with ample safety margin and shunt potentially harmful sneak currents safely to ground.

Medium sensitivity (350 mA) and PBX battery (1.2 A) heat coils are also available.

Additional Information

Click these links for more information:



[PRODUCT](#)



[TECHNICAL LIBRARY](#)



[INVENTORY](#)



[SAMPLES](#)



[CONTACT](#)

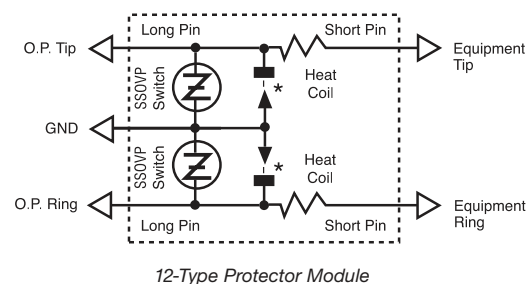
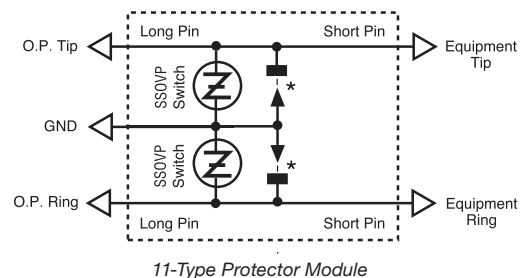

* Metallic shunts close circuit by heat coil operation to ground line and equipment directly or through heat coil resistance. Heat coil operates due to sneak currents and power crosses.



WARNING Cancer and Reproductive Harm - www.P65Warnings.ca.gov

Specifications are subject to change without notice.

Users should verify actual device performance in their specific applications.

The products described herein and this document are subject to specific legal disclaimers as set forth on the last page of this document, and at www.bourns.com/docs/legal/disclaimer.pdf.

Features (Continued)

- Sealed solid-state device to ensure long life even in hostile environments
- Fail-short device
-  Listed per UL 497 (File: E53117)
- Meets Telcordia GR-974

Model C-303™ 5-Pin Solid-State Protector Modules

BOURNS®

Specifications

Note: All SSOVP protector modules are CSA and UL Listed for subscriber premises applications.

DC Limiting Voltage	345 V max. @ 2000 V/s
AC Limiting Voltage (1K V _{rms} , 1 A _{rms} , 1 Cycle)	N/A
Leakage Current (Minimum Voltage Limit)	20 mA max. @ 265 VDC
Impulse Breakdown Voltage (Vimp)	390 V max. @ 100 V/μsec 400 V max. @ 1000 V/μsec 400 V max. @ 10,000 V/μsec
Insulation Resistance (IR)	100 megohms min. @ 50-200 VDC
DC Holdover (-20 °C to +65 °C)	20 msec max. @ 260 mA ±52 VDC @ 200 mA ±135 VDC @ 140 mA ±150 VDC
Service Life Surge	
±10 A, 10 x 1000 μsec	Unlimited
±100 A, 10 x 1000 μsec	Unlimited
±300 A, 10 x 1000 μsec	Fail-short
±10,000 A, 8 x 20 μsec	Fail-short
60 Hz RMS	
1 Amp for 1 second	60 surges, no-fail
10 Amps for 1 second	5 surges, no-fail
4, 10 and 30 Amps for 15 minutes	Fail-short
60 Amps for 3 seconds	Fail-short
120 Amps for 0.6 second	Fail-short
350 Amps for 0.04 second	Fail-short
Capacitance - Line to Ground.....	< 75 picofarads @ 0 VDC, 1 VAC, 1 MHz
On-State Voltage	< 10 V @ 100 Amps
Response Time.....	< 20 nanoseconds @ 10 kV/μsec
Storage Temperature.....	-40 °C to +65 °C
Safety Standard Listing	UL 497, CSA, Telcordia Specification GR-974

Sneak Current Protection Specifications

	150 mA Heat Coils (High Sensitivity)	350 mA Heat Coils (Medium Sensitivity)	1.2 A Heat Coils (PBX Battery)
Non-Operate.....	3 hours min. @ 150 mA.....	3 hours min. @ 350 mA.....	3 hours min. @ 1.2 A
Operate.....	210 seconds max. @ 250 mA	210 seconds max..... @ 540 mA	210 seconds max. @ 1.875 A
Resistance.....	19 ohms max.	4 ohms max.	0.32 ohms max.
Resistance Imbalance	1.0 ohms max.	0.5 ohms max.	--

Packaging Specifications

Standard Packaging	100 modules
Dimensions (H x W x D)	8 x 15 x 20 cm (3 x 6 x 8 in.)
Shipping Weight	1.8 kg (4 lb)

Specifications are subject to change without notice.

Users should verify actual device performance in their specific applications.

The products described herein and this document are subject to specific legal disclaimers as set forth on the last page of this document, and at www.bourns.com/docs/legal/disclaimer.pdf.

Model C-303™ 5-Pin Solid-State Protector Modules

BOURNS®

How to Order

5-Pin SSOVP Modules Equipped with Gold-Plated Pins, 300 V

Product Code	Part Number	Application	Description	Module Color	Type Number	Figure Number (see page 4)
3-Type Voltage Protection						
303M-11A1G0	A0341959	Standard Circuit		Black	3B1ES	1
303M-11A1Y0	303M-11A1Y0	Standard Circuit	Weather Sealed	Black		1
303M-11A2G0	A0342432	Service Denied		Green	3B2ES	1
303M-11A3G0	A0341960	Special Circuit		Red	3B3ES	1
303M-11A3Y0	303M-11A3Y0	Special Circuit	Weather Sealed	Red		1
303M-11A4G0	A0342435	PBX Battery		Yellow	3B4ES	1
303M-11A7G0	303M-11A7G0	Carrier Circuit		Blue		1
303M-11A7Y0	303M-11A7Y0	Standard Circuit	Weather Sealed	Blue		1
303M-11F1G0	A0365896	Standard Circuit	Front Test	Black	3C1ES	2
303M-11F2G0	A0365897	Service Denied	Front Test	Green	3C2ES	2
303M-11F3G0	A0365898	Special Circuit	Front Test	Red	3C3ES	2
303M-11F4G0	A0370522	PBX Battery	Front Test	Yellow	3C4ES	2
303M-11F7G0	303M-11F7G0	Carrier Circuit	Front Test	Blue		2
4-Type Voltage and Sneak Current Protection (150 mA Heat Coils)						
303M-12A1GE	A0366039	Standard Circuit		Black	4B1ES	3
303M-12A3GE	A0366042	Special Circuit		Red	4B3ES	3
303M-12A9GE	A0366045	Tip/Ring Reverse*		White	4B9ES	3
303M-12F1GE	A0365905	Standard Circuit	Front Test	Black	4C1ES	4
303M-12F3GE	A0365906	Special Circuit	Front Test	Red	4C3ES	4
303M-12F9GE	A0365908	Tip/Ring Reverse*	Front Test	White	4C9ES	4
4-Type Voltage and Sneak Current Protection (350 mA and 1.2 A Heat Coils)						
303M-12A1GA	A0353716	Standard Circuit	350 mA Heat Coil	Black	4B1ESC	3
303M-12A1YA	303M-12A1YA	Standard Circuit	350 mA Heat Coil, Weather Sealed	Black		3
303M-12A2G0	A0353725	Service Denied	(No Heat Coil)	Green	4B2ES	3
303M-12A3GA	A0353717	Special Circuit	350 mA Heat Coil	Red	4B3ESC	3
303M-12A3YA	303M-12A3YA	Special Circuit	Weather Sealed	Red		3
303M-12A4GF	A0353726	PBX Battery	1.2 A Heat Coil	Yellow	4B4ES	3
303M-12A7GA	303M-12A7GA	Carrier Circuit	350 mA Heat Coil	Blue	4B7ES	3
303M-12A9GA	A0353727	Tip/Ring Reverse*	350 mA Heat Coil	White	4B9ESC	3
303M-12F1GA	A0361533	Standard Circuit	350 mA Heat Coil Front Test	Black	4C1ESC	4
303M-12F2G0	A0358452	Service Denied	(No Heat Coil) Front Test	Green	4C2ES	4
303M-12F3GA	A0361534	Special Circuit	350 mA Heat Coil Front Test	Red	4C3ESC	4
303M-12F4GF	A0361919	PBX Battery	1.2 A Heat Coil Front Test	Yellow	4C4ES	4
303M-12F9GA	A0361535	Tip/Ring Reverse*	350 mA Heat Coil Front Test	White	4C9ESC	4

* Pair reversing protector units: These units identify and correct reversed pairs in the outside plant. Reversing protector units are intended for temporary use until the reversed pairs can be rewired correctly.

Note: Order by Part Number.

Specifications are subject to change without notice.

Users should verify actual device performance in their specific applications.

The products described herein and this document are subject to specific legal disclaimers as set forth on the last page of this document, and at www.bourns.com/docs/legal/disclaimer.pdf.

Model C-303™ 5-Pin Solid-State Protector Modules

BOURNS®

Product Dimensions

Figure 1
11A-Type Protector

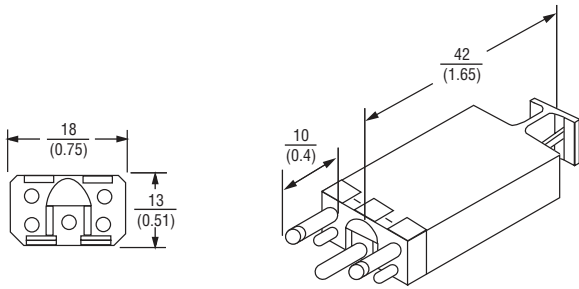

Figure 2
11F-Type Protector

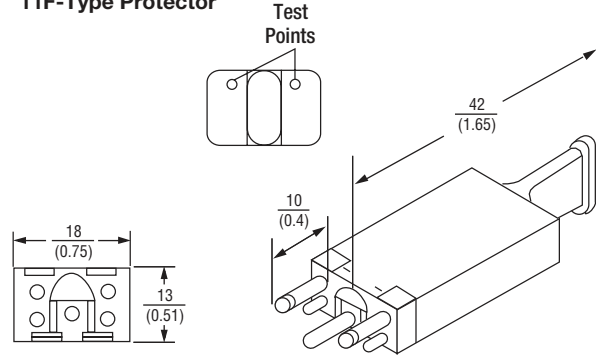

Figure 3
12A-Type Protector

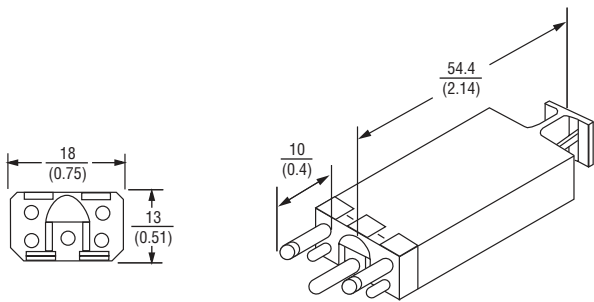
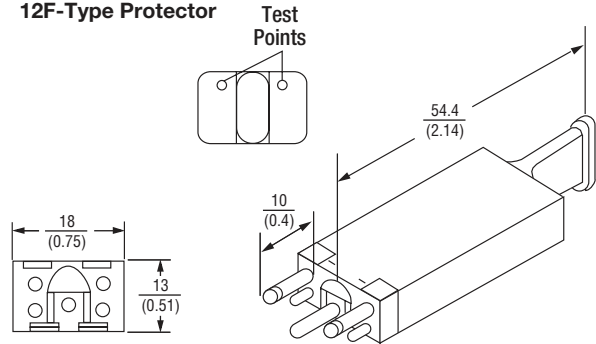

Figure 4
12F-Type Protector



DIMENSIONS: $\frac{\text{MM}}{\text{(INCHES)}}$

REV. M 02/23

Specifications are subject to change without notice.

Users should verify actual device performance in their specific applications.

The products described herein and this document are subject to specific legal disclaimers as set forth on the last page of this document, and at www.bourns.com/docs/legal/disclaimer.pdf.

This legal disclaimer applies to purchasers and users of Bourns® products manufactured by or on behalf of Bourns, Inc. and its affiliates (collectively, "Bourns").

Unless otherwise expressly indicated in writing, Bourns® products and data sheets relating thereto are subject to change without notice. Users should check for and obtain the latest relevant information and verify that such information is current and complete before placing orders for Bourns® products.

The characteristics and parameters of a Bourns® product set forth in its data sheet are based on laboratory conditions, and statements regarding the suitability of products for certain types of applications are based on Bourns' knowledge of typical requirements in generic applications. The characteristics and parameters of a Bourns® product in a user application may vary from the data sheet characteristics and parameters due to (i) the combination of the Bourns® product with other components in the user's application, or (ii) the environment of the user application itself. The characteristics and parameters of a Bourns® product also can and do vary in different applications and actual performance may vary over time. Users should always verify the actual performance of the Bourns® product in their specific devices and applications, and make their own independent judgments regarding the amount of additional test margin to design into their device or application to compensate for differences between laboratory and real world conditions.

Unless Bourns has explicitly designated an individual Bourns® product as meeting the requirements of a particular industry standard (e.g., ISO/TS 16949) or a particular qualification (e.g., UL listed or recognized), Bourns is not responsible for any failure of an individual Bourns® product to meet the requirements of such industry standard or particular qualification. Users of Bourns® products are responsible for ensuring compliance with safety-related requirements and standards applicable to their devices or applications.

Bourns® products are not recommended, authorized or intended for use in nuclear, lifesaving, life-critical or life-sustaining applications, nor in any other applications where failure or malfunction may result in personal injury, death, or severe property or environmental damage. Unless expressly and specifically approved in writing by two authorized Bourns representatives on a case-by-case basis, use of any Bourns® products in such unauthorized applications might not be safe and thus is at the user's sole risk. Life-critical applications include devices identified by the U.S. Food and Drug Administration as Class III devices and generally equivalent classifications outside of the United States.

Bourns expressly identifies those Bourns® standard products that are suitable for use in automotive applications on such products' data sheets in the section entitled "Applications." Unless expressly and specifically approved in writing by two authorized Bourns representatives on a case-by-case basis, use of any other Bourns® standard products in an automotive application might not be safe and thus is not recommended, authorized or intended and is at the user's sole risk. If Bourns expressly identifies a sub-category of automotive application in the data sheet for its standard products (such as infotainment or lighting), such identification means that Bourns has reviewed its standard product and has determined that if such Bourns® standard product is considered for potential use in automotive applications, it should only be used in such sub-category of automotive applications. Any reference to Bourns® standard product in the data sheet as compliant with the AEC-Q standard or "automotive grade" does not by itself mean that Bourns has approved such product for use in an automotive application.

Bourns® standard products are not tested to comply with United States Federal Aviation Administration standards generally or any other generally equivalent governmental organization standard applicable to products designed or manufactured for use in aircraft or space applications. Bourns expressly identifies Bourns® standard products that are suitable for use in aircraft or space applications on such products' data sheets in the section entitled "Applications." Unless expressly and specifically approved in writing by two authorized Bourns representatives on a case-by-case basis, use of any other Bourns® standard product in an aircraft or space application might not be safe and thus is not recommended, authorized or intended and is at the user's sole risk.

The use and level of testing applicable to Bourns® custom products shall be negotiated on a case-by-case basis by Bourns and the user for which such Bourns® custom products are specially designed. Absent a written agreement between Bourns and the user regarding the use and level of such testing, the above provisions applicable to Bourns® standard products shall also apply to such Bourns® custom products.

Users shall not sell, transfer, export or re-export any Bourns® products or technology for use in activities which involve the design, development, production, use or stockpiling of nuclear, chemical or biological weapons or missiles, nor shall they use Bourns® products or technology in any facility which engages in activities relating to such devices. The foregoing restrictions apply to all uses and applications that violate national or international prohibitions, including embargos or international regulations. Further, Bourns® products and Bourns technology and technical data may not under any circumstance be exported or re-exported to countries subject to international sanctions or embargoes. Bourns® products may not, without prior authorization from Bourns and/or the U.S. Government, be resold, transferred, or re-exported to any party not eligible to receive U.S. commodities, software, and technical data.

To the maximum extent permitted by applicable law, Bourns disclaims (i) any and all liability for special, punitive, consequential, incidental or indirect damages or lost revenues or lost profits, and (ii) any and all implied warranties, including implied warranties of fitness for particular purpose, non-infringement and merchantability.

For your convenience, copies of this Legal Disclaimer Notice with German, Spanish, Japanese, Traditional Chinese and Simplified Chinese bilingual versions are available at:

Web Page: <http://www.bourns.com/legal/disclaimers-terms-and-policies>

PDF: <http://www.bourns.com/docs/Legal/disclaimer.pdf>