

1.5A, 18V, 500kHz ACOT™ Synchronous Step-down Converter

Purpose

The RT7255 is an Advanced Constant On-Time (ACOT™) mode control synchronous step-down converter with the input voltage range from 4.3V to 18V and provides 1.5A output current. This document explains the function and use of the RT7255 evaluation board (EVB), and provides information to enable operation, modification of the evaluation board and circuit to suit individual requirements.

Table of Contents

Purpose.....	1
Introduction.....	2
Key Performance Summary Table.....	2
Bench Test Setup Conditions.....	3
Schematic, Bill of Materials & Board Layout.....	5
More Information.....	8
Important Notice for Richtek Evaluation Board.....	8

Introduction

General Product Information

The RT7255 is a synchronous step-down converter with Advanced Constant On-Time (ACOT™) mode control. The ACOT™ provides a very fast transient response with few external components. The low impedance internal MOSFET supports high efficiency operation with wide input voltage range from 4.3V to 18V. The proprietary circuit of the RT7255 supports all ceramic capacitors.

Product Feature

- 4.3V to 18V Input Voltage Range
- Adjustable Soft-Start Time
- PGOOD Function
- 1.5A Output Current
- Advanced Constant On-Time Control
- Fast Transient Response
- Support All Ceramic Capacitors
- Up to 95% Efficiency
- 500kHz Switching Frequency
- Adjustable Output Voltage from 0.6V to 8V
- Cycle-by-Cycle Current Limit
- Input Under-Voltage Lockout
- Hiccup Mode Under-Voltage Protection
- Thermal Shutdown

Key Performance Summary Table

Key Features	Evaluation Board Number : PCB037_V1
Default Input Voltage	12V
Max Output Current	1.5A
Default Output Voltage	1.2V
Default Marking & Package Type	RT7255AGV8, SOT-23-8
Operation Frequency	Fixed 500kHz

Bench Test Setup Conditions

Headers Description and Placement

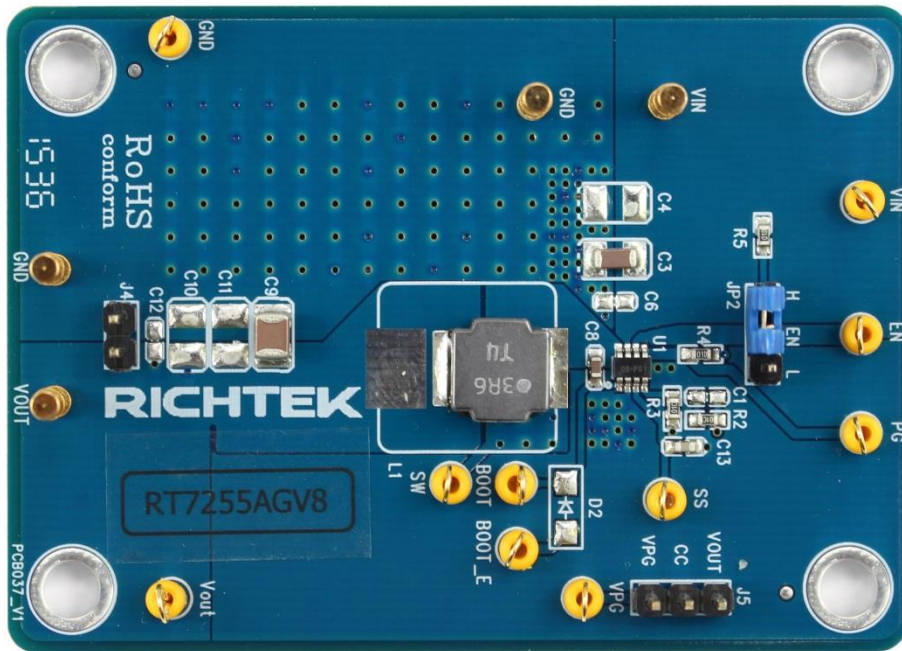

Please carefully inspect the EVB IC and external components, comparing them to the following Bill of Materials, to ensure that all components are installed and undamaged. If any components are missing or damaged during transportation, please contact the distributor or send e-mail to evb_service@richtek.com

Test Points

The EVB is provided with the test points and pin names listed in the table below.

Test point/Pin name	Signal	Comment (expected waveforms or voltage levels on test points)
VIN	Input voltage	Power input. The input voltage range is from 4.3V to 18V. Must bypass with a suitable large ceramic capacitor at this pin.
EN	Enable test point	Enable control input. Connect EN to a logic-high voltage to enable the IC or to a logic-low voltage to disable. Do not leave this high impedance input unconnected.
GND	Ground	Power ground.
BOOT		Bootstrap supply for high-side gate driver. Connect a 1 μ F ceramic capacitor between the BOOT and SW pins.
FB	Feedback	Feedback voltage input. The pin is used to set the output voltage of the converter via a resistive divider. The converter regulates V_{FB} to 0.6V.
SW	Switch node test point	Switch node.
PGOOD	Power good test point	Power good indicator output.
SS	Soft-start test point	Soft-start time setting. Connect a capacitor from SS to GND to set the soft-start period.

Power-up & Measurement Procedure

1. Apply a 12V nominal input power supply ($4.3V < V_{IN} < 18V$) to the VIN and GND terminals.
2. Set the jumper at JP2 to connect terminals 2 and 3, connecting EN to enable operation.
3. Verify the output voltage (approximately 1.2V) between VOUT and GND.
4. Connect an external load up to 1.5A to the VOUT and GND terminals and verify the output voltage and current.

Output Voltage Setting

Set the output voltage with the resistive divider (R2, R3) between VOUT and GND with the midpoint connected to FB. The output is set by the following formula :

$$V_{OUT} = 0.6 \times \left(1 + \frac{R2}{R3}\right)$$

Schematic, Bill of Materials & Board Layout

EVB Schematic Diagram

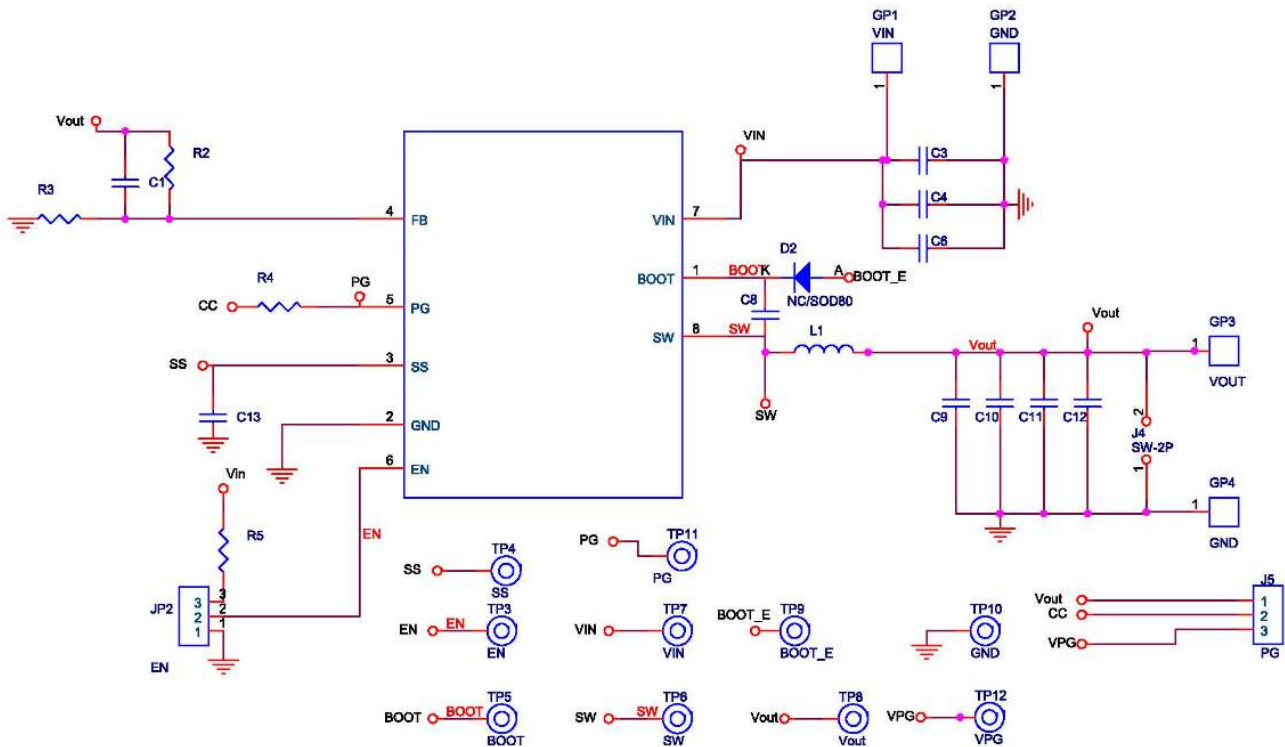

Bill of Materials

Reference	Qty	Part Number	Description	Package	Manufacture
U1	1	RT7255AGV8	DC/DC Converter	SOT-23-8	RICHTEK
C3	1	GRM31CR71E106KA12L	10 μ F/25V/X5R	C-1206	MURATA
C8	1	C1608X7R1H104K080AA	1 μ F/25V/X5R	C-0603	MURATA
C4, C6, C10, C11, C12, C1, D2	7		N/A		
C9	1	GRM32ER61C226KE20L	22 μ F/16V/X7R	C-1210	MURATA
R4, R5	2		10k	R-0603	
C13	1	0603B103K500	10nF/50V/X7R	C-0603	WALSIN
R2	1		10k	R-0603	
R3	1		10k	R-0603	
L1	1	NR8040T3R6N	3.6 μ H/4.9A	8 x 8 mm	TAIYO YUDEN

PCB Layout

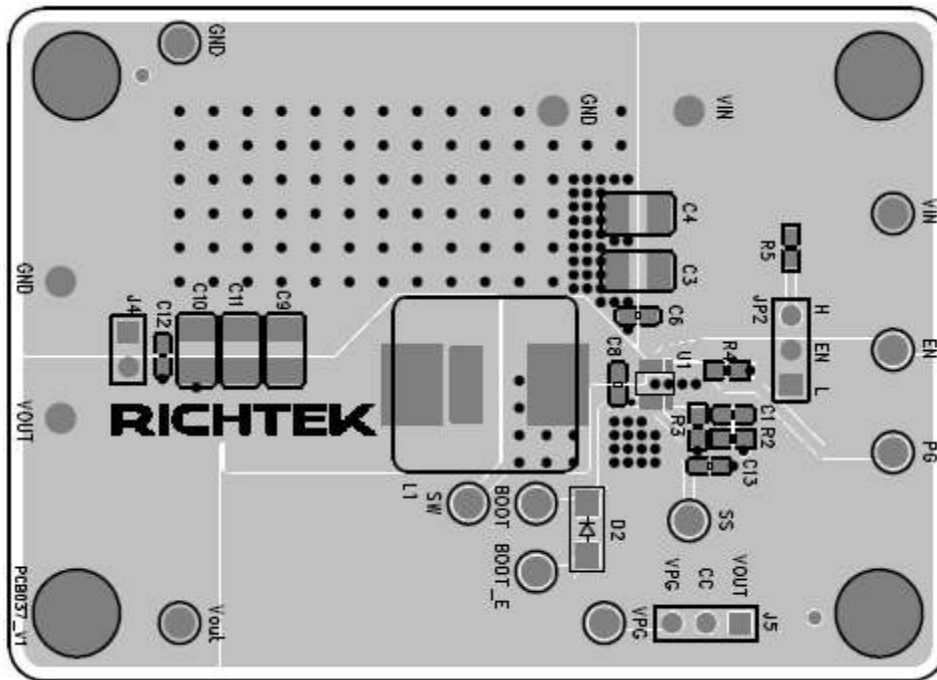

Top View (1st layer)

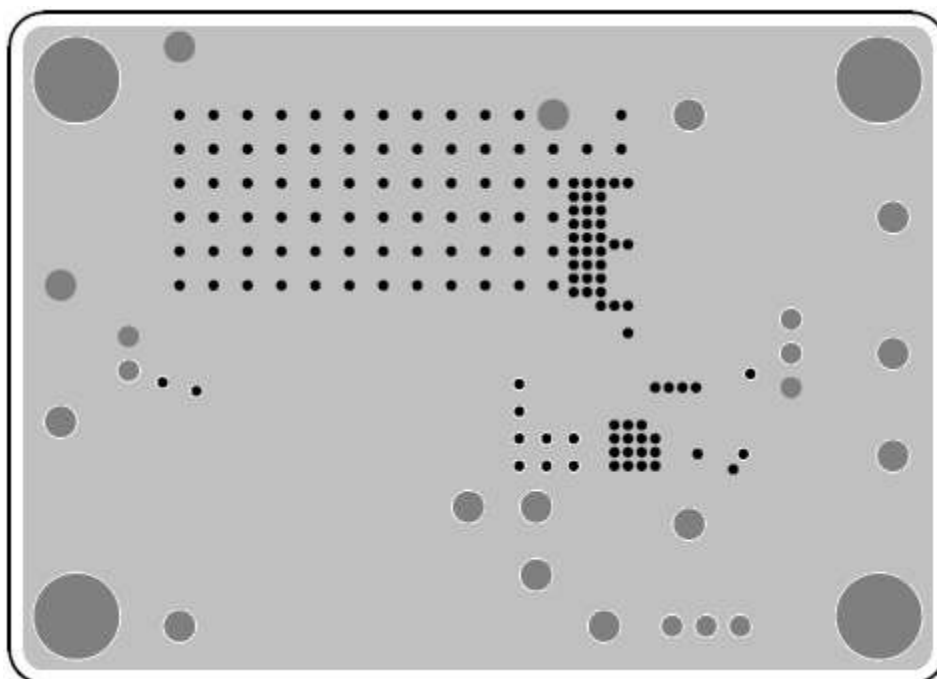

PCB Layout—Inner Side (2nd Layer)

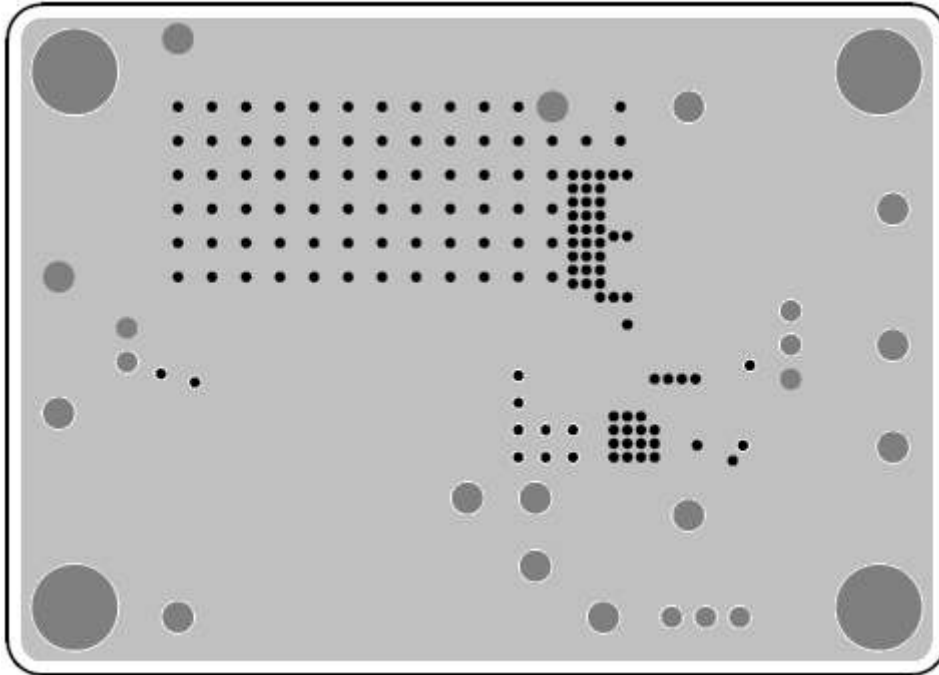

PCB Layout—Inner Side (3rd Layer)

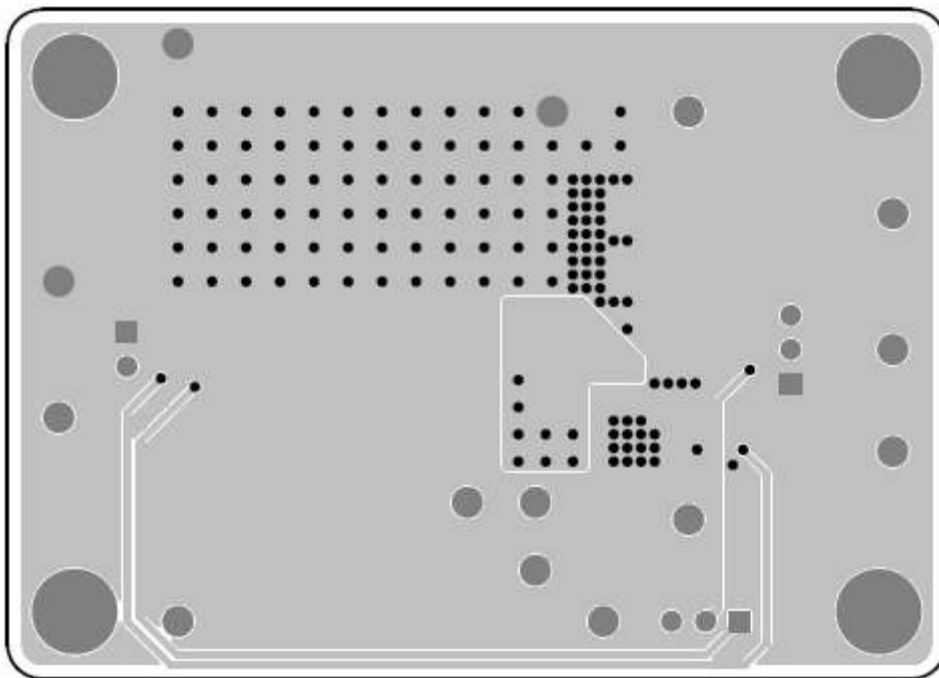

Bottom View (4th Layer)

More Information

For more information, please find the related datasheet or application notes from Richtek website <http://www.richtek.com>.

Important Notice for Richtek Evaluation Board

THIS DOCUMENT IS FOR REFERENCE ONLY, NOTHING CONTAINED IN THIS DOCUMENT SHALL BE CONSTRUED AS RICHTEK'S WARRANTY, EXPRESS OR IMPLIED, UNDER CONTRACT, TORT OR STATUTORY, WITH RESPECT TO THE PRESENTATION HEREIN. IN NO EVENT SHALL RICHTEK BE LIABLE TO BUYER OR USER FOR ANY AND ALL DAMAGES INCLUDING WITHOUT LIMITATION TO DIRECT, INDIRECT, SPECIAL, PUNITIVE OR CONSEQUENTIAL DAMAGES.