



# PRODUCT SPECIFICATION

## SPOX BMI CONNECTOR SYSTEM

### 1.0 SCOPE

This Product Specification covers the 2.50 mm (.098 inch) centerline (pitch) connector series terminated with 22 to 28 AWG wire using Crimp technology with tin plating.

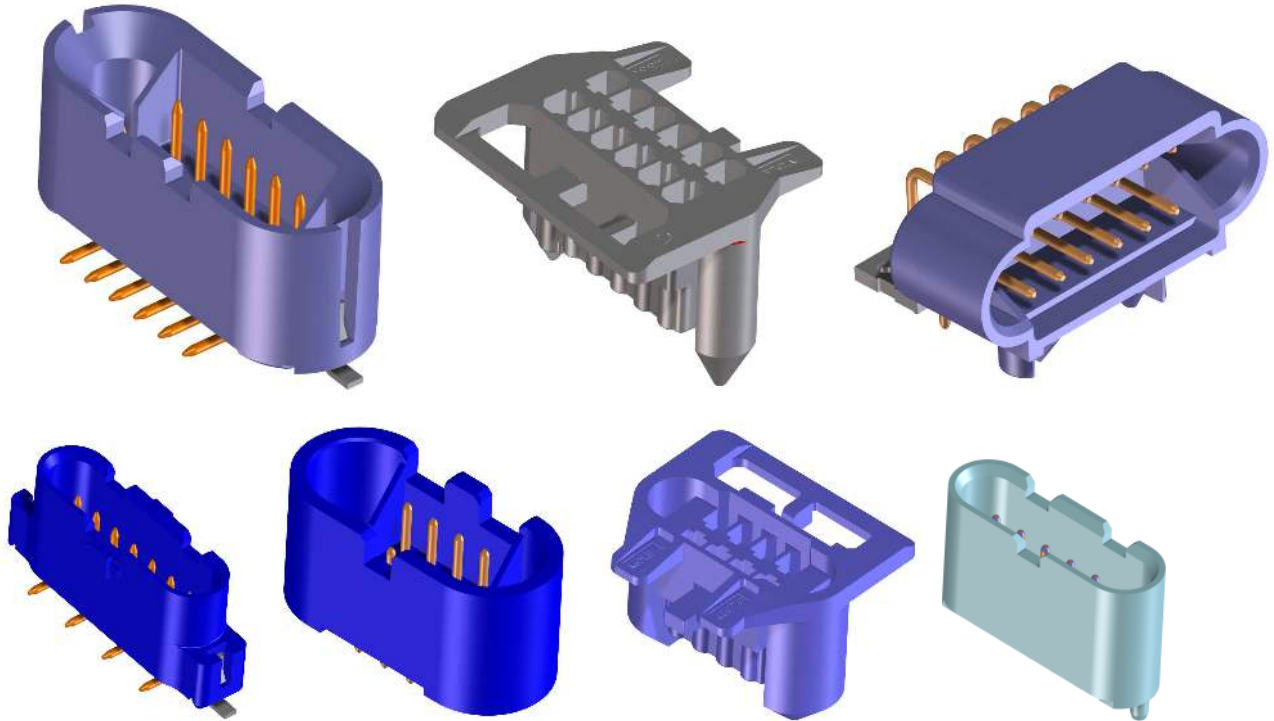

REVISION: <b>F</b>	ECR/ECN INFORMATION: EC No: <b>UCP2012-3935</b> DATE: <b>12/19/12</b>	TITLE: <b>PRODUCT SPECIFICATION SPOX BMI</b>	SHEET No. <b>1 of 5</b>
DOCUMENT NUMBER: <b>PS-45579-001</b>	CREATED / REVISED BY: <b>ROSCA</b>	CHECKED BY: <b>COMERCI</b>	APPROVED BY: <b>COMERCI</b>



# PRODUCT SPECIFICATION

## 2.0 PRODUCT DESCRIPTION

### 2.1 PRODUCT NAME AND SERIES NUMBER (S)

Crimp Terminal Female (for 45579, 45609 housing)	5263
Crimp Terminal Male (for 45626 housing)	45627
Crimp Housing Rear-Entry Panel Mount Blindmate Recept. 6 Pin	45579 (mates to 45626)
Vertical Blindmate Header, 6 Pin	45578 (mates to 45579)
Vertical Blindmate Plug, 6 Pin	45626 (mates to 45579)
Crimp Housing Rear-Entry Panel Mount Blindmate Recept. 16 Pin	45609 (mates to 45608)
Right Angle Blindmate Header 16 Pin	45608 (mates to 45609)
Vertical Blindmate Header, 1x6 Pin	46511 (mates to 46528)
Vertical Blindmate Plug, 1x6 Pin	46528 (mates to 46511)
Vertical Blindmate Plug, 1x7 Pin	46528 (mates to 46781)
Housing Rear-Entry Panel Mount Blindmate Recept. 12 Pin	45609 (mates to 45608)
Right Angle Blindmate Header 12 Pin	45608 (mates to 45609)
Vertical Blindmate Header Lead-in 6 Pin	171056 (mates to 46528)
SMT Vertical Header 1x7 Pin	46781 (mates to 46528)
SMT Vertical Header 2x6 Pin	171654 (mates to 45609)

### 2.2 DIMENSIONS, MATERIALS, PLATINGS AND MARKINGS

Receptacle housing: polyester, black

Header housing: LCP, black

Terminals: Post-plated phos. Bronze, tin over nickel plating

Pins: Brass, tin over nickel plating

### 2.3 SAFETY AGENCY APPROVALS

UL Number - E29179

CSA Number - LR 19980

## 3.0 APPLICABLE DOCUMENTS AND SPECIFICATIONS

Wire Termination Specification: 638616000

## 4.0 RATINGS

### 4.1 VOLTAGE

250 Volts AC (RMS) {or 176 Volts DC}

**4.2 CURRENT AND APPLICABLE WIRES** (Current is dependent on connector size, contact material, plating, ambient temperature, printed circuit board characteristics and related factors. Actual current rating is application dependent and should be evaluated for each application.)

AWG	Amps	Outside Insulation Diameter
22	3.0	1.15 – 1.9 mm (.045 - .075 inch)
24	2.5	1.15 – 1.9 mm (.045 - .075 inch)

<b>REVISION:</b> <b>F</b>	<b>ECR/ECN INFORMATION:</b> EC No: <b>UCP2012-3935</b> DATE: <b>12/19/12</b>	<b>TITLE:</b> <b>PRODUCT SPECIFICATION</b> <b>SPOX BMI</b>	<b>SHEET No.</b> <b>2 of 5</b>
<b>DOCUMENT NUMBER:</b> <b>PS-45579-001</b>	<b>CREATED / REVISED BY:</b> <b>ROSCA</b>	<b>CHECKED BY:</b> <b>COMERCI</b>	<b>APPROVED BY:</b> <b>COMERCI</b>



# PRODUCT SPECIFICATION

26	2.0	1.15 – 1.9 mm (.045 - .075 inch)
28	1.5	1.15 – 1.9 mm (.045 - .075 inch)

### 4.3 TEMPERATURE (ambient +30° temp rise)

Operating: 0°C to + 75°C  
 Nonoperating: - 40°C to + 105°C

## 5.0 PERFORMANCE

### 5.1 ELECTRICAL REQUIREMENTS

ITEM	DESCRIPTION	TEST CONDITION	REQUIREMENT
1	<b>Contact Resistance (Low Level)</b>	EIA-364-23 (termination of connector to board will be included in measurement) Mate connectors: apply a maximum voltage of 20 mV and a current of 100 mA.	<b>20 milliohms MAXIMUM</b> [initial]
2	<b>Insulation Resistance</b>	Unmate & unmount connectors: apply a voltage of 500 VDC between adjacent terminals and between terminals to ground.	<b>1000 Megohms MINIMUM</b>
3	<b>Temperature Rise (via Current Cycling)</b>	Mate connectors: measure the temperature rise at the rated current after: 1.) 96 hours (steady state) 2.) 240 hours (45 minutes ON and 15 minutes OFF per hour). 3.) 96 hours (steady state)	Temperature rise: <b>+30°C MAXIMUM</b>
4	<b>Dielectric Withstanding Voltage</b>	EIA-364-20 Unmate connectors: apply a voltage of {two times the rated voltage plus 1000 volts} VAC for 1 minute between adjacent terminals and between terminals to ground.	No disruptive discharge current leakage < 5 mA
5	<b>Contact Resistance on Crimped Portion</b>	Crimp the applicable wire on to the terminal, measure by dry circuit, 20mV MAX., 10mA.	<b>5 milliohms MAX.</b>

REVISION: <b>F</b>	ECR/ECN INFORMATION: EC No: <b>UCP2012-3935</b> DATE: <b>12/19/12</b>	TITLE: <b>PRODUCT SPECIFICATION SPOX BMI</b>	SHEET No. <b>3 of 5</b>
DOCUMENT NUMBER: <b>PS-45579-001</b>	CREATED / REVISED BY: <b>ROSCA</b>	CHECKED BY: <b>COMERCI</b>	APPROVED BY: <b>COMERCI</b>



# PRODUCT SPECIFICATION

## 5.2 MECHANICAL REQUIREMENTS

ITEM	DESCRIPTION	TEST CONDITION	REQUIREMENT
1	<b>Terminal Mate and Unmate Forces</b> <i>Female terminal lubricated (502J)</i>	Mate and unmate terminal (male to female) at a rate of 25 ± 6 mm (1 ± ¼ inch) per minute.	7 N (1.6 lbf) max mate 5 N (1.1 lbf) max unmate 2 N (0.4 lbf) min unmate <i>Values shown are per terminal</i>
2	<b>Crimp Terminal Insertion Force</b>	Insert the crimp terminal into the housing	15 N (3 lbf) Maximum insertion force
3	<b>Crimp Terminal Retention Force (in housing)</b>	Axial pullout force on the terminal in the housing at a rate of 25 ± 6 mm (1 ± ¼ inch) per minute	15 N (3 lbf) Minimum retention force
4	<b>Header Pin Retention Force (in housing)</b>	Apply axial push force at the speed rate 25 ± 3 mm / minute.	9 N (2 lbf) Minimum retention force
5	<b>Contact Wipe</b>	RSS calculated min. contact wipe	1.60mm Min. wire to wire 2.30mm Min wire to board
6A	<b>Panel Mount Retention of 45579</b>	Metal panel per RSD-45579-001, location of connection within the panel yielding the lowest retention force applied in the center at 25 ± 6 mm per minute.	133 N 30 lbf min.
6B	<b>Panel Mount Retention of 45626</b>	Metal panel per RSD-45626-001, location of connection within the panel yielding the lowest retention force applied in the center at 25 ± 6 mm per minute.	133 N 30 lbf min.

REVISION: <b>F</b>	ECR/ECN INFORMATION: EC No: <b>UCP2012-3935</b> DATE: <b>12/19/12</b>	TITLE: <b>PRODUCT SPECIFICATION SPOX BMI</b>	SHEET No. <b>4 of 5</b>
DOCUMENT NUMBER: <b>PS-45579-001</b>	CREATED / REVISED BY: <b>ROSCA</b>	CHECKED BY: <b>COMERCI</b>	APPROVED BY: <b>COMERCI</b>



# PRODUCT SPECIFICATION

## 5.2 MECHANICAL REQUIREMENTS

ITEM	DESCRIPTION	TEST CONDITION	REQUIREMENT
6C	Panel Mount Retention of 45609	Metal panel per RSD-45609-001, location of connection within the panel yielding the lowest retention force applied in the center at $25 \pm 6$ mm per minute.	133 N 30 lbf min.
7	PCB Peg Insertion & Retention In PC Board (45608)	Apply axial push force at the speed rate $25 \pm 6$ mm per minute.	45 N (10 lbf) Maximum Insertion Force 27 N (6 lbf) Minimum Retention Force
8	Durability	EIA-364-09 Mate connectors 25 cycles for tin maximum rate of 10 cycles per minute prior to Environmental Tests.	10 milliohms Maximum (change from initial) No evidence of physical Damage
9	Vibration (Random)	Mate connectors and vibrate per EIA 364-28, test condition VII, test condition letter D (15 min. in each of 3 mutual perpendicular directions. Both mating halves should be rigidly fixed so as not to contribute to the relative motion of one contact against another.	10 milliohms Maximum (change from initial) & Discontinuity < 1 microsecond
10	Shock (Mechanical)	Mate connectors and shock at 50 g's with $\frac{1}{2}$ sine wave (11 milliseconds) shocks in the $\pm X$ , $\pm Y$ , $\pm Z$ axes (18 shocks total).	10 milliohms Maximum (change from initial) & Discontinuity < 1 microsecond
11	Crimp Wire Pullout Force (Axial)	Fix the crimped terminal, apply axial pull out force on the wire at the speed rate of $25 \pm 3$ / minute. (JIS C5402 6.8)	AWG. #22 39 N (9 lbf) MINIMUM pullout force
			AWG. #24 29 N (6 lbf) MINIMUM pullout force
			AWG. #26 19 N (4 lbf) MINIMUM pullout force
			AWG. #28 9 N (2 lbf) MINIMUM pullout force

REVISION: <b>F</b>	ECR/ECN INFORMATION: EC No: UCP2012-3935 DATE: 12/19/12	TITLE: <b>PRODUCT SPECIFICATION SPOX BMI</b>	SHEET No. <b>5 of 5</b>
DOCUMENT NUMBER: <b>PS-45579-001</b>	CREATED / REVISED BY: <b>ROSCA</b>	CHECKED BY: <b>COMERCI</b>	APPROVED BY: <b>COMERCI</b>



# PRODUCT SPECIFICATION

## 5.3 ENVIRONMENTAL REQUIREMENTS

ITEM	DESCRIPTION	TEST CONDITION	REQUIREMENT
1	Shock (Thermal)	EIA 364-32 condition I Mate connectors; expose to 5 cycles of: <u>Temperature °C</u> <u>Duration (Minutes)</u> -55 +0/-3              30 +25 ±10                5 MAXIMUM +85 +3/-0              30 +25 ±10                5 MAXIMUM	10 milliohms MAXIMUM (change from initial) & Visual: No Damage
2	Temp Life	EIA 364-17 Mate connectors; expose to: 96 hours at 105 ± 2°C	10 milliohms MAXIMUM (change from initial]) & Visual: No Damage
3	Humidity (Cyclic)	EIA-364-31 24 cycles at temperature 25 ± 3°C at 80 ± 3% relative humidity and 65 ± 3°C at 50 ± 3% relative humidity; dwell time of 1.0 hour; ramp time of 0.5 hours. Dwell times start when the temperature and humidity have stabilized within the specified levels.	10 milliohms MAXIMUM (change from initial) & Dielectric Withstanding Voltage: No Breakdown at 500 VAC & Insulation Resistance: 1000 Megohms MINIMUM & Visual: No Damage

## 6.0 PACKAGING

Bulk, Parts shall be packaged to protect against damage during handling, transit and storage, per packaging specified on the engineering drawing.

## 7.0 GAGES AND FIXTURES

45624-0001 Footprint gage/mating side gage/ insertion depth gage for 45578-0001 header assembly  
 45738-0001 Footprint gage/mating side gage for 45608-0001 right angle header assembly.  
 46511-2000 Footprint gage/mating side gage for 46511-1000 1x6 header assembly.  
 45608-5000 Footprint gage/mating side gage for 45608-0012 2x6 right angle header assembly.

REVISION: <b>F</b>	ECR/ECN INFORMATION: EC No: <b>UCP2012-3935</b> DATE: <b>12/19/12</b>	TITLE: <b>PRODUCT SPECIFICATION SPOX BMI</b>	SHEET No. <b>6 of 5</b>
DOCUMENT NUMBER: <b>PS-45579-001</b>	CREATED / REVISED BY: <b>ROSCA</b>	CHECKED BY: <b>COMERCI</b>	APPROVED BY: <b>COMERCI</b>



# PRODUCT SPECIFICATION

## 8.0 TIE WRAP AND/OR WIRE TWISTING PLACEMENT

THE TERMINALS MUST FLOAT FREELY IN THE HOUSING.

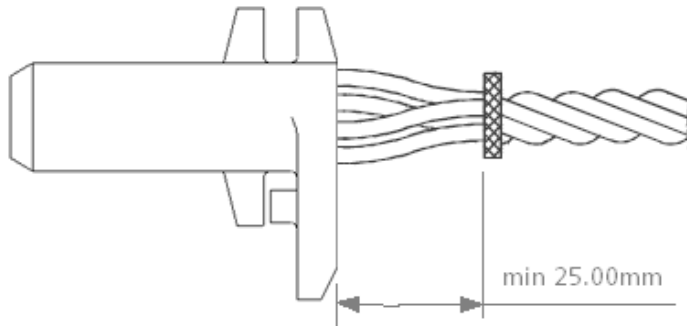

## 9.0 SOLDERABILITY

CONFORMS IPC-SM-782

SPOX BMI Solder Retention Results	
n = 16	Solder Retention Force, lbf
Minimum	31.50
Maximum	43.21
Average	39.13
Std. Dev.	4.24

IPC SOLDER JOINT REQUIREMENTS SURFACE MOUNT



REVISION: <b>F</b>	ECR/ECN INFORMATION: EC No: <b>UCP2012-3935</b> DATE: <b>12/19/12</b>	TITLE: <b>PRODUCT SPECIFICATION SPOX BMI</b>	SHEET No. <b>7 of 5</b>
DOCUMENT NUMBER: <b>PS-45579-001</b>	CREATED / REVISED BY: <b>ROSCA</b>	CHECKED BY: <b>COMERCI</b>	APPROVED BY: <b>COMERCI</b>