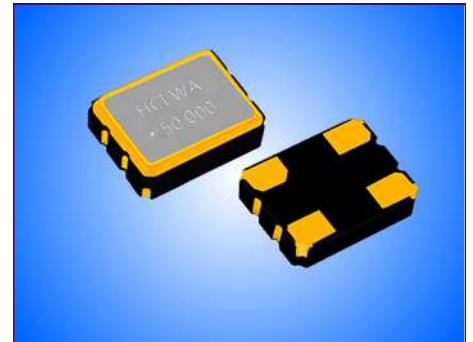

OSCILLATOR UNIT WITH CMOS OUTPUT IN SMD 3.2x2.5mm CERAMIC SEAM SEAL PACKAGE.
PRODUCT FEATURES

- Small dimensions 3.2x2.5x1.0 with 4 solder pads.
- Tight stabilities over temperature range.
- Tri-state enable/ disable function (pad 1).
- Automotive compliance to AEC-Q200 available.
- ROHS compliant, LEAD-FREE, HALOGEN-FREE and REACH compliant.

APPLICATIONS

- WiFi / WiMAX / Bluetooth
- Mobil phone
- Set-top Box / HDTV

PRODUCT PHOTO (NOT IN SCALE)

PRODUCT SPECIFICATIONS

PARAMETER	SUPPLY VOLTAGE			REMARKS
	1.8V	2.5V	3.3V	
Frequency range	1.25 ~ 125MHz	1.25 ~ 125MHz	1.25 ~ 125MHz	32.768kHz available
Frequency stability	±20ppm / ±25ppm / ±50ppm			See note below
Operating temperature range	-10 to +60°C / -20 to +70°C / -40 to +85°C			options available
Aging first year	±3.0ppm			@+25°C
Supply current	7mA	10mA	15mA	with load 15pF
Output waveform and load	LVCMOS 15pF			30pF optional
Output voltage level HIGH	1.62V	2.25V	2.97V	Minimum
Output voltage level LOW	0.18V	0.25V	0.33V	Maximum
Rise and Fall times	5ns	4ns	3ns	<10MHz @10~90% of V _{CC}
	4ns	3ns	3ns	≥10MHz @10~90% of V _{CC}
Symmetry (duty cycle)	45~55% or 40~60%			@ 50%V _{CC}
Phase jitter RMS	<1ps			12kHz≤F _j ≤20MHz

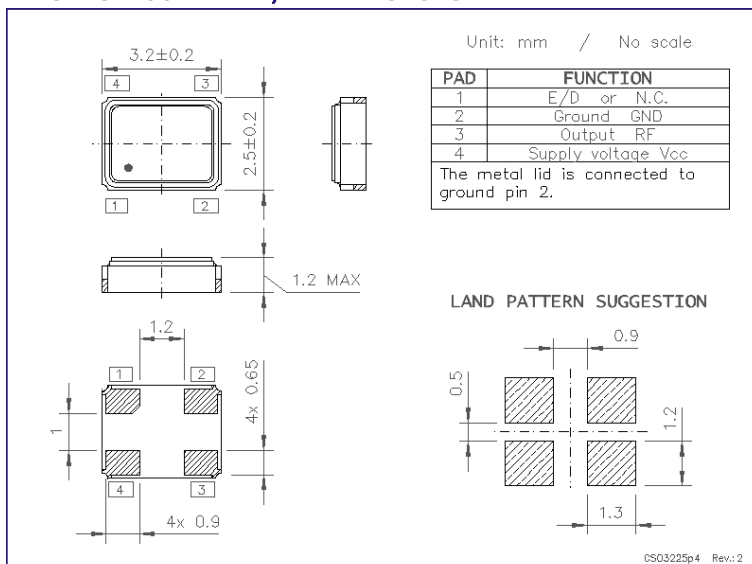
Note: Stability includes frequency deviations at +25°C, over temperature range, due to supply voltage changes, output load changes, shock and vibration.

PACKAGE OUTLINE / DIMENSIONS

PACKAGING INFORMATION

- Tape & Reel compliant to EIA-481.
- Embossed carrier width 8mm.
- Component pitch in carrier 4mm.
- Reel diameter 180mm.
- QTY per reel: 3,000pcs

RECOMMENDED REFLOW PROFILE
