

FEATURES

- Automatic gain control
- DC Restorer for immunity to SDI pathological bit patterns
- Supports SDI data rates from 143Mb/s to 1.485Gb/s
- Signal strength indicator
- Internal 50 ohm output termination resistors
- Minimal external components
- Seamless output interface to other HD-LINX devices
- Single +5V or -5V power supply

APPLICATIONS

- SMPTE 292M Fibre-Optic Serial Digital Interfaces

DESCRIPTION

The GS1514 is an AGC & DC Restorer circuit to be used in conjunction with an optical receiver. It will automatically amplify input signals in addition to restoring DC content to signals which have been AC coupled. This device also incorporates a signal strength indicator signal which is an indication of the received input swing (which equates to the received optical power). When the lower input limit is reached, the output is muted (latched to the last state) and the situation is indicated by the MUTE pin. This mute condition can be overridden and the output can be forced to either an active or a mute situation.

ORDERING INFORMATION

PART NUMBER	PACKAGE	TEMPERATURE
GS1514-CKD	16 pin narrow SOIC	0°C to 70°C
GS1514-CTD	16 pin Tape and Reel	0°C to 70°C

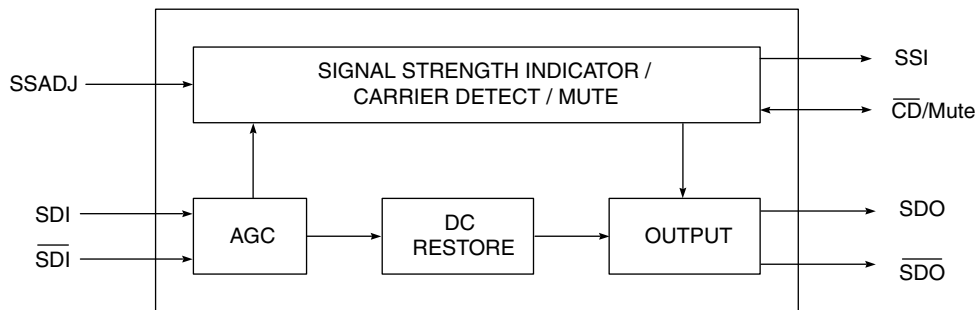

GS1514 FUNCTIONAL BLOCK DIAGRAM

ABSOLUTE MAXIMUM RATINGS

PARAMETER	VALUE
Supply Voltage	0.5V _{DC} to +5.5 V _{DC}
Input ESD Voltage	TBD
Storage Temperature Range	-50°C < T _s < 125°C
Lead Temperature (soldering 10 seconds)	260°C

DC ELECTRICAL CHARACTERISTICSV_{DD} = 5V, T_A = 0°C to 70°C, unless otherwise shown

PARAMETER	CONDITIONS	MIN	TYP	MAX	UNITS	NOTES
Positive Supply Voltage	-	+4.75	+5.00	+5.25	V	
Power Consumption	-	-	260	-	mW	
Supply Current	-	-	52	-	mA	
Input DC Voltage	-	-	2.7	-	V	
Output CM Voltage	-	-	4	-	V	
SSI DC Voltage	Max Input Swing	-	3.5	-	V	
	Min Input Swing	-	1.5	-	V	
Mute DC Voltage	Below Min Input Swing	-	1.8	-	V	

AC ELECTRICAL CHARACTERISTICSV_{DD} = 5V, T_A = 0°C to 70°C, unless otherwise shown

PARAMETER	CONDITIONS	MIN	TYP	MAX	UNITS	NOTES
Jitter	1.5Gb/s, 800mV input, Pathological & PRN		150	-	ps	p-p
	1.5Gb/s, 20mV input, Pathological & PRN		250	-	ps	p-p
Data Rate	-	143	-	1485	Mb/s	
Output Rise/Fall Time	-	-	-	270	ps	20% to 80%
Input Resistance	-	-	2.8	-	kΩ	Single-ended
Output Resistance	-	-	50	-	Ω	Single-ended
Output Signal Swing	50Ω Loads	-	0.4	-	V	p-p (same as GS1504)
SSI Range	-	-	2	-	V	Ranges ~ 3.5V to 1.5V, max. to min. input swing
Force Output Mute	Applied to Mute	-	4.2	-	V	Min. to Mute

PIN DESCRIPTIONS

PIN	NAME	LEVEL	I/O	DESCRIPTION
1	SSI	Analog	Output	Signal Strength Indicator. Provides a linear voltage representation of the received signal swing.
2,15	V _{cc}		Input	Most positive supply voltage
3, 6,11,14	V _{ee}		Input	Most negative supply voltage.
4,5	SDI, $\overline{\text{SDI}}$	Analog	Input	Serial Data Input. Differential input pins. Output of optical receive module should be AC coupled to these pins.
7	SSADJ	Analog	Input	Signal Strength Adjust. Adjusts the minimum input signal strength which be restored. To set no minimum limit, this pin should be left open.
8, 9,10	NC			No Connect. Do not connect these pins to supply or ground
12,13	SDO, $\overline{\text{SDO}}$	PECL	Output	Serial Data Output. Differential serial output pins with 50 Ω output impedance.
16	$\overline{\text{CD}}$ /Mute		Output/Input	Carrier Detect/Mute indicator/control. When the CD/Mute output is low, the carrier is present and the data output is active. When the CD/Mute output is high, the carrier is not present and the data output is muted (latched to the last state). This indicates that the minimum input signal as set by SSADJ has been reached. The above default $\overline{\text{CD}}$ /Mute function can be overwritten as follows: if the CD/Mute pin is tied to ground, the data output will not mute and the SSADJ setting is overwritten. If the mute pin is tied high, the data output will always mute and the SSADJ setting is overwritten

PACKAGE DIMENSIONS

Dimensions in millimeters

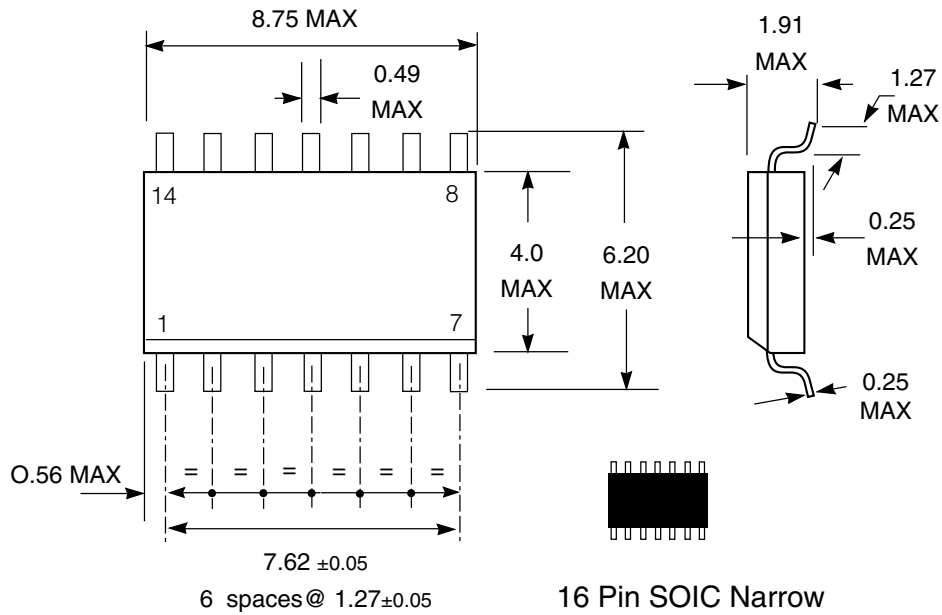

GS1514

CAUTION
 ELECTROSTATIC SENSITIVE DEVICES
 DO NOT OPEN PACKAGES OR HANDLE EXCEPT AT A STATIC-FREE WORKSTATION



DOCUMENT IDENTIFICATION
 ADVANCE INFORMATION NOTE
 The product is in a development phase and specifications are subject to change without notice. Gennum reserves the right to remove the product at any time. Listing the product does not constitute an offer for sale.

REVISION NOTES:
 Update to AC and DC tables.
 Watermark Removed

GENNUM CORPORATION

MAILING ADDRESS:
 P.O. Box 489, Stn. A, Burlington, Ontario, Canada L7R 3Y3
 Tel. +1 (905) 632-2996 Fax. +1 (905) 632-5946

SHIPPING ADDRESS:
 970 Fraser Drive, Burlington, Ontario, Canada L7L 5P5

GENNUM JAPAN CORPORATION
 C-101, Miyamae Village, 2-10-42 Miyamae, Suginami-ku
 Tokyo 168-0081, Japan
 Tel. +81 (03) 3334-7700 Fax. +81 (03) 3247-8839

GENNUM UK LIMITED
 25 Long Garden Walk, Farnham, Surrey, England GU9 7HX
 Tel. +44 (0)1252 747 000 Fax +44 (0)1252 726 523

Gennum Corporation assumes no responsibility for the use of any circuits described herein and makes no representations that they are free from patent infringement.
 © Copyright February 2001 Gennum Corporation. All rights reserved. Printed in Canada.