

Specifications:  
 Current rating:1.0A AC,DC  
 Voltage rating:50V AC, DC  
 Contact tesistance:20m ohm Max  
 Insulation resistance:1,000M ohm Min  
 Withstanding voltage:500V AC/minute  
 Operating Temperature:-40°C ~ +105°C

Materials:  
 Insulator:Nylon 9T(UL94V-0)  
 Standard Color:Black  
 Terminal:Brass  
 Finish:Gold Plated

MATING PART  
 3230-XX-0101-00

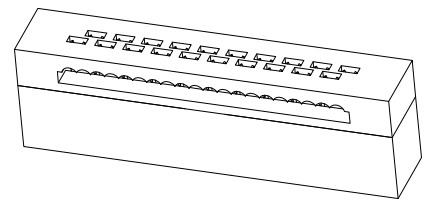

MATING PART  
 3230-XX-0102-00

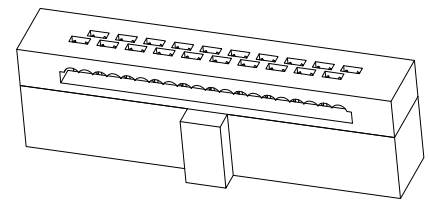

Dimension Information:

Pin.No	Dim.A	Dim.B	Dim.C	Pin.No	Dim.A	Dim.B	Dim.C
8	3.81	9.83	11.43	26	15.24	21.26	22.86
10	5.08	11.10	12.70	30	17.78	23.80	25.40
12	6.35	12.37	13.97	34	20.32	26.34	27.94
14	7.62	13.64	15.24	40	24.13	30.15	31.75
16	8.89	14.91	16.51	44	26.67	32.69	34.29
20	11.43	17.45	19.05	50	30.48	36.50	38.10
24	13.97	19.99	21.59	60	36.83	42.85	44.45

RoHS Compliant

				DRAWN: Jamie	GENERAL TOLERANCE: .X=±0.25 .XX=±0.20	<h1 style="color: red; text-align: center;">CnC Tech</h1> <p style="text-align: center;">Industrial Cable and Connector Technology</p>	
D	10-Apr-2023			CHECKED: Jerry	UNIT: MM		
C	01-Mar-2020			APPROVAL: Rory	SCALE:1:1	PART NO: 3220-XX-0300-00	A4
B	16-Jul-2019				SHEET: 1 / 2		
A	19-Dec-2018			PROJECTION:			
REV	DATE	FILE	BY				

1

2

3

4

5

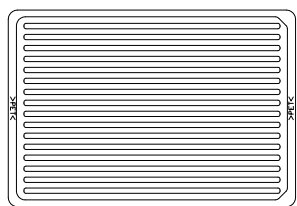

Bottom Tray



Bottom Tray

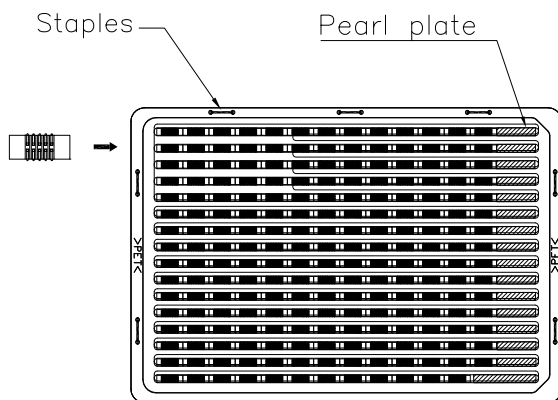

Tray layout

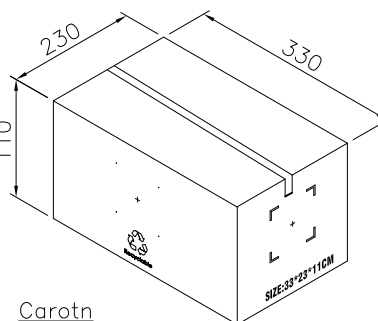
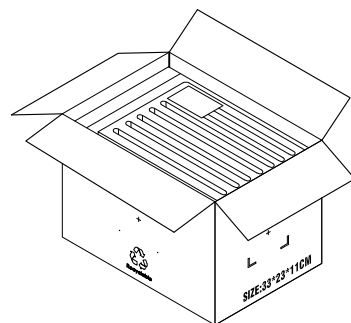
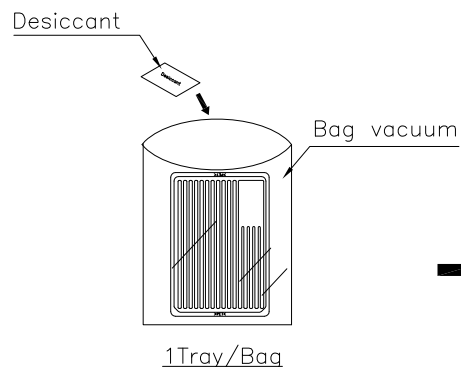

Carotn

Note:

1.Dimension:

Tray Size: 314(L)x218(W)x8.7(H) (mm)  
 294(L)x218(W)x8.7(H) (mm) (Only 10Pin)  
 Carotn Size: 330(L)x230(W)x110(H) (mm)

2.Quantity:

10 Trays/Carton

3.CNC Tech recommends the following storage conditions for our SMD products in full factory packaging:

- (a) +18°C ~+28°C for temperature; relative humidity 30%~70%.
- (b) If stored in factory packaging in these conditions, we can guarantee the product to be free of moisture issues for up to a period of 1 year after delivery.
- (c) After one year, we recommend that the product be reinspected and baked if necessary.

We recommend that all of our SMD products be used in the reflow soldering process within 24 hours after opening factory packaging. If the product is not used up within 24 hours after opening, we recommend the parts be inspected and baked if necessary. Below are our recommendations for baking.

## Product storage time and baking table

Product Material	Packing	Store Time	Baking Method
Nylon 9T	Tray	3 months	40°C 12Hrs (with tray)
	Reel	1 year	55°C 8Hrs (with tape & reel)
	Product can be baked directly		120°C 2Hrs

Quantity:

Pin No.	Pcs/Tray	Q'TY
10	320	3200
14	260	2600
16	240	2400
20	220	2200
26	180	1800
40	120	1200
50	110	1100
60	90	900

RoHS Compliant

REV	DATE	FILE	BY	DRAWN:	GENERAL TOLERANCE:	CnC Tech Industrial Cable and Connector Technology		SIZE
				Jamie	.X=±0.25 .XX=±0.20	DESCRIPTION: 1.27mm Box Header SMD Type		A4
D	10-Apr-2023			CHECKED:	UNIT: MM			
C	01-Mar-2020			Jerry	SCALE:	PART NO: 3220-XX-0300-00		D
B	16-Jul-2019			APPROVAL:	SHEET: 2 / 2			
A	19-Dec-2018			Rory	PROJECTION:			