

282080-2 ✓ ACTIVE

AMP | AMP Superseal 1.5mm Series

TE Internal #: 282080-2

Housing for Female Terminals, Wire-to-Wire / Wire-to-Board / Wire-to-Device, 2 Position, .236 in [6 mm] Centerline, AMP Superseal 1.5 mm Series

[View on TE.com >](#)



Connectors > Automotive Connectors > Automotive Housings > AMP SUPERSEAL 1.5MM, CONNECTOR HOUSING

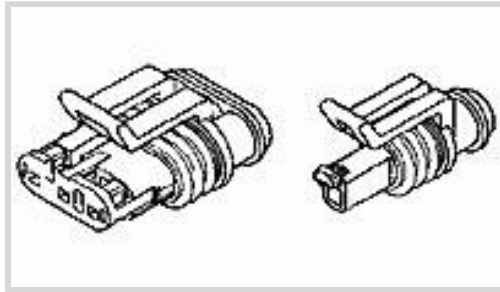

Connector & Housing Type: **Housing for Female Terminals**

Mating Tab Width: **1.5 mm [ .059 in ]**

Connector System: **Wire-to-Board, Wire-to-Device, Wire-to-Wire**

Number of Positions: **2**

Centerline (Pitch): **6 mm [ .236 in ]**

[All AMP SUPERSEAL 1.5MM, CONNECTOR HOUSING \(27\)](#)

## Features

### Product Type Features

Connector Shape	Rectangular
Connector & Housing Type	Housing for Female Terminals
Connector System	Wire-to-Board, Wire-to-Device, Wire-to-Wire
Sealable	Yes
Hybrid Connector	No
Primary Locking Feature	Integrated in Housing
Connector & Contact Terminates To	Wire & Cable

### Configuration Features

Number of Positions	2
Number of Rows	1

### Electrical Characteristics

Operating Voltage	24 VDC
Nominal Voltage Architecture	12 V, 24 V

### Body Features

Cable Exit Angle	180°
Primary Product Color	Gray



Connector & Keying Code	Neutral
-------------------------	---------

### Contact Features

Contact Size	1.5mm
Contact Type	Receptacle
Mating Tab Width	1.5 mm[.059 in]
Contact Current Rating (Max)	14 A

### Mechanical Attachment

Terminal Position Assurance	Yes
Strain Relief	Without
Mating Alignment Type	Polarizing Rib
Mating Alignment	With
Connector Mounting Type	Cable Mount (Free-Hanging)

### Housing Features

Housing Material	PA GF
Centerline (Pitch)	6 mm[.236 in]

### Dimensions

Connector Height	32.2 mm[1.268 in]
Product Width	9.3 mm[.366 in]
Product Length	17.1 mm[.673 in]

### Usage Conditions

Operating Temperature (Max)	70 °C, 75 °C, 80 °C, 85 °C, 90 °C, 100 °C, 105 °C, 110 °C, 120 °C, 125 °C[158 °F][167 ° F][176 °F][185 °F][194 °F][212 °F][221 °F][230 °F][248 °F][257 °F]
Operating Temperature Range	-40 – 125 °C[-40 – 257 °F]

### Operation/Application

Circuit Application	Signal
---------------------	--------

### Industry Standards

Degree of Protection	IP67
----------------------	------

### Packaging Features

Packaging Quantity	800
Packaging Method	Bag

### Other



Serviceable	Yes
Connector Position Assurance Capable	No

### Product Compliance

[For compliance documentation, visit the product page on TE.com>](#)

EU RoHS Directive 2011/65/EU	Compliant
EU ELV Directive 2000/53/EC	Compliant
China RoHS 2 Directive MIIT Order No 32, 2016	No Restricted Materials Above Threshold
EU REACH Regulation (EC) No. 1907/2006	Current ECHA Candidate List: JUNE 2023 (235) Candidate List Declared Against: JAN 2023 (233) Does not contain REACH SVHC
Halogen Content	BFR/CFR/PVC Free, but Br/Cl >900 ppm in other sources.
Solder Process Capability	Not applicable for solder process capability

#### Product Compliance Disclaimer

This information is provided based on reasonable inquiry of our suppliers and represents our current actual knowledge based on the information they provided. This information is subject to change. The part numbers that TE has identified as EU RoHS compliant have a maximum concentration of 0.1% by weight in homogenous materials for lead, hexavalent chromium, mercury, PBB, PBDE, DBP, BBP, DEHP, DIBP, and 0.01% for cadmium, or qualify for an exemption to these limits as defined in the Annexes of Directive 2011/65/EU (RoHS2). Finished electrical and electronic equipment products will be CE marked as required by Directive 2011/65/EU. Components may not be CE marked. Additionally, the part numbers that TE has identified as EU ELV compliant have a maximum concentration of 0.1% by weight in homogenous materials for lead, hexavalent chromium, and mercury, and 0.01% for cadmium, or qualify for an exemption to these limits as defined in the Annexes of Directive 2000/53/EC (ELV). Regarding the REACH Regulation, the information TE provides on SVHC in articles for this part number is based on the latest European Chemicals Agency (ECHA) 'Guidance on requirements for substances in articles' posted at this URL: <https://echa.europa.eu/guidance-documents/guidance-on-reach>

### Compatible Parts

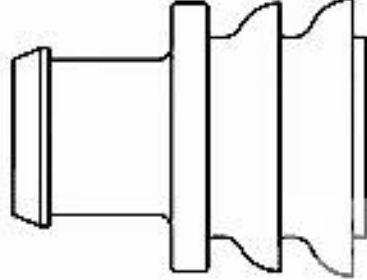
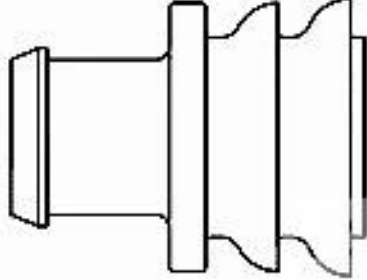
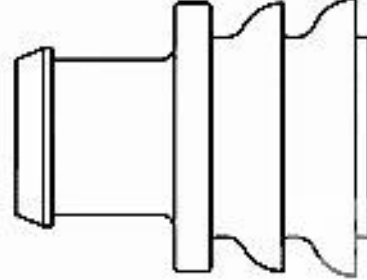
 <p>TE Part # 9-1579007-1 EXTRACTION TOOL</p>	 <p>TE Part # 281934-3 SINGLE WIRE SEAL</p>	 <p>TE Part # 282081-1 RUBBER PLUG</p>	 <p>TE Part # 281934-2 SINGLE WIRE SEAL</p>
--	--	---	--

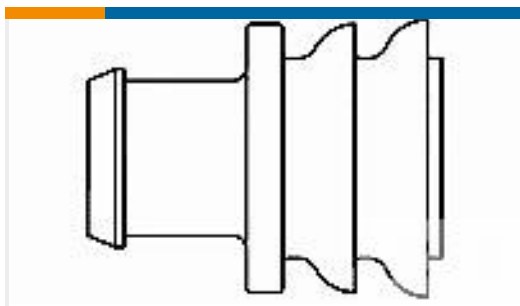

TE Part # 281934-4  
SINGLE WIRE SEAL



TE Part # CAT-AM71-CH8172  
AMP SUPERSEAL 1.5MM,  
CONNECTOR HOUSING



TE Part # CAT-AM71-T273  
AMP SUPERSEAL 1.5MM,  
RECEPTACLE AND TAB



TE Part # 2325593-2  
REC CONN CVR,2POS,MINI MIC

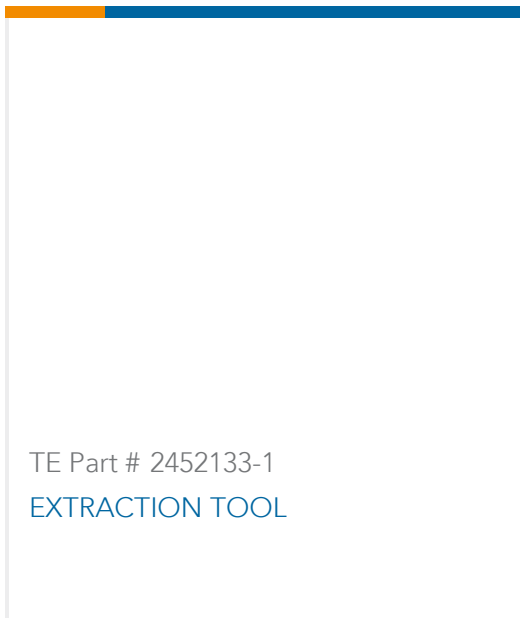

TE Part # 2452133-1  
EXTRACTION TOOL

### Also in the Series | AMP Superseal 1.5mm Series



Automotive Connector Caps & Covers  
(2)



Automotive Housings(29)



Automotive Seals & Cavity Plugs(4)



Automotive Terminals(17)



Insertion & Extraction Tools(3)



Other Automotive Connector  
Accessories(2)

### Customers Also Bought



TE Part #1456471-2  
8p Hybrid 0.64/2.8 Unsealed Plug Assy

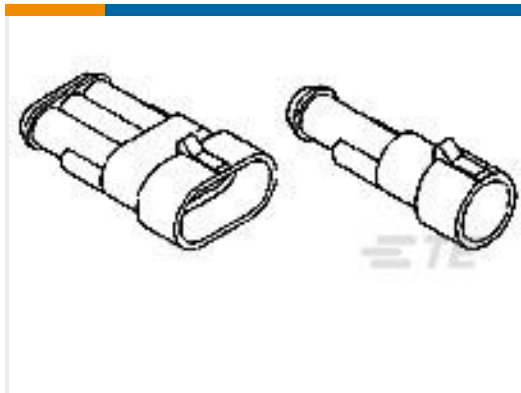

TE Part #282104-3  
AMP SUPERSEAL 1.5 SERIES 2P CA



TE Part #4-2112594-1  
MQS, CONNECTOR HOUSING

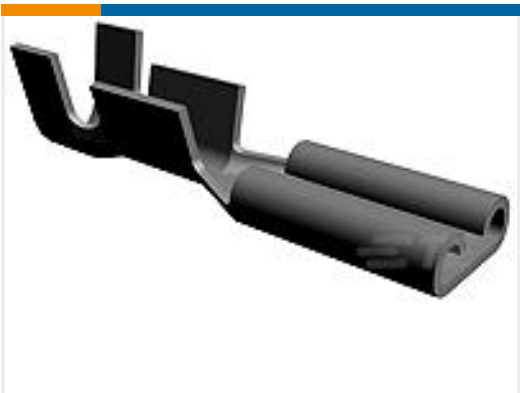

TE Part #60252-1  
103 FASTON REC 22-18 AWG TPBR



TE Part #170303-1  
FF 250 REC 22-18AWG BR WITH  
LATCH



TE Part #1-1801178-1  
3W RECEPTACLE HP CONNECTOR  
BLACK



TE Part #1-444314-1  
HSG ASSY 9P COMBINED



TE Part #2203770-2  
2POS, MCON 1.2 CB TAB 1p TL  
SEALED

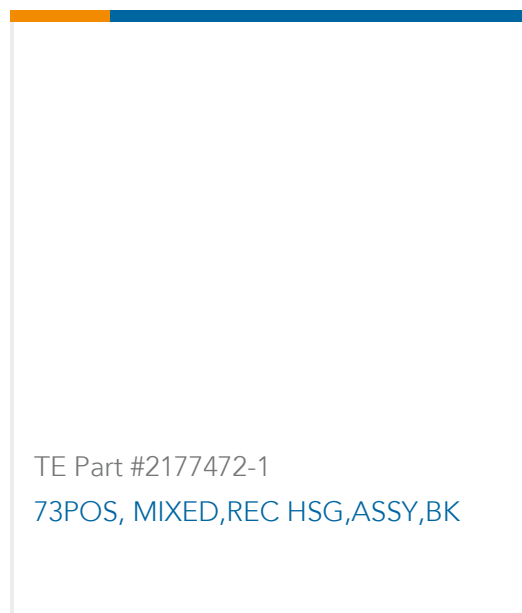

TE Part #2177472-1  
73POS, MIXED, REC HSG, ASSY, BK

## Documents

### Product Drawings

[AMP SUPERSEAL 1.5 SERIES 2P PL](#)

English

### CAD Files

[3D PDF](#)

3D

**Customer View Model**

[ENG\\_CVM\\_CVM\\_282080-2\\_D.2d\\_dxf.zip](#)

English

**Customer View Model**

[ENG\\_CVM\\_CVM\\_282080-2\\_D.3d\\_igs.zip](#)

English

**Customer View Model**

[ENG\\_CVM\\_CVM\\_282080-2\\_D.3d\\_stp.zip](#)

English

By downloading the CAD file I accept and agree to the [Terms and Conditions](#) of use.

### Datasheets & Catalog Pages

[AMP SUPERSEAL 1.5mm Connector System](#)

English

[ICT Terminals and Connectors Catalogue](#)

English

### Product Specifications

[Product Specification](#)

English





**Instruction Sheets**

**AMP SUPERSEAL 1.5 SERIES**

English

**Customer Manual (non U.S.)**

English