

PART #	WIRE O.D. RANGE	WIRE Ga.	"D1"	"D2"	"L1" ±.04 (±1.0)	"L" ±.04 (±1.0)
224222	.058-.080	24-20	.09 (2.2)	.18 (4.5)	.28 (7.0)	.55 (14.0)
224225	.058-.091	22-18	.10 (2.5)	.16 (4.0)	.24 (6.0)	.51 (13.0)
224228	.058-.091	22-18	.11 (2.8)	.18 (4.5)	.28 (7.0)	.51 (13.0)
224230	.068-.113	20-18	.12 (3.0)	.16 (4.0)	.24 (6.0)	.51 (13.0)
224232	.071-.126	18-16	.13 (3.2)	.18 (4.5)	.28 (7.0)	.55 (14.0)
224235	.071-.140	18-14	.14 (3.5)		.24 (6.0)	.51 (13.0)
224240	.091-.140	16-14	.16 (4.0)			

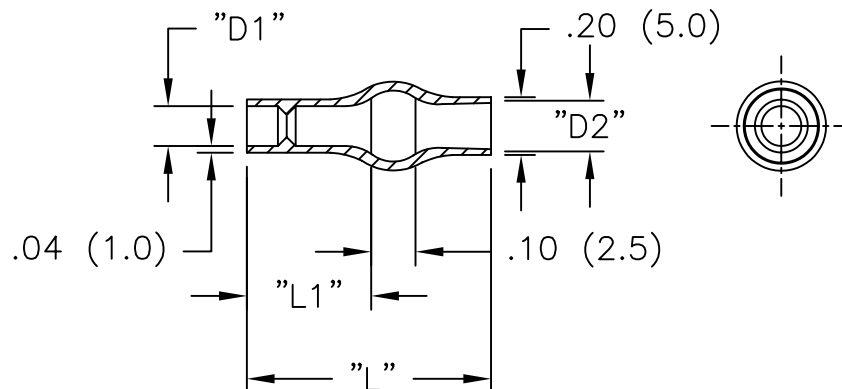

NOTES:

1. MATERIAL: SOFT PVC (RMS-55).
2. COLOR: TRANSPARENT BLUE.

REV	DESCRIPTION	ENGR	DATE
A	CHANGED FILE NO. AND TITLE BLOCK	SM	03.21.02

TITLE: INSULATING SLEEVE FOR PIN PLUG				DWG IN IN (MM)	FINAL	PRINT TYPE
TOLERANCES UNLESS NOTED .XX=±.010 .XXX=±.005 FRAC=±1/64 ANG=±1'	FILE # 2242XX	DWN: D.D	APP:	PART # SEE TABLE	CA	
MAT'L: SEE NOTES	RE: RICHCO, INC.	DT: 05-21-96	DT:			
RICHCO INC. PO BOX 804238, CHICAGO, 60680 (773) 539-4060						