

LPC 16 HC/ 5-ST-10,16 - PCB connector



1716818

<https://www.phoenixcontact.com/pc/products/1716818>

Please be informed that the data shown in this PDF document is generated from our online catalog. Please find the complete data in the user documentation. Our general terms of use for downloads are valid.



PCB connector, nominal cross section: 16 mm², color: green, nominal current: 76 A, rated voltage (III/2): 1000 V, contact surface: Tin, contact connection type: Socket, number of rows: 1, number of positions: 5, product range: LPC 16 HC/...-ST, pitch: 10.16 mm, connection method: Lever Push-in connection, conductor/PCB connection direction: 0 °, locking clip: - without locking clip, plug-in system: COMBICON PC 16 advanced, locking: without, mounting: without, type of packaging: packed in cardboard

Your advantages

- Tool-free lever principle enables time-saving connection and release of conductors with/without ferrules
- Clear lever positions provide reliable feedback on opened or closed clamping spaces
- Defined contact force ensures that contact remains stable over the long term
- Time-saving push-in connection when lever is closed
- Increased touch protection in accordance with IEC/UL 61800-5-1

Commercial data

Item number	1716818
Packing unit	25 pc
Minimum order quantity	25 pc
Product key	AAEBAA
GTIN	4055626689883
Weight per piece (including packing)	98.64 g
Weight per piece (excluding packing)	98.64 g
Customs tariff number	85366990
Country of origin	PL

LPC 16 HC/ 5-ST-10,16 - PCB connector



1716818

<https://www.phoenixcontact.com/pc/products/1716818>

Technical data

Product properties

Product line	COMBICON Connectors XL
Product type	PCB connector
Product family	LPC 16 HC/..-ST
Number of positions	5
Pitch	10.16 mm
Number of rows	1
Mounting flange	without

Electrical properties

Nominal current I_N	76 A
Nominal voltage U_N	1000 V
Degree of pollution	3
Contact resistance	0.235 m Ω
Rated voltage (III/3)	1000 V
Rated surge voltage (III/3)	8 kV
Rated voltage (III/2)	1000 V
Rated surge voltage (III/2)	8 kV
Rated voltage (II/2)	1000 V
Rated surge voltage (II/2)	6 kV

Connection data

Connection technology

Connector system	COMBICON PC 16 advanced
Nominal cross section	16 mm ²
Contact connection type	Socket

Interlock

Locking type	without
Mounting flange	without

Conductor connection

Connection method	Lever Push-in connection
Conductor/PCB connection direction	0 °
Conductor cross section rigid	0.75 mm ² ... 16 mm ²
Conductor cross section flexible	0.75 mm ² ... 16 mm ²
Conductor cross section AWG	18 ... 4
Conductor cross section flexible, with ferrule without plastic sleeve	0.75 mm ² ... 16 mm ²
Conductor cross section, flexible, with ferrule, with plastic sleeve	0.75 mm ² ... 16 mm ²
Cylindrical gauge a x b / diameter	- / 5.4 mm
Stripping length	18 mm

LPC 16 HC/ 5-ST-10,16 - PCB connector

1716818

<https://www.phoenixcontact.com/pc/products/1716818>

Material specifications

Material data - contact

Note	WEEE/RoHS-compliant, free of whiskers according to IEC 60068-2-82/JEDEC JESD 201
Contact material	Cu alloy
Surface characteristics	hot-dip tin-plated
Metal surface terminal point (top layer)	Tin (10 - 16 μm Sn)
Metal surface contact area (top layer)	Tin (10 - 16 μm Sn)

Material data - housing

Color (Housing)	green (6021)
Insulating material	PA
Insulating material group	I
CTI according to IEC 60112	600
Flammability rating according to UL 94	V0

Material data – actuating element

Color (Actuating element)	orange (2003)
Insulating material	PA GF
Insulating material group	I
CTI according to IEC 60112	600
Flammability rating according to UL 94	V0

Dimensions

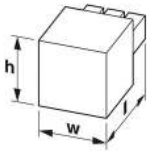
Dimensional drawing	
Pitch	10.16 mm
Width [w]	54 mm
Height [h]	32.2 mm
Length [l]	56.3 mm

Notes

Notes on operation	In accordance with IEC 61984, COMBICON connectors have no switching power (COC). During designated use, they must not be plugged in or disconnected when carrying voltage or under load.
--------------------	--

Mechanical tests

Conductor connection

Specification	IEC 60999-1:1999-11
Result	Test passed

LPC 16 HC/ 5-ST-10,16 - PCB connector



1716818

<https://www.phoenixcontact.com/pc/products/1716818>

Test for conductor damage and slackening

Specification	IEC 60999-1:1999-11
Result	Test passed

Repeated connection and disconnection

Specification	IEC 60999-1:1999-11
Result	Test passed

Pull-out test

Specification	IEC 60999-1:1999-11
Conductor cross section/conductor type/tractive force setpoint/actual value	0.75 mm ² / solid / > 30 N
	0.75 mm ² / flexible / > 30 N
	16 mm ² / solid / > 100 N
	16 mm ² / flexible / > 100 N

Insertion and withdrawal forces

Result	Test passed
No. of cycles	25
Insertion strength per pos. approx.	8 N
Withdraw strength per pos. approx.	6 N

Resistance of inscriptions

Specification	IEC 60068-2-70:1995-12
Result	Test passed

Polarization and coding

Specification	IEC 60512-13-5:2006-02
Result	Test passed

Visual inspection

Specification	IEC 60512-1-1:2002-02
Result	Test passed

Dimension check

Specification	IEC 60512-1-2:2002-02
Result	Test passed

Environmental and real-life conditions

Vibration test

Specification	IEC 60068-2-6:2007-12
Frequency	10 - 150 - 10 Hz
Sweep speed	1 octave/min
Amplitude	0.15 mm (10 Hz ... 60.1 Hz)
Sweep speed	20 m/s ² (60.1 Hz ... 150 Hz)
Test duration per axis	2.5 h

Durability test

LPC 16 HC/ 5-ST-10,16 - PCB connector



1716818

<https://www.phoenixcontact.com/pc/products/1716818>

Specification	IEC 60512-9-1:2010-03
Impulse withstand voltage at sea level	9.8 kV
Contact resistance R ₁	0.235 mΩ
Contact resistance R ₂	0.212 mΩ
Insertion/withdrawal cycles	25
Insulation resistance, neighboring positions	> 5 MΩ

Climatic test

Specification	ISO 6988:1985-02
Corrosive stress	0.2 dm ³ SO ₂ on 300 dm ³ /40 °C/1 cycle
Thermal stress	105 °C/168 h
Power-frequency withstand voltage	4.26 kV

Ambient conditions

Ambient temperature (operation)	-40 °C ... 105 °C (dependent on the derating curve)
Ambient temperature (storage/transport)	-40 °C ... 70 °C
Relative humidity (storage/transport)	30 % ... 70 %
Ambient temperature (assembly)	-5 °C ... 100 °C

Electrical tests

Thermal test | Test group C

Specification	IEC 60512-5-1:2002-02
Tested number of positions	6

Insulation resistance

Specification	IEC 60512-3-1:2002-02
Insulation resistance, neighboring positions	> 5 MΩ

Temperature cycles

Specification	IEC 60999-1:1999-11
Result	Test passed

Air clearances and creepage distances | 1. Insulation coordination

Specification	IEC 61984:2008-10
Insulating material group	I
Comparative tracking index (IEC 60112)	CTI 600
Rated insulation voltage (III/3)	1000 V
Rated surge voltage (III/3)	8 kV
minimum clearance value - non-homogenous field (III/3)	8 mm
minimum creepage distance (III/3)	12.5 mm
Rated insulation voltage (III/2)	1000 V
Rated surge voltage (III/2)	8 kV
minimum clearance value - non-homogenous field (III/2)	8 mm
minimum creepage distance (III/2)	8 mm
Rated insulation voltage (II/2)	1000 V
Rated surge voltage (II/2)	6 kV

LPC 16 HC/ 5-ST-10,16 - PCB connector



1716818

<https://www.phoenixcontact.com/pc/products/1716818>

minimum clearance value - non-homogenous field (II/2)	5.5 mm
minimum creepage distance (II/2)	5.5 mm

Air clearances and creepage distances | 2. Insulation coordination

Specification	IEC 60664-1:2020-05
Insulating material group	I
Comparative tracking index (IEC 60112)	CTI 600
Rated insulation voltage (III/3)	1000 V AC/DC
Rated surge voltage (III/3)	8 kV
minimum clearance value - non-homogenous field (III/3)	8 mm
minimum creepage distance (III/3)	12.5 mm
Rated insulation voltage (III/2)	1500 V DC
Rated surge voltage (III/2)	10 kV
minimum clearance value - non-homogenous field (III/2)	11 mm
minimum creepage distance (III/2)	11 mm
Rated insulation voltage (II/2)	1500 V DC
Rated surge voltage (II/2)	8 kV
minimum clearance value - non-homogenous field (II/2)	8 mm
minimum creepage distance (II/2)	8 mm

Packaging specifications

Type of packaging	packed in cardboard
-------------------	---------------------

Drawings

Diagram

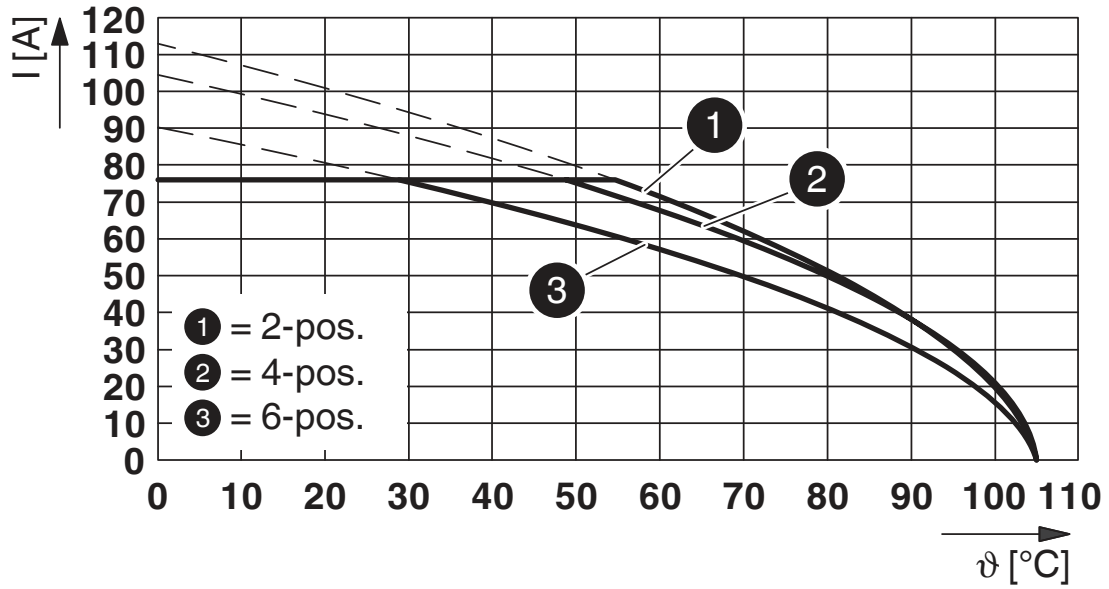

Type: LPC 16 HC/...-ST(L...)-10,16 with PC 16 HC/...-G(L...)-10,16

LPC 16 HC/ 5-ST-10,16 - PCB connector



1716818

<https://www.phoenixcontact.com/pc/products/1716818>

Classifications

ECLASS

ECLASS-11.0	27460202
ECLASS-12.0	27460202
ECLASS-13.0	27460202

ETIM

ETIM 8.0	EC002638
----------	----------

UNSPSC

UNSPSC 21.0	39121400
-------------	----------

LPC 16 HC/ 5-ST-10,16 - PCB connector

1716818

<https://www.phoenixcontact.com/pc/products/1716818>

Accessories

CP-PC RD - Coding profile

1701967

<https://www.phoenixcontact.com/pc/products/1701967>

Coding profile, for plugging into the coding ribs of the plug at a later date, insulating material, color: Red



PC 16 HC/ 5-G-10,16 - PCB header

1716850

<https://www.phoenixcontact.com/pc/products/1716850>

PCB headers, nominal cross section: 16 mm², color: green, nominal current: 76 A, rated voltage (III/2): 1000 V, contact surface: Tin, contact connection type: Pin, number of rows: 1, number of positions: 5, product range: PC 16 HC/..-G, pitch: 10.16 mm, mounting: Wave soldering, pin layout: Linear pinning, solder pin [P]: 4 mm, number of solder pins per potential: 4, plug-in system: COMBICON PC 16 advanced, Pin connector pattern alignment: Standard, locking: without, mounting: without, type of packaging: packed in cardboard



Phoenix Contact 2023 © - all rights reserved

<https://www.phoenixcontact.com>

PHOENIX CONTACT GmbH & Co. KG

Flachsmarktstraße 8

D-32825 Blomberg

+49 (0) 5235-3 00

info@phoenixcontact.com