

ON Semiconductor

Is Now

The logo for onsemi, featuring the word "onsemi" in a dark teal, lowercase, sans-serif font. The letter "i" is stylized with a white dot and a teal vertical bar. A small orange triangle is positioned above the top right of the "i". A trademark symbol (TM) is located to the right of the logo.

To learn more about onsemi™, please visit our website at
www.onsemi.com

onsemi and **onsemi** and other names, marks, and brands are registered and/or common law trademarks of Semiconductor Components Industries, LLC dba "**onsemi**" or its affiliates and/or subsidiaries in the United States and/or other countries. **onsemi** owns the rights to a number of patents, trademarks, copyrights, trade secrets, and other intellectual property. A listing of **onsemi** product/patent coverage may be accessed at www.onsemi.com/site/pdf/Patent-Marking.pdf. **onsemi** reserves the right to make changes at any time to any products or information herein, without notice. The information herein is provided "as-is" and **onsemi** makes no warranty, representation or guarantee regarding the accuracy of the information, product features, availability, functionality, or suitability of its products for any particular purpose, nor does **onsemi** assume any liability arising out of the application or use of any product or circuit, and specifically disclaims any and all liability, including without limitation special, consequential or incidental damages. Buyer is responsible for its products and applications using **onsemi** products, including compliance with all laws, regulations and safety requirements or standards, regardless of any support or applications information provided by **onsemi**. "Typical" parameters which may be provided in **onsemi** data sheets and/or specifications can and do vary in different applications and actual performance may vary over time. All operating parameters, including "Typicals" must be validated for each customer application by customer's technical experts. **onsemi** does not convey any license under any of its intellectual property rights nor the rights of others. **onsemi** products are not designed, intended, or authorized for use as a critical component in life support systems or any FDA Class 3 medical devices or medical devices with a same or similar classification in a foreign jurisdiction or any devices intended for implantation in the human body. Should Buyer purchase or use **onsemi** products for any such unintended or unauthorized application, Buyer shall indemnify and hold **onsemi** and its officers, employees, subsidiaries, affiliates, and distributors harmless against all claims, costs, damages, and expenses, and reasonable attorney fees arising out of, directly or indirectly, any claim of personal injury or death associated with such unintended or unauthorized use, even if such claim alleges that **onsemi** was negligent regarding the design or manufacture of the part. **onsemi** is an Equal Opportunity/Affirmative Action Employer. This literature is subject to all applicable copyright laws and is not for resale in any manner. Other names and brands may be claimed as the property of others.



ON Semiconductor®

FSA2268 / FSA2268T Low-Voltage Dual-SPDT (0.4Ω) Analog Switch with 16kV ESD

Features

- 0.4Ω Typical On Resistance (R_{ON}) for +3.0V Supply
- 0.25Ω Maximum R_{ON} Flatness for +3.0V Supply
- -3db Bandwidth: > 50MHz
- Low I_{CCT} Current Over an Expanded Control Input Range
- Packaged in Pb-free 10-Lead μ MLP (1.4 x 1.8mm)
- Power-Off Protection on Common Ports
- Broad V_{CC} Operating Range: 1.65 to 4.3V
- HBM JEDEC: JESD22-A114
 - I/O to GND: 13.5kV
 - Power to GND: 16.0kV
- Noise Immunity Termination Resistors in FSA2268T

Description

The FSA2268 is a high-performance, dual Single Pole Double Throw (SPDT) analog switch that features ultra-low R_{ON} of 0.4Ω (typical) at 3.0V V_{CC} . The FSA2268 operates over a wide V_{CC} range of 1.65V to 4.3V and is designed for break-before-make operation. The select input is TTL-level compatible.

The FSA2268 features very low quiescent current even when the control voltage is lower than the V_{CC} supply. This feature suits mobile handset applications by allowing direct interface with baseband processor general-purpose I/Os with minimal battery consumption.

The FSA2268T includes termination resistors that improve noise immunity during overshoot excursions, off-isolation coupling, or "pop-minimization."

Applications

- Cell Phone, PDA, Digital Camera, and Notebook
- LCD Monitor, TV, and Set-Top Box

Ordering Information

| Part Number | Top Mark | Package Description |
|-------------|----------|--|
| FSA2268UMX | GF | 10-Lead, Quad Ultrathin Molded Leadless Package (UMLP), 1.4 x 1.8mm, 0.4mm Pitch |
| FSA2268TUMX | GH | 10-Lead, Quad Ultrathin Molded Leadless Package (UMLP), 1.4 x 1.8mm, 0.4mm Pitch |
| FSA2268L10X | GH | 10-Lead, MicroPak™, 1.6mm Wide |

Analog Symbols

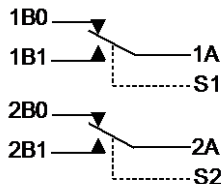

Figure 1. FSA2268

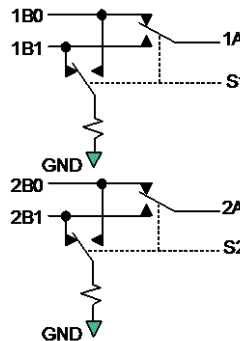

Figure 2. FSA2268T (with Noise Termination Resistors)

Pin Configuration

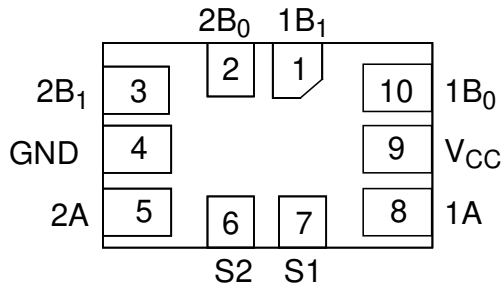

Figure 3. Pin Assignment 10-Pin UMLP (Top-Through View)

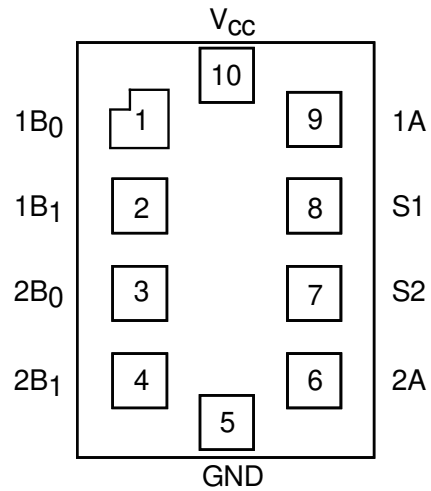

Figure 4. 10-Lead MicroPak™

Pin Descriptions

| Pin # UMLP | Pin # MicroPak™ | Name | Description |
|------------|-----------------|-----------------|--------------------|
| 1 | 2 | 1B ₁ | Data Ports |
| 2 | 3 | 2B ₀ | Data Ports |
| 3 | 4 | 2B ₁ | Data Ports |
| 4 | 5 | GND | Ground |
| 5 | 6 | 2A | Data Ports |
| 6 | 7 | S2 | Switch Select Pins |
| 7 | 8 | S1 | Switch Select Pins |
| 8 | 9 | 1A | Data Ports |
| 9 | 10 | V _{CC} | Supply Voltage |
| 10 | 1 | 1B ₀ | Data Ports |

Truth Table

| Control Input, S _n | Function |
|-------------------------------|--|
| LOW Logic Level | nB ₀ connected to nA (FSA2268/2268T); nB ₁ terminated to GND (FSA2268T only) |
| HIGH Logic Level | nB ₁ connected to nA (FSA2268/2268T); nB ₀ terminated to GND (FSA2268T only) |

Absolute Maximum Ratings

Stresses exceeding the absolute maximum ratings may damage the device. The device may not function or be operable above the recommended operating conditions and stressing the parts to these levels is not recommended. In addition, extended exposure to stresses above the recommended operating conditions may affect device reliability. The absolute maximum ratings are stress ratings only.

| Symbol | Parameter | Min. | Max. | Units | |
|--------------|---|---------------------------------|------|----------------|----|
| V_{CC} | Supply Voltage | -0.5 | 5.5 | V | |
| V_{SW} | Switch I/O Voltage ⁽¹⁾ | 1B0, 1B1, 2B0, 2B1, 1A, 2A Pins | -0.5 | $V_{CC} + 0.3$ | V |
| | | T Version nBn Pin Off | 0 | 1.4 | |
| V_{IN} | Control Input Voltage ⁽¹⁾ | -0.5 | 5.5 | V | |
| I_{IK} | Input Clamp Diode Current | | -50 | mA | |
| I_{SW} | Switch I/O Current (Continuous) | | 350 | mA | |
| I_{SWPEAK} | Peak Switch Current (Pulsed at 1ms Duration, <10% Duty Cycle) | | 500 | mA | |
| T_{STG} | Storage Temperature Range | -65 | +150 | °C | |
| T_J | Maximum Junction Temperature | | +150 | °C | |
| T_L | Lead Temperature (Soldering, 10 seconds) | | +260 | °C | |
| MSL | Moisture Sensitivity Level (JEDEC J-STD-020A) | | 1 | Level | |
| ESD | Human Body Model, JEDEC: JESD22-A114 | I/O to GND | | 13.5 | kV |
| | | Power to GND | | 16.0 | |
| | | All Other Pins | | 9.0 | |
| | Charged Device Model, JEDEC: JESD22-C101 | | 2.0 | kV | |

Note:

- Input and output negative ratings may be exceeded if input and output diode current ratings are observed.

Recommended Operating Conditions

The Recommended Operating Conditions table defines the conditions for actual device operation. Recommended operating conditions are specified to ensure optimal performance to the datasheet specifications. ON Semiconductor does not recommend exceeding them or designing to Absolute Maximum Ratings.

| Symbol | Parameter | Min. | Max. | Units |
|----------|-----------------------|------|----------|-------|
| V_{CC} | Supply Voltage | 1.65 | 4.30 | V |
| V_{IN} | Control Input Voltage | 0 | V_{CC} | V |
| V_{SW} | Switch I/O Voltage | 0 | V_{CC} | V |
| T_A | Operating Temperature | -40 | +85 | °C |

DC Electrical Characteristics

All typical values are at 25°C unless otherwise specified.

| Symbol | Parameter | Conditions | V _{CC} (V) | T _A =+25°C | | | T _A =-40 to +85°C | | Unit |
|--|--|---|---------------------|-----------------------|------|------|------------------------------|------|------|
| | | | | Min. | Typ. | Max. | Min. | Max. | |
| V _{IH} | Input Voltage High | | 3.6 to 4.3 | | | | 1.7 | | V |
| | | | 2.7 to 3.6 | | | | 1.5 | | |
| | | | 2.3 to 2.7 | | | | 1.4 | | |
| | | | 1.65 to 1.95 | | | | 0.9 | | |
| V _{IL} | Input Voltage Low | | 3.6 to 4.3 | | | | | 0.7 | V |
| | | | 2.7 to 3.6 | | | | | 0.5 | V |
| | | | 2.3 to 2.7 | | | | | 0.4 | |
| | | | 1.65 to 1.95 | | | | | 0.4 | |
| I _{IN} | Control Input Leakage (S1,S2) | V _{IN} =0 to V _{CC} | 1.65 to 4.30 | | | | -0.5 | 0.5 | μA |
| I _{NO(OFF)} , I _{NC(OFF)} FSA22268 | Off Leakage Current of Port nB0 and nB1 | nA=0.3V, V _{CC} =0.3V nB0 or nB1=V _{CC} -0.3V, 0.3V, or Floating Figure 6 | 1.95 to 4.30 | -10 | | 10 | -50 | 50 | nA |
| I _{NC(OFF)} FSA2268T | Off Leakage Current of Port nB0 and nB1 (with Termination Resistors) | nA=0.3V, nB0 or nB1=0V or Floating Figure 6 | 1.95 to 4.30 | -10 | | 10 | -50 | 50 | μA |
| I _{A(ON)} | On Leakage Current of Port nA | nA=0.3V, V _{CC} =0.3V nB0 or nB1=V _{CC} -0.3V, 0.3V, or Floating Figure 7 | 1.95 to 4.30 | -20 | | 20 | -100 | 100 | nA |
| I _{OFF} FSA2268 | Power-Off Leakage Current (Common Port Only 1A, 2A) | Common Port (1A, 2A), V _{IN} =0V to 4.3V, V _{CC} =0V nB0, nB1=Floating | 0V | | | | | ±1 | μA |
| I _{OFF} FSA2268T | Power-Off Leakage Current (Common Port Only 1A, 2A) | Common Port (1A, 2A), V _{IN} =0V to 4.3V, V _{CC} =0V nB0, nB1=0V or Floating | 0V | | | | | ±40 | μA |
| R _{ON} | Switch On Resistance ⁽²⁾⁽⁵⁾ | I _{ON} =100mA, nB0 or nB1=0.7V, 3.6V Figure 5 | 4.30 | | 0.30 | | | 0.50 | Ω |
| | | I _{ON} =100mA, nB0 or nB1=0.7V, 2.3V Figure 5 | 3.00 | | 0.40 | | | 0.55 | |
| | | I _{ON} =100mA, nB0 or nB1=0V, 0.7V, 1.6V, 2.3V Figure 5 | 2.30 | | 0.52 | | | | |
| | | I _{ON} =100mA, nB0 or nB1=0V, 0.7V, 1.65V Figure 5 | 1.65 | | 1.00 | | | | |
| ΔR _{ON} | On Resistance Matching Between Channels ⁽³⁾⁽⁵⁾ | I _{ON} =100mA, nB0 or nB1=0.7V | 4.30 | | 0.04 | | | 0.13 | Ω |
| | | | 3.00 | | 0.06 | | | 0.13 | |
| | | | 2.30 | | 0.12 | | | | |
| | | | 1.65 | | 1.00 | | | | |

Continued on following page...

DC Electrical Characteristics (Continued)

All typical values are at 25°C unless otherwise specified.

| Symbol | Parameter | Conditions | V _{CC} (V) | T _A =+25°C | | | T _A =-40 to +85°C | | Unit |
|-----------------------|---|---|---------------------|-----------------------|------|------|------------------------------|------|------|
| | | | | Min. | Typ. | Max. | Min. | Max. | |
| R _{FLAT(ON)} | On Resistance Flatness ⁽⁴⁾⁽⁵⁾ | I _{OUT} =100mA, nB0 or nB1=0V to V _{CC} | 4.30 | | | | | 0.25 | Ω |
| | | | 3.00 | | | | | 0.25 | |
| | | | 2.30 | | 0.5 | | | | |
| | | | 1.65 | | 0.6 | | | | |
| R _{TERM} | Internal Termination Resistors ⁽⁶⁾ | | | | 200 | | | | Ω |
| I _{CC} | Quiescent Supply Current | V _{IN} =0 or V _{CC} , I _{OUT} =0 | 4.30 | -100 | | 100 | -500 | 500 | nA |
| I _{CC(T)} | Increase in I _{CC} per Input | Input at 2.6V | 4.30 | | 3 | | | 7 | μA |
| | | Input at 1.8V | | | 7 | | | 15 | |

Notes:

2. On resistance is determined by the voltage drop between A and B pins at the indicated current through the switch.
3. $\Delta R_{ON} = R_{ON\ max} - R_{ON\ min}$ measured at identical V_{CC}, temperature, and voltage.
4. Flatness is defined as the difference between the maximum and minimum value of on resistance (R_{ON}) over the specified range of conditions.
5. Guaranteed by characterization, not production tested, for V_{CC}=1.65-3.00V.
6. Guaranteed by characterization, not production tested.

AC Electrical Characteristics

All typical value are for $V_{CC}=3.3V$ at $25^{\circ}C$ unless otherwise specified.

| Symbol | Parameter | Conditions | V_{CC} (V) | $T_A=+25^{\circ}C$ | | | $T_A=-40$ to $+85^{\circ}C$ | | Unit | Figure |
|-----------|---------------------------|---|--------------|--------------------|------|------|-----------------------------|------|------|----------------------|
| | | | | Min. | Typ. | Max. | Min. | Max. | | |
| t_{ON} | Turn-On Time | nB0 or nB1=1.5V, $R_L=50\Omega$, $C_L=35pF$ | 3.6 to 4.3 | | | 55 | 15 | 60 | ns | Figure 8 Figure 9 |
| | | | 2.7 to 3.6 | | | 60 | 15 | 65 | | |
| | | | 2.3 to 2.7 | | | 65 | 15 | 70 | | |
| | | | 1.65 to 1.95 | | 70 | | | | | |
| t_{OFF} | Turn-Off Time | nB0 or nB1=1.5V, $R_L=50\Omega$, $C_L=35pF$ | 3.6 to 4.3 | | | 30 | 5 | 35 | ns | Figure 8 Figure 9 |
| | | | 2.7 to 3.6 | | | 35 | 5 | 40 | | |
| | | | 2.3 to 2.7 | | | 40 | 5 | 45 | | |
| | | | 1.65 to 1.95 | | 40 | | | | | |
| t_{BBM} | Break-Before-Make Time | nB0 or nB1=1.5V, $R_L=50\Omega$, $C_L=35pF$ | 3.6 to 4.3 | | 15 | | 2 | | ns | Figure 10 |
| | | | 2.7 to 3.6 | | 15 | | 2 | | | |
| | | | 2.3 to 2.7 | | 15 | | 2 | | | |
| | | | 1.65 to 1.95 | | 16 | | 2 | | | |
| Q | Charge Injection | $C_L=1.0nF$, $V_S=0V$, $R_S=0\Omega$ | 1.65 to 4.30 | | 25 | | | | pC | Figure 14 |
| OIRR | Off Isolation | $f=100kHz$, $R_L=50\Omega$, $C_L=0pF$ | 1.65 to 4.30 | | -70 | | | | dB | Figure 12 |
| Xtalk | Crosstalk | $f=100kHz$, $R_L=50\Omega$, $C_L=0pF$ | 1.65 to 4.30 | | -70 | | | | dB | Figure 13 |
| BW | -3db Bandwidth | $R_L=50\Omega$, $C_L=0pF$ | 1.65 to 4.30 | | >50 | | | | MHz | Figure 11 |
| THD | Total Harmonic Distortion | $f=20Hz$ to $20kHz$, $R_L=32\Omega$, $V_{IN}=2V_{pp}$ | 1.65 to 4.30 | | .06 | | | | % | Figure 17 |

Capacitance

| Symbol | Parameter | Conditions | V_{CC} (V) | $T_A=+25^{\circ}C$ | | | Unit | Figure |
|-----------|-------------------------------|------------|--------------|--------------------|------|------|------|-----------|
| | | | | Min. | Typ. | Max. | | |
| C_{IN} | Control Pin Input Capacitance | $f=1MHz$ | 0 | | 1.5 | | pF | Figure 15 |
| C_{OFF} | B Port Off Capacitance | $f=1MHz$ | 3.3 | | 30 | | pF | Figure 15 |
| C_{ON} | A Port On Capacitance | $f=1MHz$ | 3.3 | | 120 | | pF | Figure 16 |

Test Diagrams

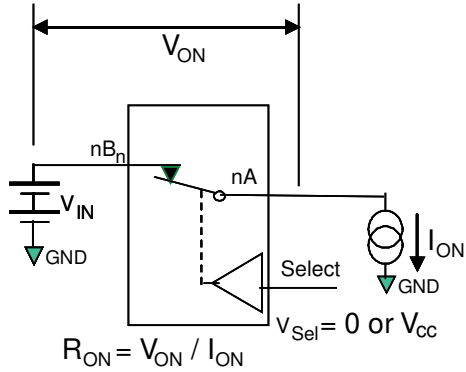

Figure 5. On Resistance

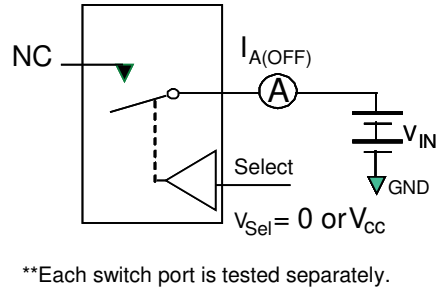

Figure 6. Off Leakage (Ports tested separately)

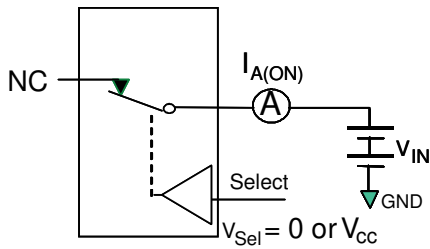

Figure 7. On Leakage

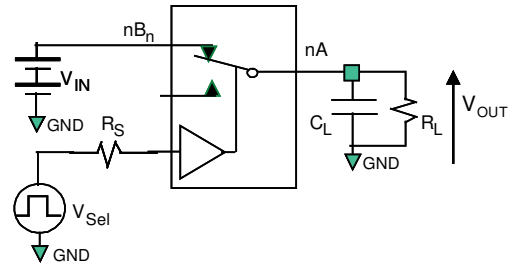

Figure 8. Test Circuit Load

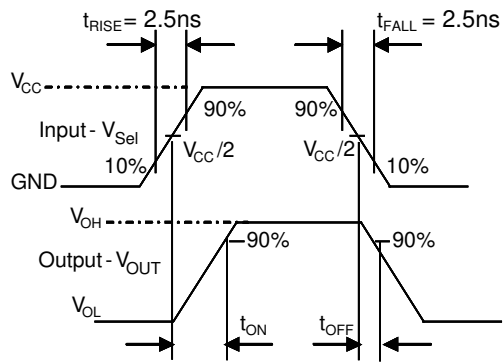

Figure 9. Turn-On / Turn-Off Waveforms

Test Diagrams (Continued)

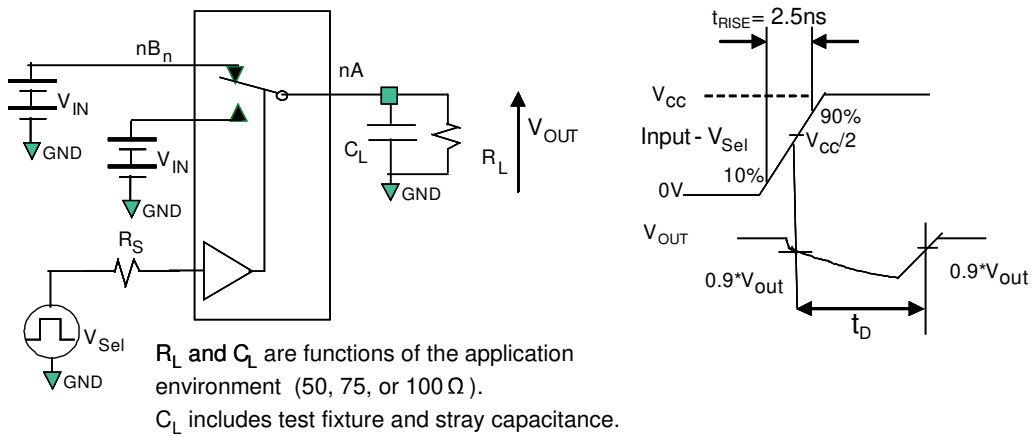

Figure 10. Break-Before-Make Interval Timing

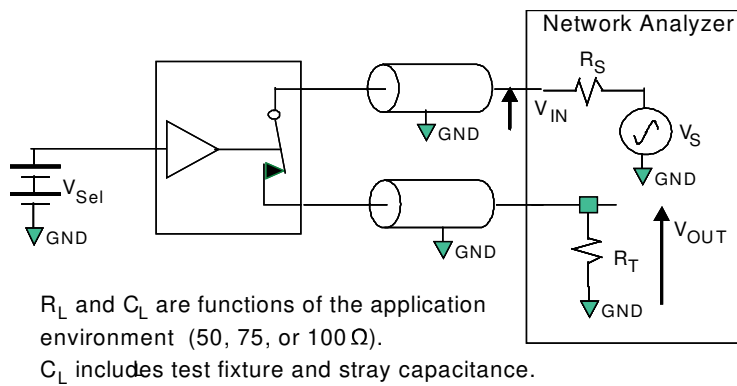

Figure 11. Bandwidth

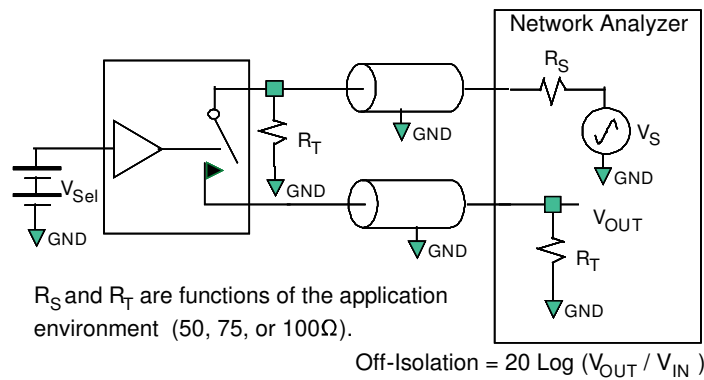

Figure 12. Channel Off Isolation

Test Diagrams (Continued)

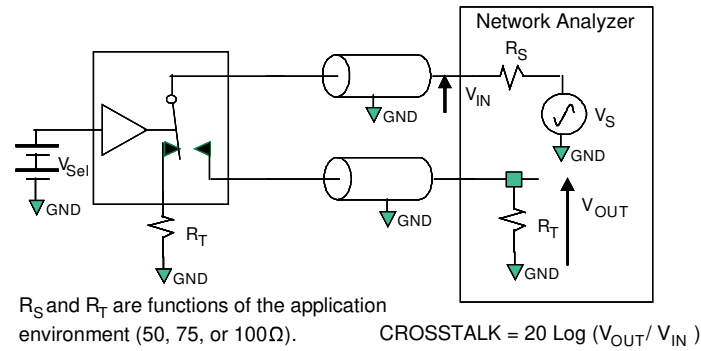

Figure 13. Adjacent Channel Crosstalk

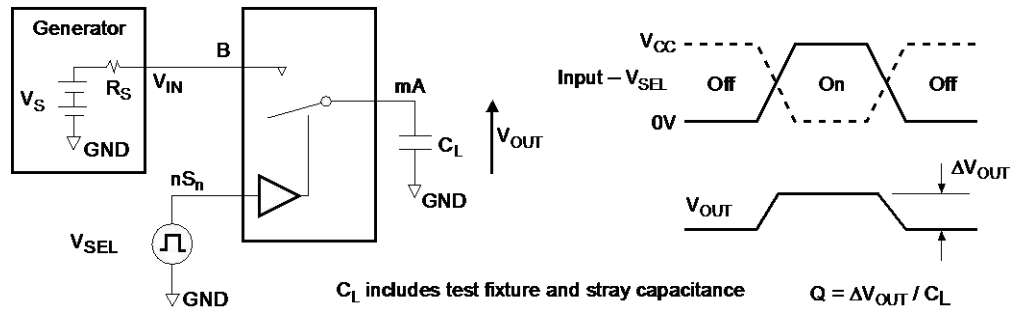

Figure 14. Charge Injection Test

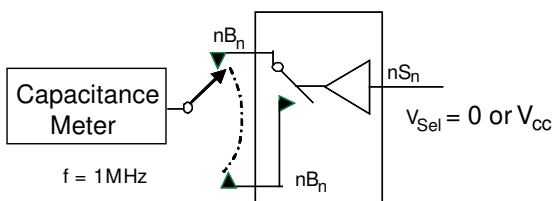

Figure 15. Channel Off Capacitance

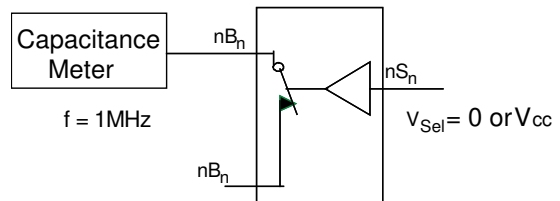

Figure 16. Channel On Capacitance

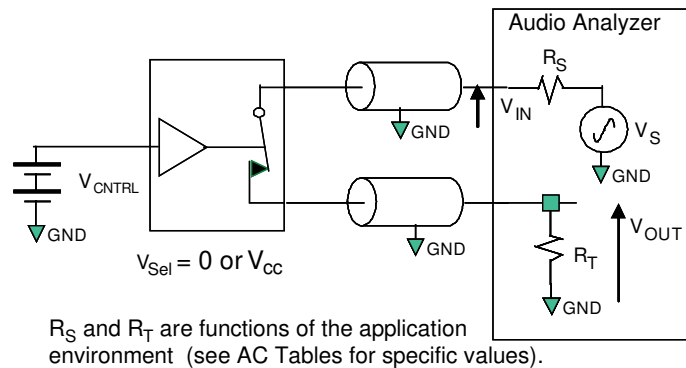

Figure 17. Total Harmonic Distortion

Physical Dimensions

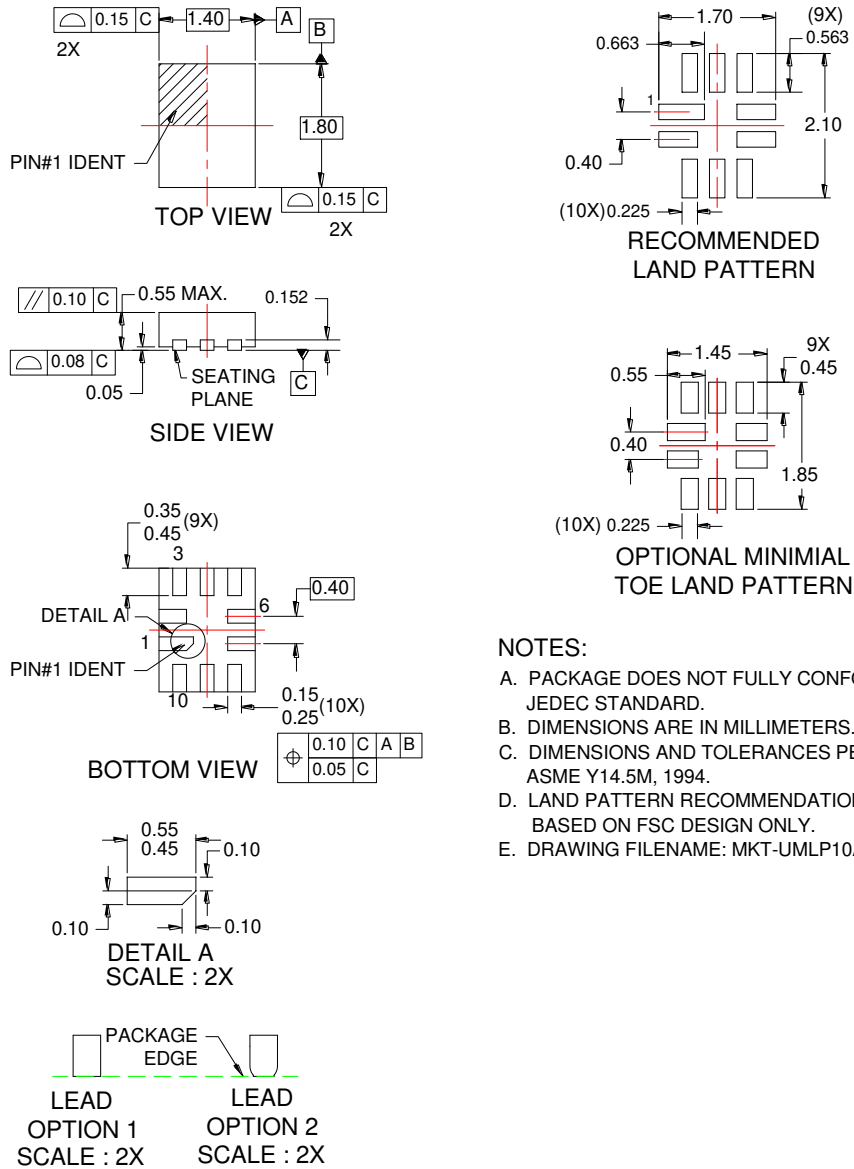

Figure 18. 10-Lead Quad Ultrathin Molded Leadless Package (UMLP)

Package drawings are provided as a service to customers considering ON Semiconductor components. Drawings may change in any manner without notice. Please note the revision and/or date on the drawing and contact a ON Semiconductor representative to verify or obtain the most recent revision. Package specifications do not expand the terms of ON Semiconductor's worldwide terms and conditions, specifically the warranty therein, which covers ON Semiconductor products.

Physical Dimensions (Continued)

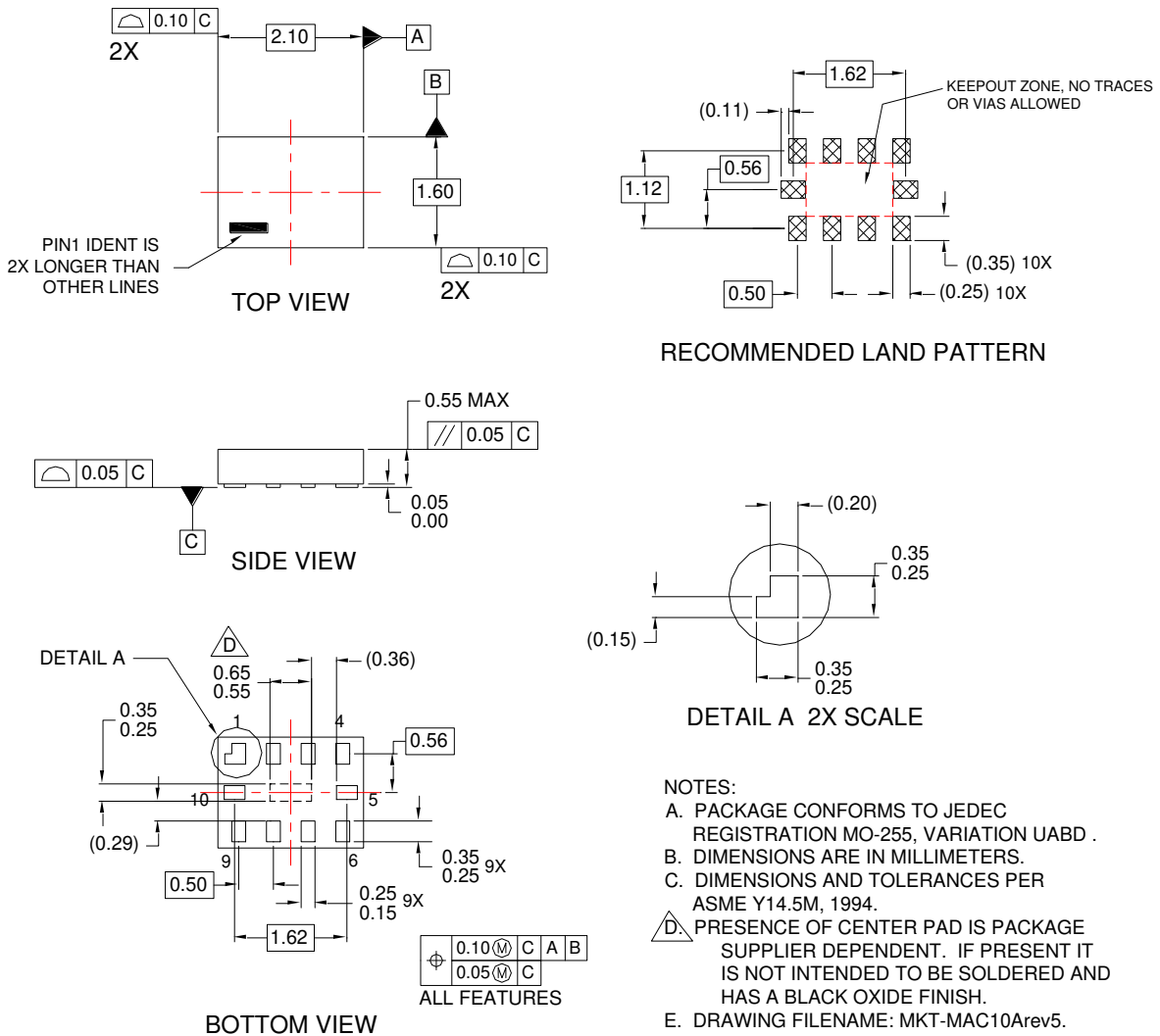



Figure 19. 10-Lead, MicroPak™, 1.6mm Wide

Package drawings are provided as a service to customers considering ON Semiconductor components. Drawings may change in any manner without notice. Please note the revision and/or date on the drawing and contact a ON Semiconductor representative to verify or obtain the most recent revision. Package specifications do not expand the terms of ON Semiconductor's worldwide terms and conditions, specifically the warranty therein, which covers ON Semiconductor products.

ON Semiconductor and  are trademarks of Semiconductor Components Industries, LLC dba ON Semiconductor or its subsidiaries in the United States and/or other countries. ON Semiconductor owns the rights to a number of patents, trademarks, copyrights, trade secrets, and other intellectual property. A listing of ON Semiconductor's product/patent coverage may be accessed at www.onsemi.com/site/pdf/Patent-Marking.pdf. ON Semiconductor reserves the right to make changes without further notice to any products herein. ON Semiconductor makes no warranty, representation or guarantee regarding the suitability of its products for any particular purpose, nor does ON Semiconductor assume any liability arising out of the application or use of any product or circuit, and specifically disclaims any and all liability, including without limitation special, consequential or incidental damages. Buyer is responsible for its products and applications using ON Semiconductor products, including compliance with all laws, regulations and safety requirements or standards, regardless of any support or applications information provided by ON Semiconductor. "Typical" parameters which may be provided in ON Semiconductor data sheets and/or specifications can and do vary in different applications and actual performance may vary over time. All operating parameters, including "Typicals" must be validated for each customer application by customer's technical experts. ON Semiconductor does not convey any license under its patent rights nor the rights of others. ON Semiconductor products are not designed, intended, or authorized for use as a critical component in life support systems or any FDA Class 3 medical devices or medical devices with a same or similar classification in a foreign jurisdiction or any devices intended for implantation in the human body. Should Buyer purchase or use ON Semiconductor products for any such unintended or unauthorized application, Buyer shall indemnify and hold ON Semiconductor and its officers, employees, subsidiaries, affiliates, and distributors harmless against all claims, costs, damages, and expenses, and reasonable attorney fees arising out of, directly or indirectly, any claim of personal injury or death associated with such unintended or unauthorized use, even if such claim alleges that ON Semiconductor was negligent regarding the design or manufacture of the part. ON Semiconductor is an Equal Opportunity/Affirmative Action Employer. This literature is subject to all applicable copyright laws and is not for resale in any manner.

PUBLICATION ORDERING INFORMATION

LITERATURE FULFILLMENT:

Literature Distribution Center for ON Semiconductor
19521 E. 32nd Pkwy, Aurora, Colorado 80011 USA
Phone: 303-675-2175 or 800-344-3860 Toll Free USA/Canada
Fax: 303-675-2176 or 800-344-3867 Toll Free USA/Canada
Email: orderlit@onsemi.com

N. American Technical Support: 800-282-9855 Toll Free
USA/Canada
Europe, Middle East and Africa Technical Support:
Phone: 421 33 790 2910
Japan Customer Focus Center
Phone: 81-3-5817-1050

ON Semiconductor Website: www.onsemi.com
Order Literature: <http://www.onsemi.com/orderlit>
For additional information, please contact your local
Sales Representative