

FEMALE M12 RIGHT ANGLE TO MALE M12 STRAIGHT CORDSET

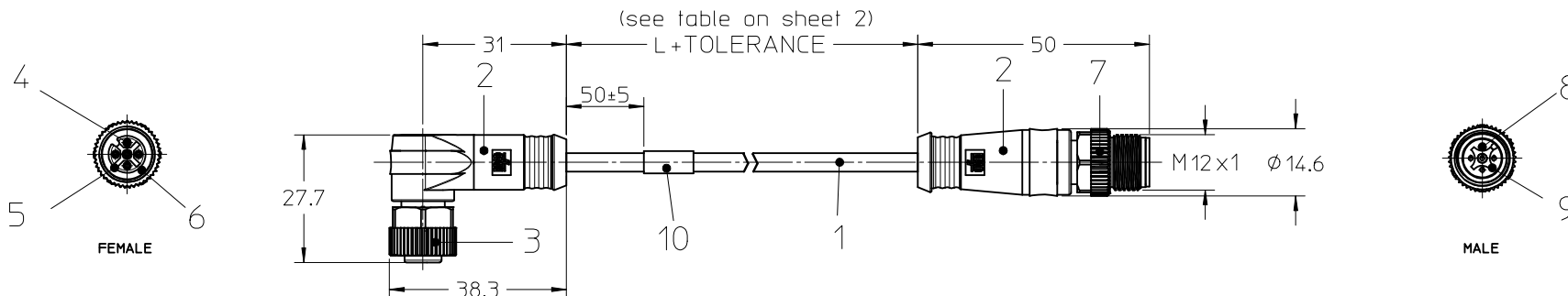

NOTES:

TEMPERATURE RANGE	SEE TABLE ON SHEET 2
CONTACT CURRENT RATING	3-5 POLES 4A 8 POLES 2A
VOLTAGE RATING	3-4 POLES 250V 5 POLES 60V 8 POLES 30V
PROTECTION CLASS	IP 67

TOLERANCES:	
≤ 1m	+40 mm
1m - 5m	+60 mm
5m - 10m	+80 mm
> 10m	+140 mm
> 20m	+160 mm
> 30m	+1%

Mating face view:

Shield connected to the housing

M12S 3 POLE	M12S 4 POLE	M12S 5 POLE	M12S 8 POLE
MALE	MALE	MALE	MALE
FEMALE	FEMALE	FEMALE	FEMALE
PIN # WIRE	PIN # WIRE	PIN # WIRE	PIN # WIRE
1 BROWN 2 - 3 BLUE 4 BLACK 5 -	1 BROWN 2 WHITE 3 BLUE 4 BLACK 5 -	1 BROWN 2 WHITE 3 BLUE 4 BLACK 5 GREY	1 WHITE 2 BROWN 3 GREEN 4 YELLOW 5 GREY 6 PINK 7 BLUE 8 RED
CODING REQUIRED TO IEC 61076-2-101			

Bill of Materials

ITEM	QTY.	DESCRIPTION	MATERIAL	FINISH
10	1	LABEL	-	-
9	1	INSERT XP MALE M12 SHIELD	PUR	BLACK
8	X	PIN MALE	BRASS	GOLD OVER NICKEL
7	1	KNU/HEX NUT M12 MALE	BRASS	CuNi3B
6	1	O-RING	FPM	RED
5	1	INSERT XP FEMALE M12 SHIELD	PUR	BLACK
4	X	CONTACT FEMALE	BRASS	GOLD OVER NICKEL
3	1	KNU/HEX NUT M12 FEMALE	BRASS	CuNi3B
2	-	OVERMOULD	TPU	BLACK
1	-	CABLE	SEE TABLE (SHEET 2)	-
ITEM	QTY.	DESCRIPTION	MATERIAL	FINISH

ORIGINAL RELEASE EC NO: IPG2015-0505 DRW:WSTRASZKIEWI 2014/12/08 CHKD:JMARSZALEK 2014/12/08 APPR:MIWASIECZKO 2014/12/11	QUALITY SYMBOLS ▽=0 ◻=0	GENERAL TOLERANCES (UNLESS SPECIFIED)		DIMENSION STYLE		SCALE	DESIGN UNITS	THIRD ANGLE PROJECTION	
				MM ONLY		---	METRIC		
				mm	INCH	DRAWN BY DATE			TITLE
						WSTRASZKIEWI 2014/12/08			CSE M12 M12 XP AC FE RA TPU MA STR XM
				CHECKED BY DATE					
				JMARSZALEK 2014/12/08					
				APPROVED BY DATE					
				MIWASIECZKO 2014/12/11					
				MATERIAL NO.		DOCUMENT NO.			
				SEE TABLE		SD-120069-029			
				SIZE		SHEET NO.			
				A3		1 OF 2			
				THIS DRAWING CONTAINS INFORMATION THAT IS PROPRIETARY TO MOLEX INCORPORATED AND SHOULD NOT BE USED WITHOUT WRITTEN PERMISSION					

PART LIST

MOLEX PN	ENGINEERING No.	CABLE LENGTH "L" IN M
1200698684	883S31BS1M010	1M
1200698685	883S31BS1M020	2M
1200698686	883S31BS1M030	3M
1200698687	883S31BS1M050	5M
1200698688	883S31BS1M100	10M
1200698689	884S31BS1M010	1M
1200698690	884S31BS1M020	2M
1200698691	884S31BS1M030	3M
1200698692	884S31BS1M050	5M
1200698693	884S31BS1M100	10M
1200698694	885S31BS1M010	1M
1200698695	885S31BS1M020	2M
1200698696	885S31BS1M030	3M
1200698697	885S31BS1M050	5M
1200698698	885S31BS1M100	10M
1200698699	888S31BS2M010	1M
1200698700	888S31BS2M020	2M
1200698701	888S31BS2M030	3M
1200698702	888S31BS2M050	5M
1200698703	888S31BS2M100	10M

NUMERICAL CODE

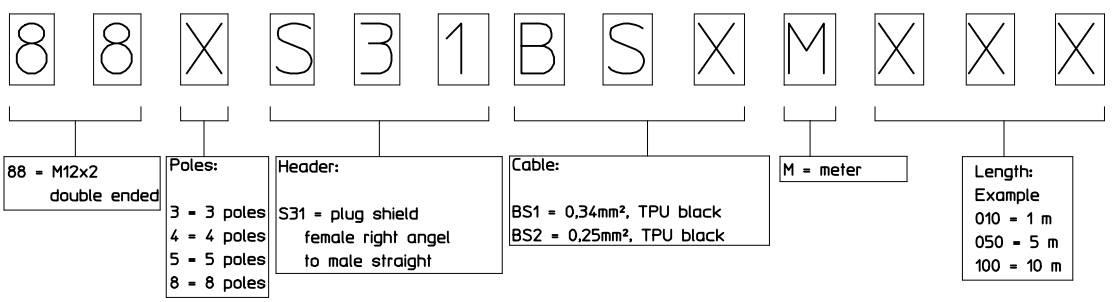

CABLE SPECIFICATION

CABLE TYPE	WIRE GAUGE	CABLE JACKET	UL	CSA	static	flexing	drag chain tested	shield	other
BS1 3P, 4P, 5P	0.34mm ²	TPU black	STYLE 21215	yes	-40°C to +90°C 5xD	-25°C to +80°C 7.5xD	5 mio cycles	braid	WELD SLAG RESISTANCE
BS2 8P	0.25mm ²	TPU black	STYLE 21215	yes	-40°C to +90°C 5xD	-25°C to +80°C 7.5xD	5 mio cycles	braid	WELD SLAG RESISTANCE

For Raw Cable Specification see SD-120209-003

ORIGINAL RELEASE EC NO: IPG2015-0505 DRWN:WSTRASZKIEWI 2014/12/08 CHKD:JMARSZALEK 2014/12/08 APPR:MIWASIECZKO 2014/12/11	DESCRIPTION REV	QUALITY SYMBOLS ▽=0 ◻=0	GENERAL TOLERANCES (UNLESS SPECIFIED)	DIMENSION STYLE MM ONLY	SCALE ---	DESIGN UNITS METRIC	THIRD ANGLE PROJECTION	
			mm INCH	DRAWN BY DATE	TITLE	CSE M12 M12 XP AC FE RA TPU MA STR XM molex SD-120069-029 SHEET NO. 2 OF 2		
		4 PLACES	± --- ± ---	WSTRASZKIEWI 2014/12/08				
		3 PLACES	± --- ± ---	CHECKED BY DATE				
		2 PLACES	± --- ± ---	JMARSZALEK 2014/12/08				
1 PLACE	± --- ± ---	APPROVED BY DATE						
0 PLACE	± --- ± ---	MIWASIECZKO 2014/12/11						
	ANGULAR ± 1 °	MATERIAL NO.	SEE TABLE	DOCUMENT NO.				
	DRAFT WHERE APPLICABLE MUST REMAIN WITHIN DIMENSIONS	SIZE A3	THIS DRAWING CONTAINS INFORMATION THAT IS PROPRIETARY TO MOLEX INCORPORATED AND SHOULD NOT BE USED WITHOUT WRITTEN PERMISSION					