

FDC2214 Proximity and Capacitive Touch EVM User's Guide

Contents

1	Overview	2
2	Hardware.....	3
	2.1 Grounded versus Floating Systems	3
	2.2 Proximity Sensor	4
	2.3 Capacitive Touch Buttons	4
	2.4 Reset Button.....	5
	2.5 Optional Features Descriptions	5
	2.6 Additional Debugging Features	6
3	Firmware	6
	3.1 FDC2214 Register Configuration	6
	3.2 Programming	7
4	Setup	7
5	Operation	8
6	Board Layout.....	10
7	Schematic	13

List of Figures

1	FDC2214 Proximity and Capacitor Touch Sensing EVM.....	2
2	System Level Block Diagram.....	3
3	Component Layout Location of Board on Top Side and Bottom Side	3
4	Sensor Size Area Versus Sensing Distance	4
5	Comparison of Capacitance vs Target Position for Covered and Non-covered Sensors	5
6	: JTAG Pin Out Diagram	7
7	Proximity Sensor Waveform (Yellow), Cap Touch Button 1/2 Waveforms (Green and Magenta)	8
8	Proximity Startup Waveform (Yellow), Cap Touch Button 1/2 Startup Waveforms (Green, Magenta)	9
9	Sensor Multiplexing – Proximity (Yellow), Cap Touch Button 1 and 2 (Green, Magenta)	9
10	Composite Top and Bottom Layer Plot (Viewed From the Top)	10
11	Top Layer.....	10
12	Midlayer 1 (Power Plane)	11
13	Midlayer 2 (GND Plane)	11
14	Bottom Layer.....	12
15	Schematic	13

List of Tables

1	Optional Feature Use Cases	5
2	FDC2214 Register Configuration	6
3	JTAG Connector Pin Assignment.....	7
4	Proximity and Capacitive Touch Sensor Properties.....	8

All trademarks are the property of their respective owners.

1 Overview

The FDC2214 proximity and capacitive touch button board demonstrates the use of TI's capacitive sensing technology to sense and measure the presence of various objects. The board is a complete hardware and firmware solution that integrates the FDC2214, MSP430FR5969, and TPS61029 into one design. The firmware included processes the data from one proximity sensor and two capacitive touch buttons via the FDC2214 to determine whether an object is in the intended sensing area. All of the processing is done on the MSP430 allowing the board to be a standalone system. Dedicated colored LEDs light up once the device detects a target in close proximity to the board or detects a press on the buttons. The board is designed to operate with one AA-battery. The maximum sensing distance that can be reliably achieved with the board is 10 cm (4 inches) as a floating system and 50 cm (19.6 inches) as a grounded system. The cap touch buttons and firmware have been optimized to be very responsive to quick user touch interactions.

The hardware uses the 4-channel FDC2214 to multiplex through each of the three capacitive sensors: one proximity sensor and two capacitive touch buttons. As the firmware in the MSP430 detects a user approaching the board, a green LED lights up to indicate that an object has been detected. If the user touches Button1, Button2, or both of them simultaneously, their corresponding red LED lights up. The board integrates the FDC2214, MSP430FR5969 and the TPS61029 as a complete standalone system. [Figure 1](#) shows the top side of the reference design.

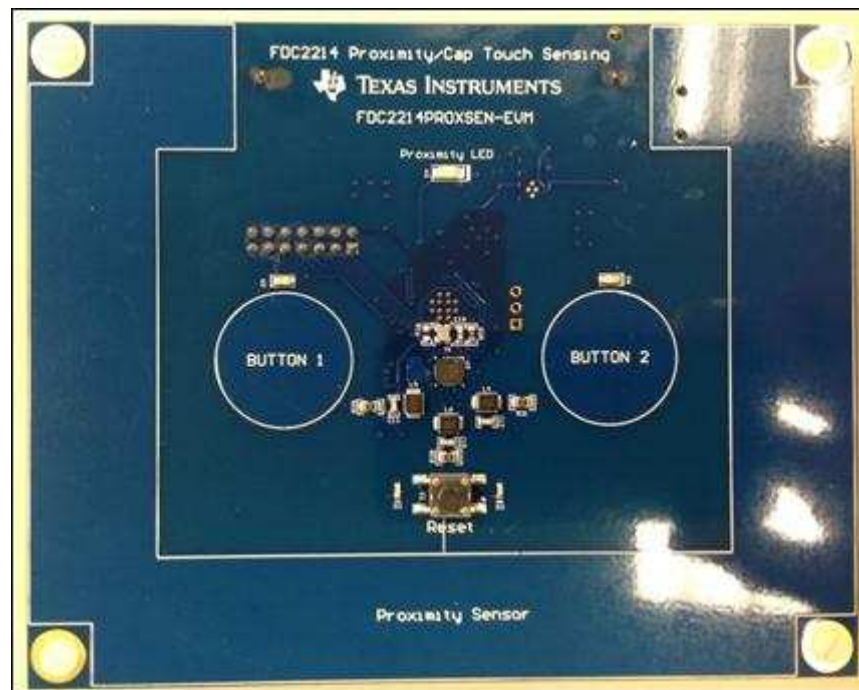

Figure 1. FDC2214 Proximity and Capacitor Touch Sensing EVM

2 Hardware

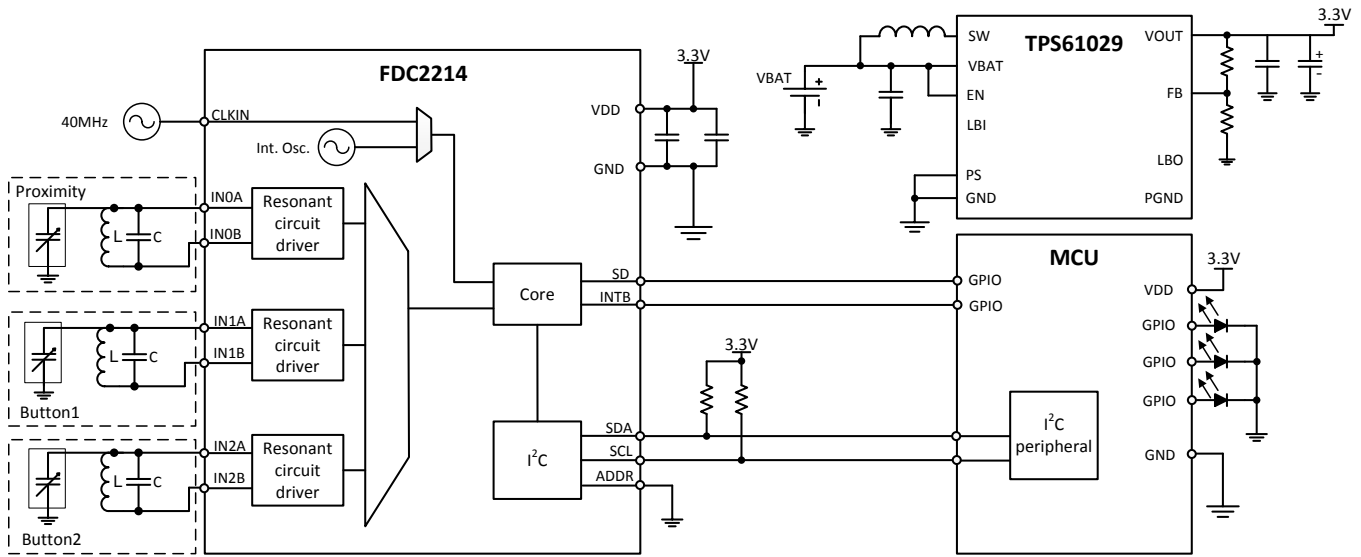

Figure 2. System Level Block Diagram

Figure 3 illustrates the features of the top side and bottom side of the board. The proximity sensor consists of a copper bezel arranged around the perimeter of the board. The board is 10.16 cm by 12.7 cm (4 x 5 inches). The proximity sensor is 19.05 mm (0.75 inches) wide and conforms to the edges of the board. The buttons are 20.32 mm (0.8 inches) diameter sensors arranged in the center of the board. A cut out on the proximity sensor where the battery is located is necessary since the battery acts as a ground. This limits the amount of direct capacitive coupling seen by the sensor.

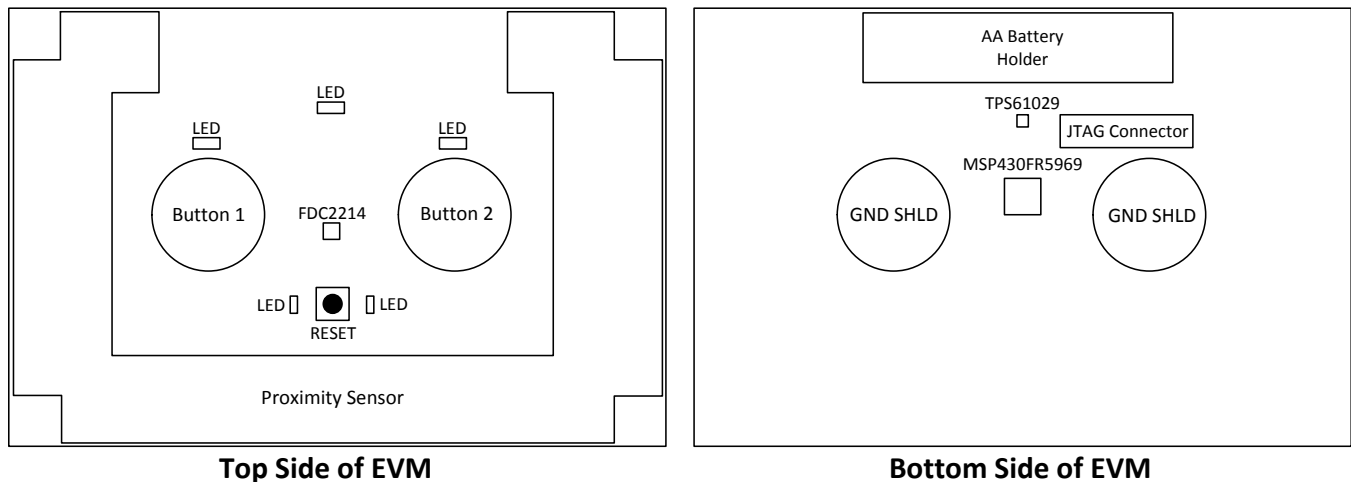

Figure 3. Component Layout Location of Board on Top Side and Bottom Side

2.1 Grounded versus Floating Systems

There are two typical scenarios in how a capacitive sensing system is designed relative to its ground reference: a grounded system and a floating system. A grounded system means the system is referenced to or very close to earth ground. A floating system means the system is referenced to the “ground” reference of the source that is generating the power for the system, for example a battery. As an example, a laptop that is operating with its charger connected to a wall outlet is grounded whereas a laptop powered solely on its battery is a floating system.

The sensitivity of a grounded system is more significant compared to a floating system, especially if the intended target is the human body. The human body will have a voltage potential close to earth ground (same or close to system ground) while the voltage potential of the floating system can be significantly different. This difference in potential directly corresponds to a difference in sensitivity or sensing distance. This EVM uses a AA-battery as its power source so

2.2 Proximity Sensor

The proximity sensor on the board was designed to detect a human hand at 50 cm using a grounded system and 10 cm with a floating system. Sensitivity is defined as maximum sensing distance, at which point the shift in the measured capacitance exceeds the detection threshold, which is determined by the system noise level. Figure 4 shows a plot of the sensing distance the FDC2214 can achieve with a given sensor size area in a grounded system. A solid square sensor was used to collect the data in Figure 4.

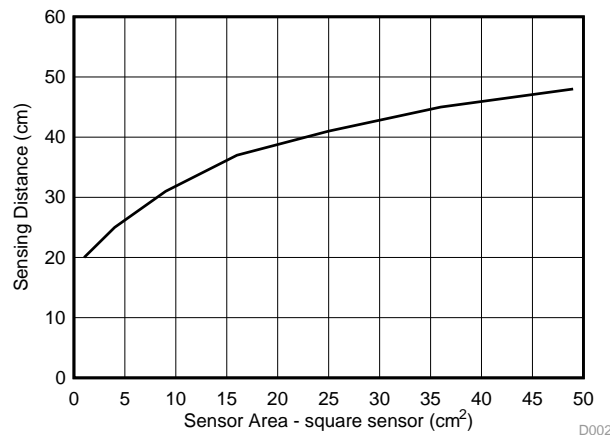

Figure 4. Sensor Size Area Versus Sensing Distance

The proximity sensor on the EVM is designed around the edges of the board in a bezel configuration. The actual sensor size area is 59 cm² with the spatial sensor size area spanning 121 cm². All of the electronics are located in the middle of the proximity sensor.

One of the major factors that affect sensitivity of a proximity sensor is the size and location of the nearest ground potential. The layout of the board minimizes the ground plane as much as possible. A ground plane underneath the sensor significantly reduces sensitivity. For example, if a ground shield is directly below and the same size as the sensor, sensitivity is reduced by 50%. Noise in the system and in the environment also affects sensing performance.

The system was optimized and tested in a low noise environment. Variations and false triggers may occur depending on the surrounding environment. The algorithm thresholds in the firmware may need to be adjusted accordingly to fit a specific environment condition

2.3 Capacitive Touch Buttons

The circular buttons measure 20.32 mm (0.8 inches) in diameter. Capacitive touch buttons require less attention to sensitivity in terms detecting small changes in capacitance simply because the intent is to detect a touch event. Typically, changes in capacitance on the order of picofarads are required in detecting button presses. The same factors that affect sensitivity for proximity still apply for capacitive touch buttons. A solid or hatched ground pad/shield underneath the button sensor can be used to moderate the sensitivity of the button and mitigate unintentional touch events.

In most applications, the user interacts with the button sensor directly. In some applications, there may be a protective cover or a piece of isolation material to prevent direct contact with the sensor (for quality and reliability purposes). Sensitivity performance is dependent on the material and thickness of the material. Figure 5 shows a simulated sensitivity analysis for a proximity sensor. Capacitive touch buttons rely on a large response to determine when a press is detected directly on the sensor. The simulation shows that at close range, including the touch condition, a protective cover (in this case PVC) can actually enhance the response. However, this effect is observed over a limited range and at longer ranges shows little impact.

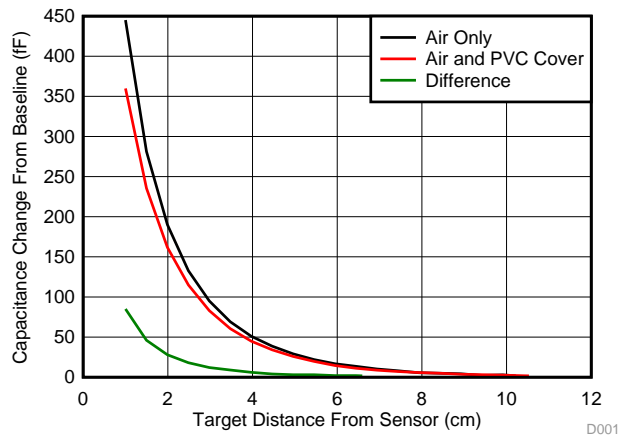

Figure 5. Comparison of Capacitance vs Target Position for Covered and Non-covered Sensors

2.4 Reset Button

A reset button (Figure 3) is included in the design to perform a soft reset to the system if there are any disruptions to the board relative to its environment. For example, if the board is picked up and moved to a different area, its baseline capacitance can dramatically change. The derivative-integration algorithm implemented in this system may take some time to recover from this change in the baseline capacitance, so the reset button can be used to eliminate this recovery time. Once the reset button is pressed, LED D2 and D3 near the button temporarily light up indicating that an initial calibration is being performed.

NOTE: A two second delay is implemented prior to the calibration process. During calibration, no target or object should be in the intended sensing area. The LEDs turn off after calibration and the system is fully operational.

2.5 Optional Features Descriptions

There are several optional features (Table 1) implemented in the design that can be suitable for future system investigations:

Table 1. Optional Feature Use Cases

Part Designator	Description	Use Case
J3	3 GPIO pinouts on a 3 pin 100 mil header	Debug and prototype
R24	Pull-up resistor on the supply pin of the FDC2214	Allows for current measurements for low power (LP) applications
R25	Pull-up resistor on the supply pin of the external oscillator	Power gating to reduce current for LP applications
R26	Pull-down resistor on the enable pin of the external oscillator	Enable gating to reduce current consumption for LP application
R28, R29, R31	Series resistors on channel inputs of FDC2214 to sensors	Connecting external sensors for evaluation and prototyping purposes
R32, R34	Resistors to connect GND SHLD capabilities	Understanding how ground shields affect sensitivity and interference

2.6 Additional Debugging Features

There are several hooks integrated in the design to debug the power supply rails and the I2C bus lines. To debug the system in real time, the backchannel UART on the MSP-FET tool is connected to the UART_A1 module on the MSP430FR5969. The JTAG connector pins 12 and 14 (blue colored pins in [Figure 6](#)) correspond to the transmit and receive signal lines respectively. The firmware implements functions to transmit ASCII characters to a PC serial COM port host. The backchannel UART is disabled (relevant code is commented out) in the firmware by default. To enable the UART functions, uncomment the UART code, recompile the firmware, and load it to the MSP430 to use this functionality.

3 Firmware

3.1 FDC2214 Register Configuration

The full set of register contents used to configure the FDC2214 for this application can be found in [Table 2](#).

Table 2. FDC2214 Register Configuration

Register Address	Name	Value	Description
0x08	RCOUNT_CH0	0x9C40	RCOUNT of 40000 (~16 ms conversion time)
0x09	RCOUNT_CH1	0x03E8	RCOUNT of 1000 (~400 μ s conversion time)
0x0A	RCOUNT_CH2	0x03E8	RCOUNT of 1000 (~400 μ s conversion time)
0x10	SETTLECOUNT_CH0	0x0064	100 cycles before measurement taken
0x11	SETTLECOUNT_CH1	0x0064	100 cycles before measurement taken
0x12	SETTLECOUNT_CH2	0x0064	100 cycles before measurement taken
0x19	ERROR_CONFIG	0x0001	Report data ready flag by asserting INTB pin
0x1A	CONFIG	0x1E01	Active mode enabled Low power activation mode enabled Reference frequency provided from CLKIN pin INTB pin enabled Normal sensor drive current enabled
0x1B	MUX_CONFIG	0xA20D	Auto-scan conversions enabled Auto-scan sequence: Ch0, Ch1, CH2 Deglitch filter: 10 MHz
0x1E	DRIVE_CURRENT_CH0	0x5000	Current drive set to 0.069 mA
0x1F	DRIVE_CURRENT_CH1	0x5800	Current drive set to 0.081 mA
0x20	DRIVE_CURRENT_CH2	0x5800	Current drive set to 0.081 mA

3.2 Programming

Programming new firmware on to the MSP430 through Code Composer Studio (CCS) can be performed in two ways:

- MSP-FET emulation tool via JTAG connector
- Spy-by-wire from an MSP430 LaunchPad

The JTAG connector (as shown in [Figure 6](#)) can be used with the MSP-FET tool for programming. [Table 3](#) shows the signal names assigned to the pins of the JTAG connector. The JTAG is not populated by default so the connector or 100 mil pitched headers need to be soldered on to the board to use for programming and debugging

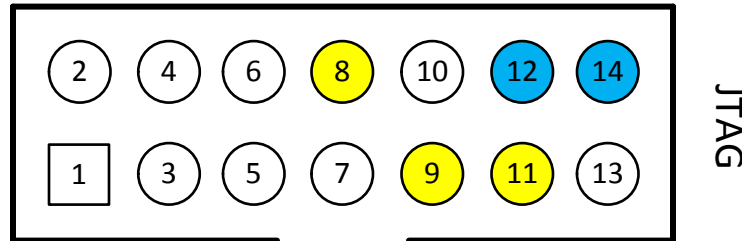

Figure 6. : JTAG Pin Out Diagram

Table 3. JTAG Connector Pin Assignment

Pin	Signal	Description
1	TDO	JTAG data output
2	VCC_TOOL	JTAG voltage selection from tool
3	TDI	JTAG data input and TCLK input
4	VCC_TARGET	Not Connected
5	TMS	Signal to control the JTAG state machine
6	NC	Not connected
7	TCK	JTAG clock input
8	SBWTCK	Spy-by-wire clock
9	GND	Ground
10	NC	Not connected
11	SBWTDIO	Spy-by-wire bidirectional signal IO
12	A1_TX	UART_A1 transmit signal (for debugging)
13	NC	Not Connected
14	A1_RX	UART_A1 receive signal (for debugging)

For spy-by-wire interface programming, [Figure 6](#) indicates the yellow colored pins 8, 9, and 11 (SBWTCK, GND, and SBWTDIO) that need to be connected to the isolation block connections on the MSP430 LaunchPad. SBWRST and SBWTST pins on the LaunchPad need to be connected to SBWTDIO and SBWTCK test points, respectively. A common ground is required between the board and LaunchPad for proper operation.

4 Setup

The EVM is designed as a standalone system to run off of one AA-battery. All of the processing and object detection indications occur on the EVM. To maximize sensing distance, it is recommended to ensure that the surface is non-conductive and not grounded. The proximity sensing algorithm detects changes in capacitances on the order of 1fF so it is recommended to fix the position of the board or not move the board during evaluation to limit any false detection.

5 Operation

Once the EVM is powered ON, the entire system starts running. LED D2 and D3 near the reset button temporarily light up indicating that an initial calibration is being performed. A two second delay is implemented prior to the calibration process. During calibration, no target or object should be in the intended sensing area. The LEDs turns off after calibration and the system is fully operational.

Table 4 shows the signal properties of the proximity sensor and one of the capacitive touch buttons. They were obtained by probing either INA or INB of each channel with an oscilloscope. Figure 7 through Figure 9 illustrate the waveforms for the proximity sensor and the capacitive touch buttons. The recommended voltage amplitude for the oscillation waveform is between 1.2 and 1.8 V_{PP}. Anything over 1.8 V_{PP} is not recommended because the ESD clamps turns on and become part of the L-C tank, causing a frequency shift. The voltage amplitude is controlled by setting the current drive value for the channel. The sensor still functions for voltage amplitudes to a minimum of 0.4 V_{PP}, but the SNR will degrade.

The oscilloscope probe has a capacitive loading effect when probing the sensor signal lines. A FET probe with low capacitance should be used to minimize the effects.

Table 4. Proximity and Capacitive Touch Sensor Properties

	Proximity Sensor	Capacitive Touch Button 1	Capacitive Touch Button 2
Sensor Frequency	5.30	5.41	5.60
Amplitude (mV)	1.22	1.44	1.42
Settling Time (us)	3.89	3.33	3.15
Current Drive Setting (mA)	0.069	0.081	0.081

Figure 7 and Figure 8 show the oscillation and startup waveforms for the proximity sensor and capacitive touch buttons. The yellow waveform corresponds to the proximity sensor while the green and magenta waveform corresponds to the capacitive touch button 1 and 2. The FDC2214 may be configured for current overdrive at the beginning of a conversion cycle, as illustrated in Figure 8. This feature can be used to reduce the startup up time of the oscillation and hence shorten the overall conversion time.

Figure 9 shows the multiplexing operation of the FDC2214 to collect the measurements from the various sensors. The proximity sensor's measurements (yellow) are significantly longer than the capacitive touch buttons measurements (green and magenta) to obtain a better signal-to-noise ratio. There is a tradeoff between sampling rate and resolution. For example, the higher the sampling rate, the lower the resolution. Proximity sensing applications require a high resolution to detect small changes in capacitance (on the order of a few femtofarads) from the baseline value (no target present). Capacitive touch buttons requirements are the opposite, in which high resolution is not necessary for a change in capacitance on the order of picofarads. The proximity sensor has a conversion time of approximately 16 ms while the capacitive touch buttons have a conversion time of approximately 400 μs.

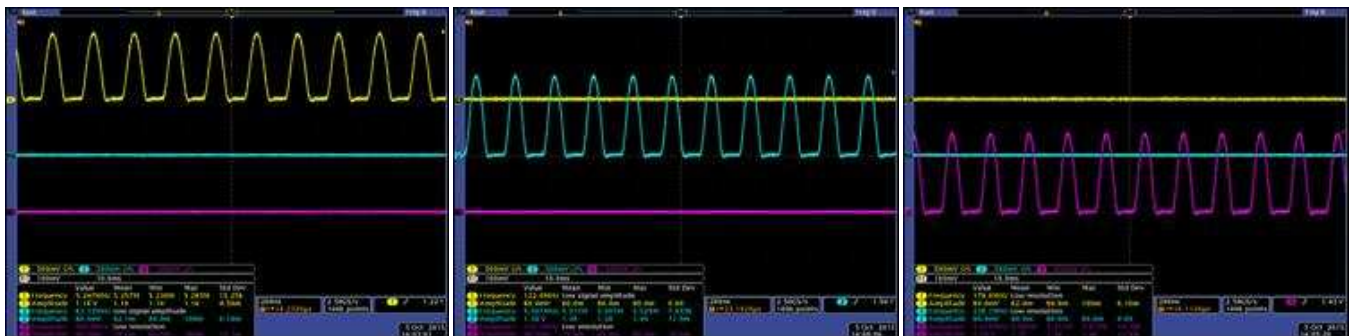

Figure 7. Proximity Sensor Waveform (Yellow), Cap Touch Button 1/2 Waveforms (Green and Magenta)



Figure 8. Proximity Startup Waveform (Yellow), Cap Touch Button 1/2 Startup Waveforms (Green, Magenta)



Figure 9. Sensor Multiplexing – Proximity (Yellow), Cap Touch Button 1 and 2 (Green, Magenta)

6 Board Layout

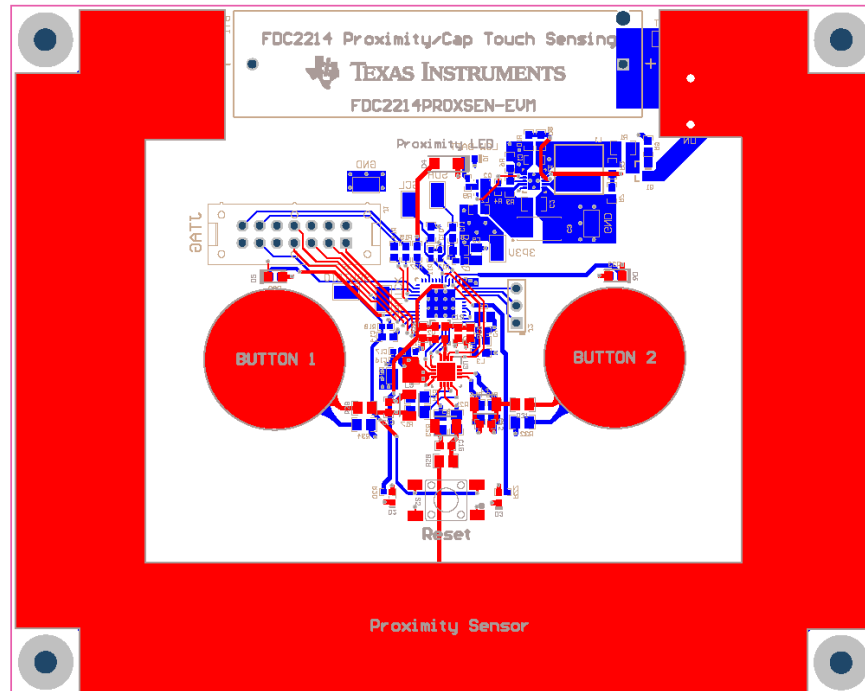

Figure 10. Composite Top and Bottom Layer Plot (Viewed From the Top)

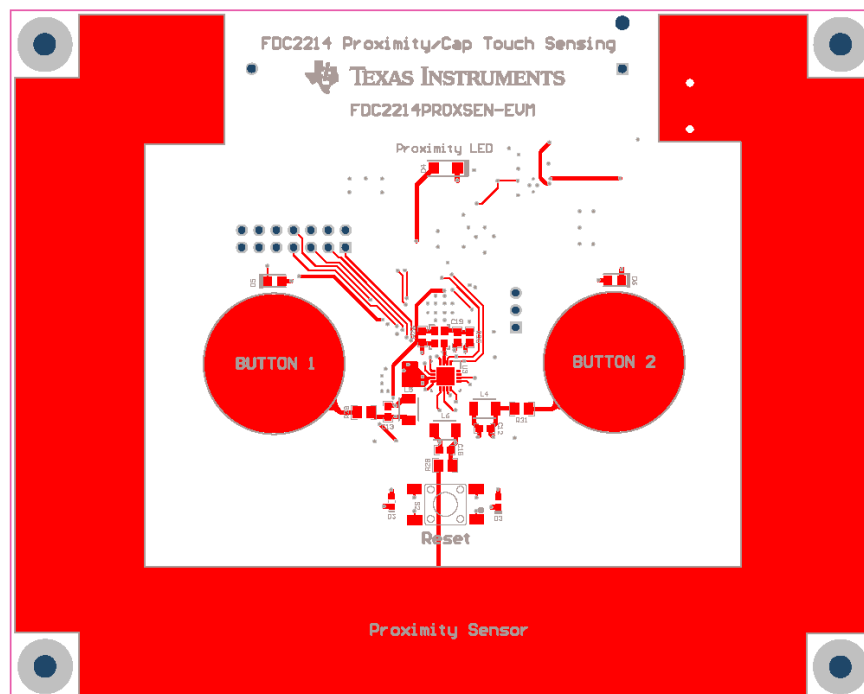

Figure 11. Top Layer

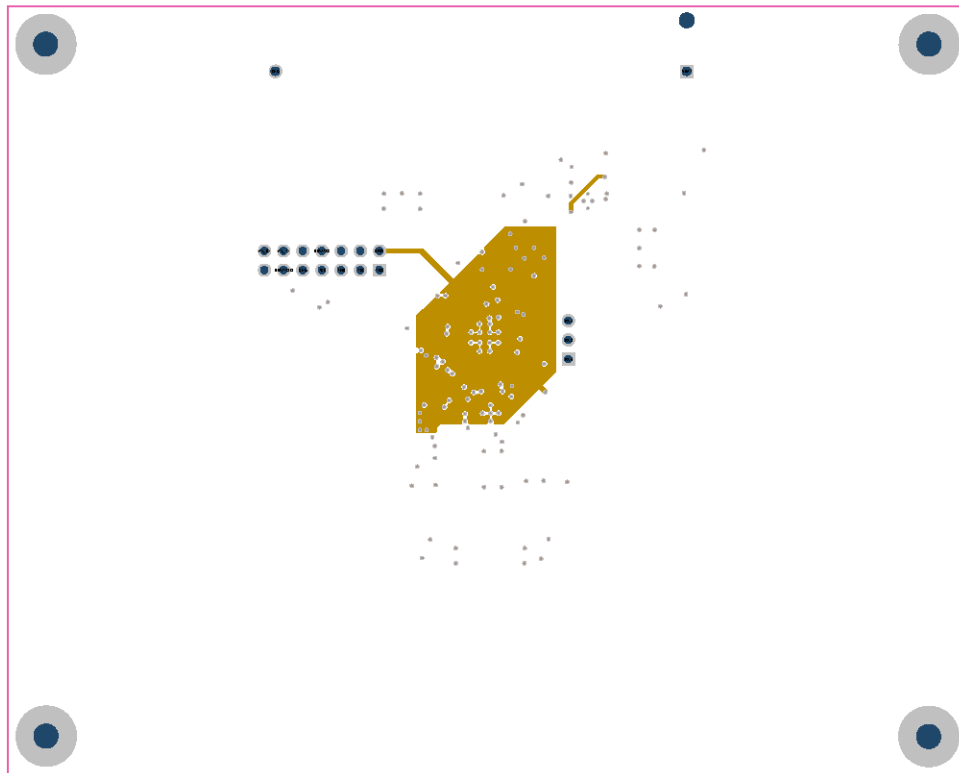

Figure 12. Midlayer 1 (Power Plane)

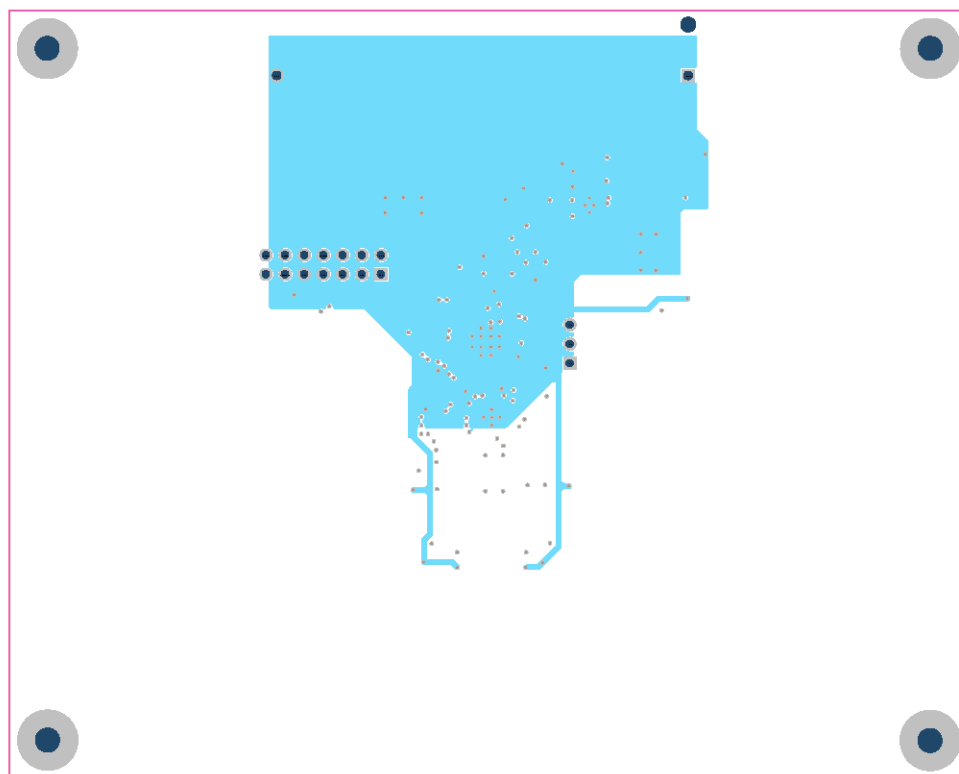

Figure 13. Midlayer 2 (GND Plane)

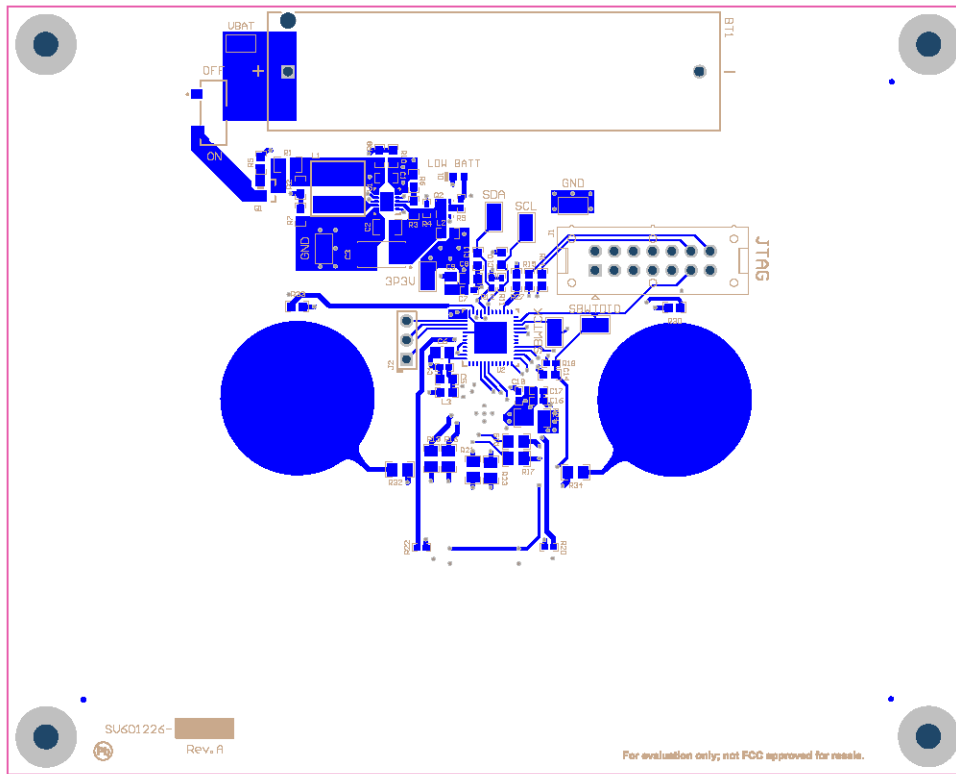

Figure 14. Bottom Layer

7 Schematic

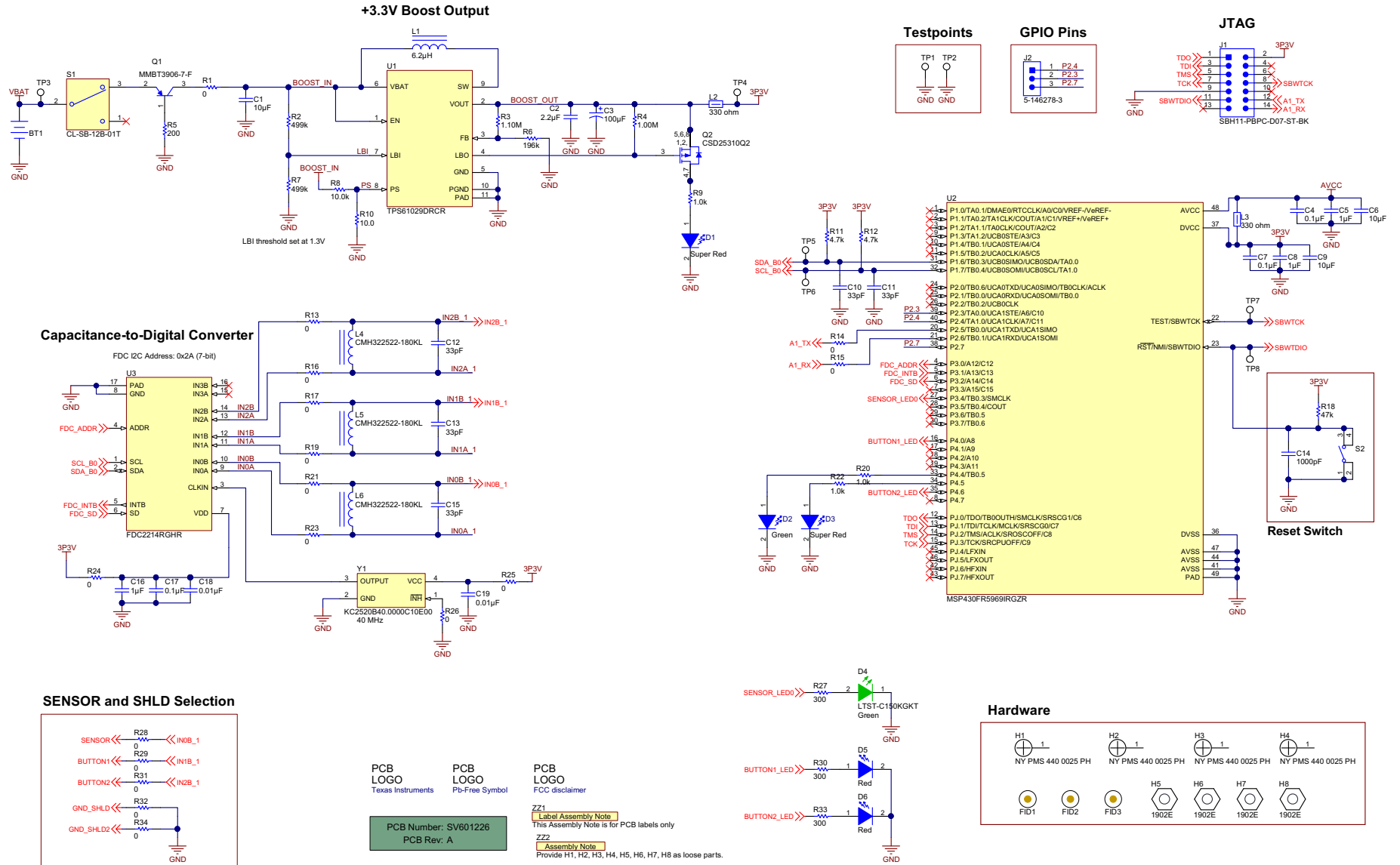

Figure 15. Schematic

STANDARD TERMS AND CONDITIONS FOR EVALUATION MODULES

1. *Delivery:* TI delivers TI evaluation boards, kits, or modules, including any accompanying demonstration software, components, or documentation (collectively, an "EVM" or "EVMs") to the User ("User") in accordance with the terms and conditions set forth herein. Acceptance of the EVM is expressly subject to the following terms and conditions.
 - 1.1 EVMs are intended solely for product or software developers for use in a research and development setting to facilitate feasibility evaluation, experimentation, or scientific analysis of TI semiconductors products. EVMs have no direct function and are not finished products. EVMs shall not be directly or indirectly assembled as a part or subassembly in any finished product. For clarification, any software or software tools provided with the EVM ("Software") shall not be subject to the terms and conditions set forth herein but rather shall be subject to the applicable terms and conditions that accompany such Software
 - 1.2 EVMs are not intended for consumer or household use. EVMs may not be sold, sublicensed, leased, rented, loaned, assigned, or otherwise distributed for commercial purposes by Users, in whole or in part, or used in any finished product or production system.
2. *Limited Warranty and Related Remedies/Disclaimers:*
 - 2.1 These terms and conditions do not apply to Software. The warranty, if any, for Software is covered in the applicable Software License Agreement.
 - 2.2 TI warrants that the TI EVM will conform to TI's published specifications for ninety (90) days after the date TI delivers such EVM to User. Notwithstanding the foregoing, TI shall not be liable for any defects that are caused by neglect, misuse or mistreatment by an entity other than TI, including improper installation or testing, or for any EVMs that have been altered or modified in any way by an entity other than TI. Moreover, TI shall not be liable for any defects that result from User's design, specifications or instructions for such EVMs. Testing and other quality control techniques are used to the extent TI deems necessary or as mandated by government requirements. TI does not test all parameters of each EVM.
 - 2.3 If any EVM fails to conform to the warranty set forth above, TI's sole liability shall be at its option to repair or replace such EVM, or credit User's account for such EVM. TI's liability under this warranty shall be limited to EVMs that are returned during the warranty period to the address designated by TI and that are determined by TI not to conform to such warranty. If TI elects to repair or replace such EVM, TI shall have a reasonable time to repair such EVM or provide replacements. Repaired EVMs shall be warranted for the remainder of the original warranty period. Replaced EVMs shall be warranted for a new full ninety (90) day warranty period.
3. *Regulatory Notices:*
 - 3.1 *United States*
 - 3.1.1 *Notice applicable to EVMs not FCC-Approved:*

This kit is designed to allow product developers to evaluate electronic components, circuitry, or software associated with the kit to determine whether to incorporate such items in a finished product and software developers to write software applications for use with the end product. This kit is not a finished product and when assembled may not be resold or otherwise marketed unless all required FCC equipment authorizations are first obtained. Operation is subject to the condition that this product not cause harmful interference to licensed radio stations and that this product accept harmful interference. Unless the assembled kit is designed to operate under part 15, part 18 or part 95 of this chapter, the operator of the kit must operate under the authority of an FCC license holder or must secure an experimental authorization under part 5 of this chapter.
 - 3.1.2 *For EVMs annotated as FCC – FEDERAL COMMUNICATIONS COMMISSION Part 15 Compliant:*

CAUTION

This device complies with part 15 of the FCC Rules. Operation is subject to the following two conditions: (1) This device may not cause harmful interference, and (2) this device must accept any interference received, including interference that may cause undesired operation.

Changes or modifications not expressly approved by the party responsible for compliance could void the user's authority to operate the equipment.

FCC Interference Statement for Class A EVM devices

NOTE: This equipment has been tested and found to comply with the limits for a Class A digital device, pursuant to part 15 of the FCC Rules. These limits are designed to provide reasonable protection against harmful interference when the equipment is operated in a commercial environment. This equipment generates, uses, and can radiate radio frequency energy and, if not installed and used in accordance with the instruction manual, may cause harmful interference to radio communications. Operation of this equipment in a residential area is likely to cause harmful interference in which case the user will be required to correct the interference at his own expense.

FCC Interference Statement for Class B EVM devices

NOTE: This equipment has been tested and found to comply with the limits for a Class B digital device, pursuant to part 15 of the FCC Rules. These limits are designed to provide reasonable protection against harmful interference in a residential installation. This equipment generates, uses and can radiate radio frequency energy and, if not installed and used in accordance with the instructions, may cause harmful interference to radio communications. However, there is no guarantee that interference will not occur in a particular installation. If this equipment does cause harmful interference to radio or television reception, which can be determined by turning the equipment off and on, the user is encouraged to try to correct the interference by one or more of the following measures:

- Reorient or relocate the receiving antenna.
- Increase the separation between the equipment and receiver.
- Connect the equipment into an outlet on a circuit different from that to which the receiver is connected.
- Consult the dealer or an experienced radio/TV technician for help.

3.2 Canada

3.2.1 For EVMs issued with an Industry Canada Certificate of Conformance to RSS-210

Concerning EVMs Including Radio Transmitters:

This device complies with Industry Canada license-exempt RSS standard(s). Operation is subject to the following two conditions: (1) this device may not cause interference, and (2) this device must accept any interference, including interference that may cause undesired operation of the device.

Concernant les EVMs avec appareils radio:

Le présent appareil est conforme aux CNR d'Industrie Canada applicables aux appareils radio exempts de licence. L'exploitation est autorisée aux deux conditions suivantes: (1) l'appareil ne doit pas produire de brouillage, et (2) l'utilisateur de l'appareil doit accepter tout brouillage radioélectrique subi, même si le brouillage est susceptible d'en compromettre le fonctionnement.

Concerning EVMs Including Detachable Antennas:

Under Industry Canada regulations, this radio transmitter may only operate using an antenna of a type and maximum (or lesser) gain approved for the transmitter by Industry Canada. To reduce potential radio interference to other users, the antenna type and its gain should be so chosen that the equivalent isotropically radiated power (e.i.r.p.) is not more than that necessary for successful communication. This radio transmitter has been approved by Industry Canada to operate with the antenna types listed in the user guide with the maximum permissible gain and required antenna impedance for each antenna type indicated. Antenna types not included in this list, having a gain greater than the maximum gain indicated for that type, are strictly prohibited for use with this device.

Concernant les EVMs avec antennes détachables

Conformément à la réglementation d'Industrie Canada, le présent émetteur radio peut fonctionner avec une antenne d'un type et d'un gain maximal (ou inférieur) approuvé pour l'émetteur par Industrie Canada. Dans le but de réduire les risques de brouillage radioélectrique à l'intention des autres utilisateurs, il faut choisir le type d'antenne et son gain de sorte que la puissance isotrope rayonnée équivalente (p.i.r.e.) ne dépasse pas l'intensité nécessaire à l'établissement d'une communication satisfaisante. Le présent émetteur radio a été approuvé par Industrie Canada pour fonctionner avec les types d'antenne énumérés dans le manuel d'usage et ayant un gain admissible maximal et l'impédance requise pour chaque type d'antenne. Les types d'antenne non inclus dans cette liste, ou dont le gain est supérieur au gain maximal indiqué, sont strictement interdits pour l'exploitation de l'émetteur.

3.3 Japan

3.3.1 *Notice for EVMs delivered in Japan:* Please see http://www.tij.co.jp/lstds/ti_ja/general/eStore/notice_01.page 日本国内に輸入される評価用キット、ボードについては、次のところをご覧ください。
http://www.tij.co.jp/lstds/ti_ja/general/eStore/notice_01.page

3.3.2 *Notice for Users of EVMs Considered "Radio Frequency Products" in Japan:* EVMs entering Japan may not be certified by TI as conforming to Technical Regulations of Radio Law of Japan.

If User uses EVMs in Japan, not certified to Technical Regulations of Radio Law of Japan, User is required by Radio Law of Japan to follow the instructions below with respect to EVMs:

1. Use EVMs in a shielded room or any other test facility as defined in the notification #173 issued by Ministry of Internal Affairs and Communications on March 28, 2006, based on Sub-section 1.1 of Article 6 of the Ministry's Rule for Enforcement of Radio Law of Japan,
2. Use EVMs only after User obtains the license of Test Radio Station as provided in Radio Law of Japan with respect to EVMs, or
3. Use of EVMs only after User obtains the Technical Regulations Conformity Certification as provided in Radio Law of Japan with respect to EVMs. Also, do not transfer EVMs, unless User gives the same notice above to the transferee. Please note that if User does not follow the instructions above, User will be subject to penalties of Radio Law of Japan.

【無線電波を送信する製品の開発キットをお使いになる際の注意事項】 開発キットの中には技術基準適合証明を受けていないものがあります。技術適合証明を受けていないもののご使用に際しては、電波法遵守のため、以下のいずれかの措置を取っていただく必要がありますのでご注意ください。

1. 電波法施行規則第6条第1項第1号に基づく平成18年3月28日総務省告示第173号で定められた電波暗室等の試験設備でご使用いただく。
2. 実験局の免許を取得後ご使用いただく。
3. 技術基準適合証明を取得後ご使用いただく。

なお、本製品は、上記の「ご使用にあたっての注意」を譲渡先、移転先に通知しない限り、譲渡、移転できないものとします。

上記を遵守頂けない場合は、電波法の罰則が適用される可能性があることをご留意ください。日本テキサス・インスツルメンツ株式会社
東京都新宿区西新宿 6 丁目 2 4 番 1 号
西新宿三井ビル

3.3.3 *Notice for EVMs for Power Line Communication:* Please see http://www.tij.co.jp/llds/ti_ja/general/eStore/notice_02.page
電力線搬送波通信についての開発キットをお使いになる際の注意事項については、次のところをご覧ください。http://www.tij.co.jp/llds/ti_ja/general/eStore/notice_02.page

4 *EVM Use Restrictions and Warnings:*

4.1 EVMS ARE NOT FOR USE IN FUNCTIONAL SAFETY AND/OR SAFETY CRITICAL EVALUATIONS, INCLUDING BUT NOT LIMITED TO EVALUATIONS OF LIFE SUPPORT APPLICATIONS.

4.2 User must read and apply the user guide and other available documentation provided by TI regarding the EVM prior to handling or using the EVM, including without limitation any warning or restriction notices. The notices contain important safety information related to, for example, temperatures and voltages.

4.3 *Safety-Related Warnings and Restrictions:*

4.3.1 User shall operate the EVM within TI's recommended specifications and environmental considerations stated in the user guide, other available documentation provided by TI, and any other applicable requirements and employ reasonable and customary safeguards. Exceeding the specified performance ratings and specifications (including but not limited to input and output voltage, current, power, and environmental ranges) for the EVM may cause personal injury or death, or property damage. If there are questions concerning performance ratings and specifications, User should contact a TI field representative prior to connecting interface electronics including input power and intended loads. Any loads applied outside of the specified output range may also result in unintended and/or inaccurate operation and/or possible permanent damage to the EVM and/or interface electronics. Please consult the EVM user guide prior to connecting any load to the EVM output. If there is uncertainty as to the load specification, please contact a TI field representative. During normal operation, even with the inputs and outputs kept within the specified allowable ranges, some circuit components may have elevated case temperatures. These components include but are not limited to linear regulators, switching transistors, pass transistors, current sense resistors, and heat sinks, which can be identified using the information in the associated documentation. When working with the EVM, please be aware that the EVM may become very warm.

4.3.2 EVMs are intended solely for use by technically qualified, professional electronics experts who are familiar with the dangers and application risks associated with handling electrical mechanical components, systems, and subsystems. User assumes all responsibility and liability for proper and safe handling and use of the EVM by User or its employees, affiliates, contractors or designees. User assumes all responsibility and liability to ensure that any interfaces (electronic and/or mechanical) between the EVM and any human body are designed with suitable isolation and means to safely limit accessible leakage currents to minimize the risk of electrical shock hazard. User assumes all responsibility and liability for any improper or unsafe handling or use of the EVM by User or its employees, affiliates, contractors or designees.

4.4 User assumes all responsibility and liability to determine whether the EVM is subject to any applicable international, federal, state, or local laws and regulations related to User's handling and use of the EVM and, if applicable, User assumes all responsibility and liability for compliance in all respects with such laws and regulations. User assumes all responsibility and liability for proper disposal and recycling of the EVM consistent with all applicable international, federal, state, and local requirements.

5. *Accuracy of Information:* To the extent TI provides information on the availability and function of EVMs, TI attempts to be as accurate as possible. However, TI does not warrant the accuracy of EVM descriptions, EVM availability or other information on its websites as accurate, complete, reliable, current, or error-free.

6. *Disclaimers:*
- 6.1 EXCEPT AS SET FORTH ABOVE, EVMS AND ANY WRITTEN DESIGN MATERIALS PROVIDED WITH THE EVM (AND THE DESIGN OF THE EVM ITSELF) ARE PROVIDED "AS IS" AND "WITH ALL FAULTS." TI DISCLAIMS ALL OTHER WARRANTIES, EXPRESS OR IMPLIED, REGARDING SUCH ITEMS, INCLUDING BUT NOT LIMITED TO ANY IMPLIED WARRANTIES OF MERCHANTABILITY OR FITNESS FOR A PARTICULAR PURPOSE OR NON-INFRINGEMENT OF ANY THIRD PARTY PATENTS, COPYRIGHTS, TRADE SECRETS OR OTHER INTELLECTUAL PROPERTY RIGHTS.
- 6.2 EXCEPT FOR THE LIMITED RIGHT TO USE THE EVM SET FORTH HEREIN, NOTHING IN THESE TERMS AND CONDITIONS SHALL BE CONSTRUED AS GRANTING OR CONFERRING ANY RIGHTS BY LICENSE, PATENT, OR ANY OTHER INDUSTRIAL OR INTELLECTUAL PROPERTY RIGHT OF TI, ITS SUPPLIERS/LICENSORS OR ANY OTHER THIRD PARTY, TO USE THE EVM IN ANY FINISHED END-USER OR READY-TO-USE FINAL PRODUCT, OR FOR ANY INVENTION, DISCOVERY OR IMPROVEMENT MADE, CONCEIVED OR ACQUIRED PRIOR TO OR AFTER DELIVERY OF THE EVM.
7. *USER'S INDEMNITY OBLIGATIONS AND REPRESENTATIONS.* USER WILL DEFEND, INDEMNIFY AND HOLD TI, ITS LICENSORS AND THEIR REPRESENTATIVES HARMLESS FROM AND AGAINST ANY AND ALL CLAIMS, DAMAGES, LOSSES, EXPENSES, COSTS AND LIABILITIES (COLLECTIVELY, "CLAIMS") ARISING OUT OF OR IN CONNECTION WITH ANY HANDLING OR USE OF THE EVM THAT IS NOT IN ACCORDANCE WITH THESE TERMS AND CONDITIONS. THIS OBLIGATION SHALL APPLY WHETHER CLAIMS ARISE UNDER STATUTE, REGULATION, OR THE LAW OF TORT, CONTRACT OR ANY OTHER LEGAL THEORY, AND EVEN IF THE EVM FAILS TO PERFORM AS DESCRIBED OR EXPECTED.
8. *Limitations on Damages and Liability:*
- 8.1 *General Limitations.* IN NO EVENT SHALL TI BE LIABLE FOR ANY SPECIAL, COLLATERAL, INDIRECT, PUNITIVE, INCIDENTAL, CONSEQUENTIAL, OR EXEMPLARY DAMAGES IN CONNECTION WITH OR ARISING OUT OF THESE TERMS AND CONDITIONS OR THE USE OF THE EVMS PROVIDED HEREUNDER, REGARDLESS OF WHETHER TI HAS BEEN ADVISED OF THE POSSIBILITY OF SUCH DAMAGES. EXCLUDED DAMAGES INCLUDE, BUT ARE NOT LIMITED TO, COST OF REMOVAL OR REINSTALLATION, ANCILLARY COSTS TO THE PROCUREMENT OF SUBSTITUTE GOODS OR SERVICES, RETESTING, OUTSIDE COMPUTER TIME, LABOR COSTS, LOSS OF GOODWILL, LOSS OF PROFITS, LOSS OF SAVINGS, LOSS OF USE, LOSS OF DATA, OR BUSINESS INTERRUPTION. NO CLAIM, SUIT OR ACTION SHALL BE BROUGHT AGAINST TI MORE THAN ONE YEAR AFTER THE RELATED CAUSE OF ACTION HAS OCCURRED.
- 8.2 *Specific Limitations.* IN NO EVENT SHALL TI'S AGGREGATE LIABILITY FROM ANY WARRANTY OR OTHER OBLIGATION ARISING OUT OF OR IN CONNECTION WITH THESE TERMS AND CONDITIONS, OR ANY USE OF ANY TI EVM PROVIDED HEREUNDER, EXCEED THE TOTAL AMOUNT PAID TO TI FOR THE PARTICULAR UNITS SOLD UNDER THESE TERMS AND CONDITIONS WITH RESPECT TO WHICH LOSSES OR DAMAGES ARE CLAIMED. THE EXISTENCE OF MORE THAN ONE CLAIM AGAINST THE PARTICULAR UNITS SOLD TO USER UNDER THESE TERMS AND CONDITIONS SHALL NOT ENLARGE OR EXTEND THIS LIMIT.
9. *Return Policy.* Except as otherwise provided, TI does not offer any refunds, returns, or exchanges. Furthermore, no return of EVM(s) will be accepted if the package has been opened and no return of the EVM(s) will be accepted if they are damaged or otherwise not in a resalable condition. If User feels it has been incorrectly charged for the EVM(s) it ordered or that delivery violates the applicable order, User should contact TI. All refunds will be made in full within thirty (30) working days from the return of the components(s), excluding any postage or packaging costs.
10. *Governing Law:* These terms and conditions shall be governed by and interpreted in accordance with the laws of the State of Texas, without reference to conflict-of-laws principles. User agrees that non-exclusive jurisdiction for any dispute arising out of or relating to these terms and conditions lies within courts located in the State of Texas and consents to venue in Dallas County, Texas. Notwithstanding the foregoing, any judgment may be enforced in any United States or foreign court, and TI may seek injunctive relief in any United States or foreign court.

Mailing Address: Texas Instruments, Post Office Box 655303, Dallas, Texas 75265
Copyright © 2015, Texas Instruments Incorporated

IMPORTANT NOTICE

Texas Instruments Incorporated and its subsidiaries (TI) reserve the right to make corrections, enhancements, improvements and other changes to its semiconductor products and services per JESD46, latest issue, and to discontinue any product or service per JESD48, latest issue. Buyers should obtain the latest relevant information before placing orders and should verify that such information is current and complete. All semiconductor products (also referred to herein as "components") are sold subject to TI's terms and conditions of sale supplied at the time of order acknowledgment.

TI warrants performance of its components to the specifications applicable at the time of sale, in accordance with the warranty in TI's terms and conditions of sale of semiconductor products. Testing and other quality control techniques are used to the extent TI deems necessary to support this warranty. Except where mandated by applicable law, testing of all parameters of each component is not necessarily performed.

TI assumes no liability for applications assistance or the design of Buyers' products. Buyers are responsible for their products and applications using TI components. To minimize the risks associated with Buyers' products and applications, Buyers should provide adequate design and operating safeguards.

TI does not warrant or represent that any license, either express or implied, is granted under any patent right, copyright, mask work right, or other intellectual property right relating to any combination, machine, or process in which TI components or services are used. Information published by TI regarding third-party products or services does not constitute a license to use such products or services or a warranty or endorsement thereof. Use of such information may require a license from a third party under the patents or other intellectual property of the third party, or a license from TI under the patents or other intellectual property of TI.

Reproduction of significant portions of TI information in TI data books or data sheets is permissible only if reproduction is without alteration and is accompanied by all associated warranties, conditions, limitations, and notices. TI is not responsible or liable for such altered documentation. Information of third parties may be subject to additional restrictions.

Resale of TI components or services with statements different from or beyond the parameters stated by TI for that component or service voids all express and any implied warranties for the associated TI component or service and is an unfair and deceptive business practice. TI is not responsible or liable for any such statements.

Buyer acknowledges and agrees that it is solely responsible for compliance with all legal, regulatory and safety-related requirements concerning its products, and any use of TI components in its applications, notwithstanding any applications-related information or support that may be provided by TI. Buyer represents and agrees that it has all the necessary expertise to create and implement safeguards which anticipate dangerous consequences of failures, monitor failures and their consequences, lessen the likelihood of failures that might cause harm and take appropriate remedial actions. Buyer will fully indemnify TI and its representatives against any damages arising out of the use of any TI components in safety-critical applications.

In some cases, TI components may be promoted specifically to facilitate safety-related applications. With such components, TI's goal is to help enable customers to design and create their own end-product solutions that meet applicable functional safety standards and requirements. Nonetheless, such components are subject to these terms.

No TI components are authorized for use in FDA Class III (or similar life-critical medical equipment) unless authorized officers of the parties have executed a special agreement specifically governing such use.

Only those TI components which TI has specifically designated as military grade or "enhanced plastic" are designed and intended for use in military/aerospace applications or environments. Buyer acknowledges and agrees that any military or aerospace use of TI components which have **not** been so designated is solely at the Buyer's risk, and that Buyer is solely responsible for compliance with all legal and regulatory requirements in connection with such use.

TI has specifically designated certain components as meeting ISO/TS16949 requirements, mainly for automotive use. In any case of use of non-designated products, TI will not be responsible for any failure to meet ISO/TS16949.

Products

Audio	www.ti.com/audio
Amplifiers	amplifier.ti.com
Data Converters	dataconverter.ti.com
DLP® Products	www.dlp.com
DSP	dsp.ti.com
Clocks and Timers	www.ti.com/clocks
Interface	interface.ti.com
Logic	logic.ti.com
Power Mgmt	power.ti.com
Microcontrollers	microcontroller.ti.com
RFID	www.ti-rfid.com
OMAP Applications Processors	www.ti.com/omap
Wireless Connectivity	www.ti.com/wirelessconnectivity

Applications

Automotive and Transportation	www.ti.com/automotive
Communications and Telecom	www.ti.com/communications
Computers and Peripherals	www.ti.com/computers
Consumer Electronics	www.ti.com/consumer-apps
Energy and Lighting	www.ti.com/energy
Industrial	www.ti.com/industrial
Medical	www.ti.com/medical
Security	www.ti.com/security
Space, Avionics and Defense	www.ti.com/space-avionics-defense
Video and Imaging	www.ti.com/video

TI E2E Community

e2e.ti.com