

# 54ACT16652, 74ACT16652 16-BIT TRANSCEIVERS AND REGISTERS WITH 3-STATE OUTPUTS

SCAS128C – MARCH 1990 – REVISED APRIL 1996

- Members of the Texas Instruments *Widebus™* Family
- Inputs Are TTL-Voltage Compatible
- Independent Registers and Enables for A and B Buses
- Multiplexed Real-Time and Stored Data
- Flow-Through Architecture Optimizes PCB Layout
- Distributed  $V_{CC}$  and GND Pin Configuration Minimizes High-Speed Switching Noise
- *EPIC™* (Enhanced-Performance Implanted CMOS) 1- $\mu$ m Process
- 500-mA Typical Latch-Up Immunity at 125°C
- Package Options Include Plastic 300-mil Shrink Small-Outline (DL) Packages Using 25-mil Center-to-Center Pin Spacings and 380-mil Fine-Pitch Ceramic Flat (WD) Packages Using 25-mil Center-to-Center Spacings

## description

The 'ACT16652 are 16-bit bus transceivers consisting of D-type flip-flops and control circuitry arranged for multiplexed transmission of data directly from the data bus or from the internal storage registers. The devices can be used as two 8-bit transceivers or one 16-bit transceiver.

Complementary output-enable (OEAB and  $\overline{OEBA}$ ) inputs are provided to control the transceiver functions. Select-control (SAB and SBA) inputs are provided to select whether real-time or stored data is transferred. A low input level selects real-time data, and a high input level selects stored data. The circuitry used for select control eliminates the typical decoding glitch that occurs in a multiplexer during the transition between stored and real-time data. Figure 1 illustrates the four fundamental bus-management functions that can be performed with the 'ACT16652.

54ACT16652 . . . WD PACKAGE  
74ACT16652 . . . DL PACKAGE  
(TOP VIEW)

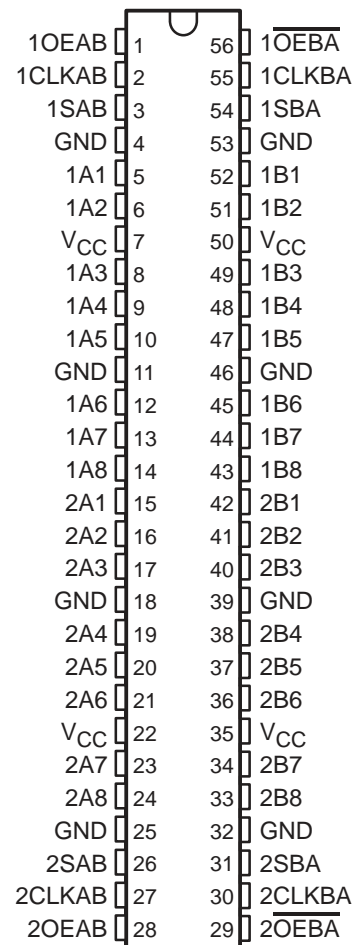

Please be aware that an important notice concerning availability, standard warranty, and use in critical applications of Texas Instruments semiconductor products and disclaimers thereto appears at the end of this data sheet.

EPIC and Widebus are trademarks of Texas Instruments Incorporated.

UNLESS OTHERWISE NOTED this document contains PRODUCTION DATA information current as of publication date. Products conform to specifications per the terms of Texas Instruments standard warranty. Production processing does not necessarily include testing of all parameters.

 **TEXAS  
INSTRUMENTS**

POST OFFICE BOX 655303 • DALLAS, TEXAS 75265

Copyright © 1996, Texas Instruments Incorporated

**54ACT16652, 74ACT16652**  
**16-BIT TRANSCEIVERS AND REGISTERS**  
**WITH 3-STATE OUTPUTS**

SCAS128C – MARCH 1990 – REVISED APRIL 1996

**description (continued)**

Data on the A or B bus, or both, can be stored in the internal D flip-flops by low-to-high transitions at the appropriate clock (CLKAB or CLKBA) inputs, regardless of the levels on the select-control or output-enable inputs. When SAB and SBA are in the real-time transfer mode, it is also possible to store data without using the internal D-type flip-flops by simultaneously enabling OEAB and OEBA. In this configuration, each output reinforces its input. Thus, when all other data sources to the two sets of bus lines are at high impedance, each set of bus lines remains at its last state.

The 74ACT16652 is packaged in TI's shrink small-outline package, which provides twice the I/O pin count and functionality of standard small-outline packages in the same printed-circuit-board area.

The 54ACT16652 is characterized for operation over the full military temperature range of -55°C to 125°C. The 74ACT16652 is characterized for operation from -40°C to 85°C.

**FUNCTION TABLE**

INPUTS						DATA I/O†		OPERATION OR FUNCTION
OEAB	OEBA	CLKAB	CLKBA	SAB	SBA	A1-A8	B1-B8	
L	H	L	L	X	X	Input	Input	Isolation
L	H	↑	↑	X	X	Input	Input	Store A and B data
X	H	↑	L	X	X	Input	Unspecified‡	Store A, hold B
H	H	↑	↑	X‡	X	Input	Output	Store A in both registers
L	X	L	↑	X	X	Unspecified‡	Input	Hold A, store B
L	L	↑	↑	X	X‡	Output	Input	Store B in both registers
L	L	X	X	X	L	Output	Input	Real-time B data to A bus
L	L	X	L	X	H	Output	Input	Stored B data to A bus
H	H	X	X	L	X	Input	Output	Real-time A data to B bus
H	H	L	X	H	X	Input	Output	Stored A data to B bus
H	L	L	L	H	H	Output	Output	Stored A data to B bus and stored B data to A bus

† The data-output functions may be enabled or disabled by a variety of level combinations at OEAB or OEBA. Data-input functions are always enabled; i.e., data at the bus terminals is stored on every low-to-high transition of the clock inputs.

‡ Select control = L; clocks can occur simultaneously.

Select control = H; clocks must be staggered to load both registers.



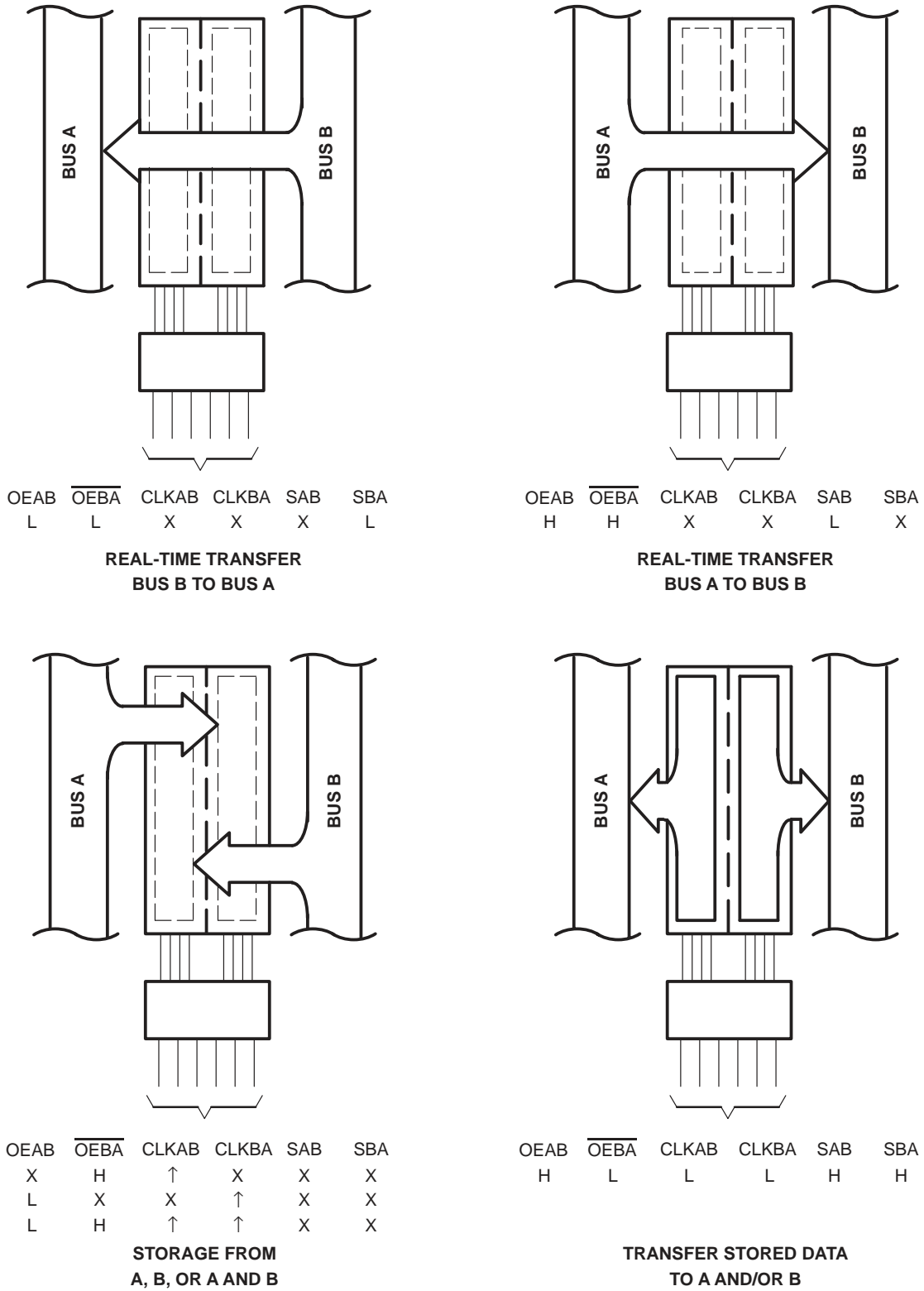
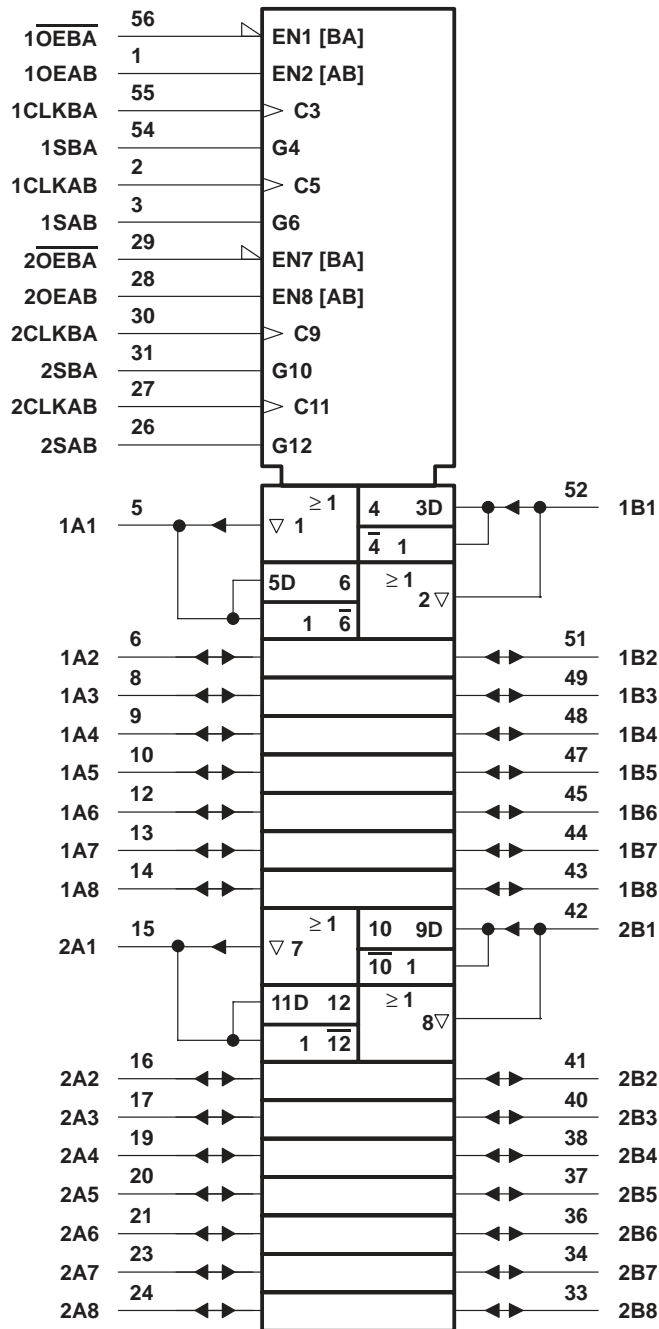

Figure 1. Bus-Management Functions

# 54ACT16652, 74ACT16652 16-BIT TRANSCEIVERS AND REGISTERS WITH 3-STATE OUTPUTS

SCAS128C – MARCH 1990 – REVISED APRIL 1996

## logic symbol†



† This symbol is in accordance with ANSI/IEEE Std 91-1984 and IEC Publication 617-12.

54ACT16652, 74ACT16652  
 16-BIT TRANSCEIVERS AND REGISTERS  
 WITH 3-STATE OUTPUTS

SCAS128C – MARCH 1990 – REVISED APRIL 1996

logic diagram (positive logic)

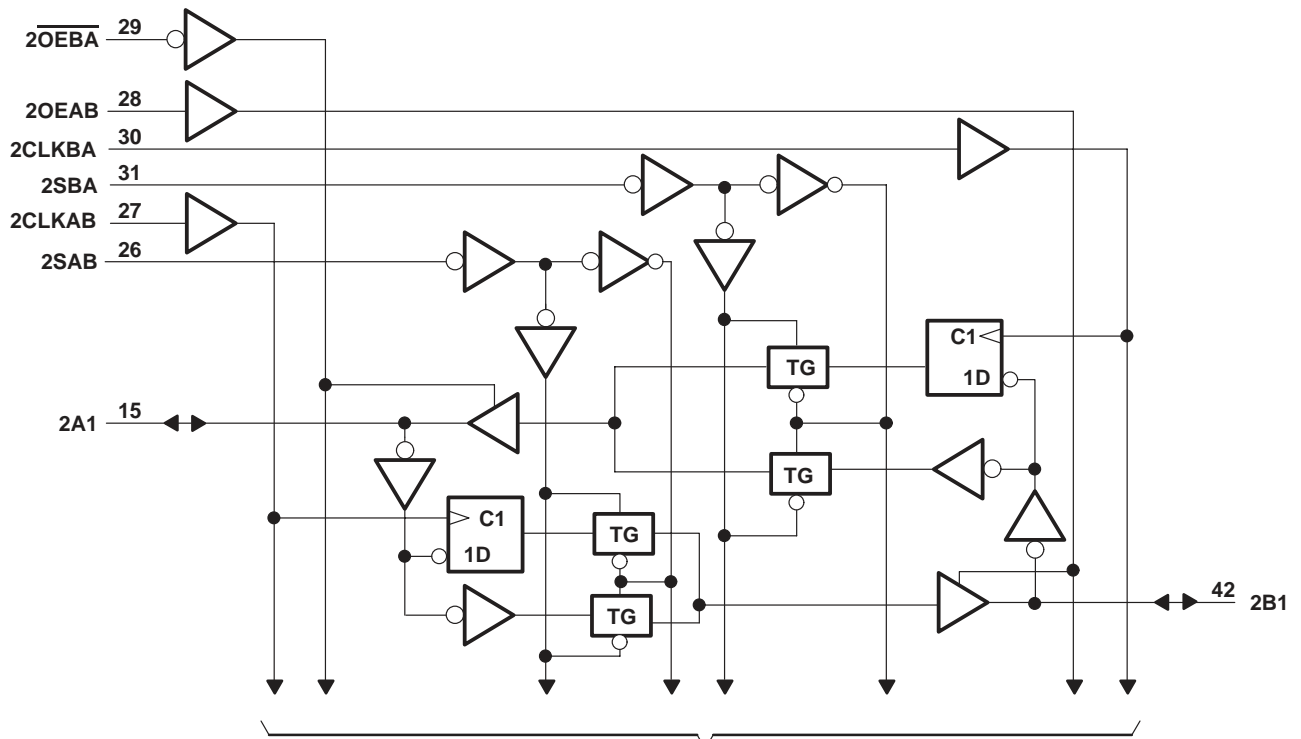
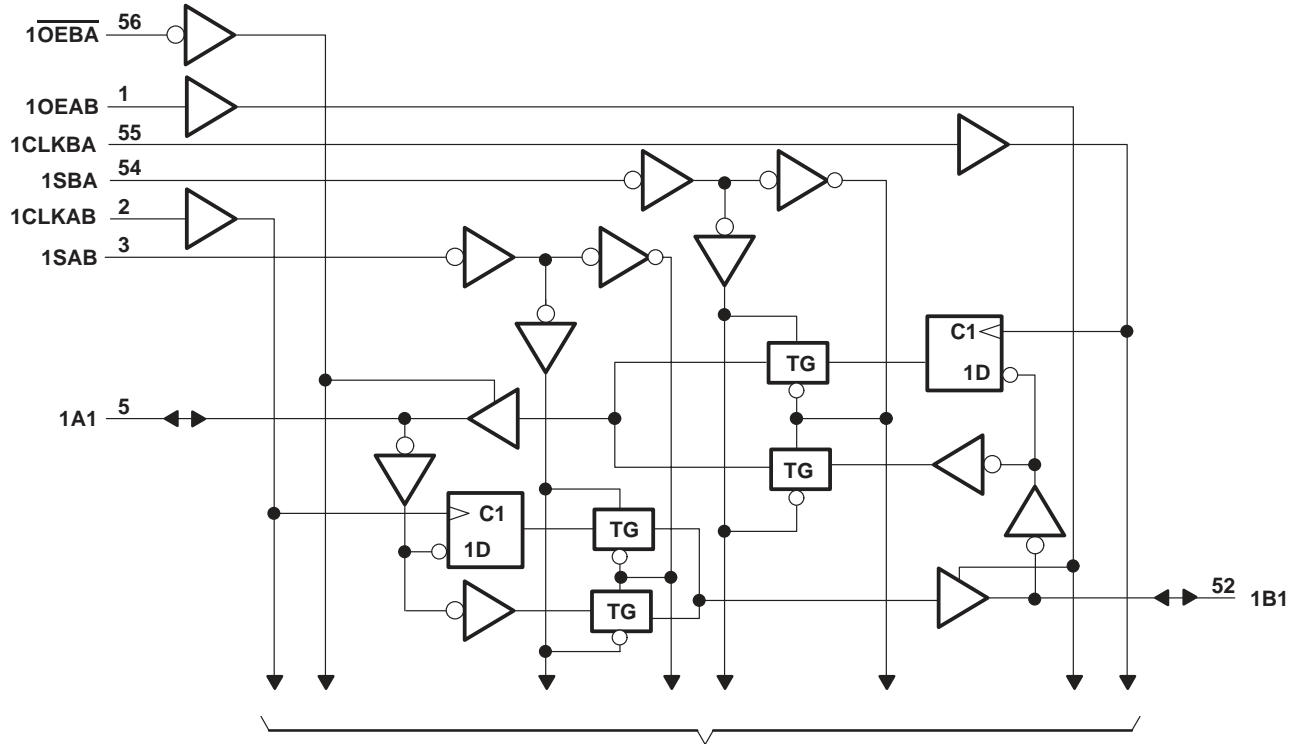

# 54ACT16652, 74ACT16652 16-BIT TRANSCEIVERS AND REGISTERS WITH 3-STATE OUTPUTS

SCAS128C – MARCH 1990 – REVISED APRIL 1996

## absolute maximum ratings over operating free-air temperature range (unless otherwise noted)†

Supply voltage range, $V_{CC}$	-0.5 V to 7 V
Input voltage range, $V_I$ (see Note 1)	-0.5 V to $V_{CC} + 0.5$ V
Output voltage range, $V_O$ (see Note 1)	-0.5 V to $V_{CC} + 0.5$ V
Input clamp current, $I_{IK}$ ( $V_I < 0$ or $V_I > V_{CC}$ )	$\pm 20$ mA
Output clamp current, $I_{OK}$ ( $V_O < 0$ or $V_O > V_{CC}$ )	$\pm 50$ mA
Continuous output current, $I_O$ ( $V_O = 0$ to $V_{CC}$ )	$\pm 50$ mA
Continuous current through $V_{CC}$ or GND	$\pm 400$ mA
Maximum package power dissipation at $T_A = 55^\circ\text{C}$ (in still air) (see Note 2): DL package	1.4 W
Storage temperature range, $T_{stg}$	$-65^\circ\text{C}$ to $150^\circ\text{C}$

† Stresses beyond those listed under “absolute maximum ratings” may cause permanent damage to the device. These are stress ratings only, and functional operation of the device at these or any other conditions beyond those indicated under “recommended operating conditions” is not implied. Exposure to absolute-maximum-rated conditions for extended periods may affect device reliability.

- NOTES: 1. The input and output voltage ratings may be exceeded if the input and output current ratings are observed.  
2. The maximum package power dissipation is calculated using a junction temperature of  $150^\circ\text{C}$  and a board trace length of 750 mils.

## recommended operating conditions (see Note 3)

	54ACT16652			74ACT16652			UNIT
	MIN	NOM	MAX	MIN	NOM	MAX	
$V_{CC}$ Supply voltage	4.5	5	5.5	4.5	5	5.5	V
$V_{IH}$ High-level input voltage	2			2			V
$V_{IL}$ Low-level input voltage			0.8			0.8	V
$V_I$ Input voltage	0		$V_{CC}$	0		$V_{CC}$	V
$V_O$ Output voltage	0		$V_{CC}$	0		$V_{CC}$	V
$I_{OH}$ High-level output current			-24			-24	mA
$I_{OL}$ Low-level output current			24			24	mA
$\Delta t/\Delta v$ Input transition rise or fall rate	0		10	0		10	ns/V
$T_A$ Operating free-air temperature	-55		125	-40		85	$^\circ\text{C}$

NOTE 3: Unused pins (input or I/O) must be held high or low to prevent them from floating.

**54ACT16652, 74ACT16652**  
**16-BIT TRANSCEIVERS AND REGISTERS**  
**WITH 3-STATE OUTPUTS**

SCAS128C – MARCH 1990 – REVISED APRIL 1996

**electrical characteristics over recommended operating free-air temperature range (unless otherwise noted)**

PARAMETER	TEST CONDITIONS	V <sub>CC</sub>	T <sub>A</sub> = 25°C			54ACT16652		74ACT16652		UNIT
			MIN	TYP	MAX	MIN	MAX	MIN	MAX	
V <sub>OH</sub>	I <sub>OH</sub> = -50 μA	4.5 V	4.4			4.4		4.4	V	
		5.5 V	5.4			5.4		5.4		
	I <sub>OH</sub> = -24 mA	4.5 V	3.94			3.8		3.8		
		5.5 V	4.94			4.8		4.8		
	I <sub>OH</sub> = -75 mA <sup>†</sup>	5.5 V				3.85		3.85		
V <sub>OL</sub>	I <sub>OL</sub> = 50 μA	4.5 V			0.1		0.1	0.1	V	
		5.5 V			0.1		0.1	0.1		
	I <sub>OL</sub> = 24 mA	4.5 V			0.36		0.44	0.44		
		5.5 V			0.36		0.44	0.44		
	I <sub>OL</sub> = 75 mA <sup>†</sup>	5.5 V				1.65		1.65		
I <sub>I</sub>	Control inputs	V <sub>I</sub> = V <sub>CC</sub> or GND	5.5 V			±0.1		±1	μA	
I <sub>OZ</sub> <sup>‡</sup>	A or B ports	V <sub>O</sub> = V <sub>CC</sub> or GND	5.5 V			±0.5		±5	μA	
I <sub>CC</sub>		V <sub>I</sub> = V <sub>CC</sub> or GND, I <sub>O</sub> = 0	5.5 V			8		80	μA	
ΔI <sub>CC</sub> <sup>§</sup>		One input at 3.4 V, Other inputs at V <sub>CC</sub> or GND	5.5 V			0.9		1	mA	
C <sub>i</sub>	Control inputs	V <sub>I</sub> = V <sub>CC</sub> or GND	5 V			4			pF	
C <sub>io</sub>	A or B ports	V <sub>O</sub> = V <sub>CC</sub> or GND	5 V			12			pF	

<sup>†</sup> Not more than one output should be tested at a time, and the duration of the test should not exceed 10 ms.

<sup>‡</sup> For I/O ports, the parameter I<sub>OZ</sub> includes the input leakage current.

<sup>§</sup> This is the increase in supply current for each input that is at one of the specified TTL voltage levels rather than 0 V or V<sub>CC</sub>.

**timing requirements over recommended operating free-air temperature range, V<sub>CC</sub> = 5 V ± 0.5 V (unless otherwise noted) (see Figure 1)**

		T <sub>A</sub> = 25°C		54ACT16652		74ACT16652		UNIT
		MIN	MAX	MIN	MAX	MIN	MAX	
f <sub>clock</sub>	Clock frequency	0	90	0	90	0	90	MHz
t <sub>w</sub>	Pulse duration, CLKAB or CLKBA high or low	5.5		5.5		5.5		ns
t <sub>su</sub>	Setup time, A before CLKAB <sup>↑</sup> or B before CLKBA <sup>↑</sup>	4.5		4.5		4.5		ns
t <sub>h</sub>	Hold time, A after CLKAB <sup>↑</sup> or B after CLKBA <sup>↑</sup>	1		1		1		ns

PRODUCT PREVIEW information concerns products in the formative or design phase of development. Characteristic data and other specifications are design goals. Texas Instruments reserves the right to change or discontinue these products without notice.



POST OFFICE BOX 655303 • DALLAS, TEXAS 75265

**54ACT16652, 74ACT16652**  
**16-BIT TRANSCEIVERS AND REGISTERS**  
**WITH 3-STATE OUTPUTS**

SCAS128C – MARCH 1990 – REVISED APRIL 1996

**switching characteristics over recommended operating free-air temperature range,  
 $V_{CC} = 5\text{ V} \pm 0.5\text{ V}$  (unless otherwise noted) (see Figure 2)**

PARAMETER	FROM (INPUT)	TO (OUTPUT)	$T_A = 25^\circ\text{C}$			54ACT16652		74ACT16652		UNIT
			MIN	TYP	MAX	MIN	MAX	MIN	MAX	
$f_{\text{max}}$			90			90		90		MHz
$t_{\text{PLH}}$	A or B	B or A	3.7	7.2	9.4	3.7	10.5	3.7	10.5	ns
$t_{\text{PHL}}$			3	8.1	10.5	3	11.6	3	11.6	
$t_{\text{PLH}}$	CLKBA or CLKAB	A or B	4.5	8.7	11.2	4.5	12.3	4.5	12.3	ns
$t_{\text{PHL}}$			4.9	8.9	11.3	4.9	12.3	4.9	12.3	
$t_{\text{PLH}}$	SBA or SAB (with A or B high)	A or B	4.9	10.4	14.1	4.9	16	4.9	16	ns
$t_{\text{PHL}}$			4.6	8.4	10.6	4.6	11.7	4.6	11.7	
$t_{\text{PLH}}$	SBA or SAB (with A or B low)	A or B	3.9	7.8	10	3.9	11.2	3.9	11.2	ns
$t_{\text{PHL}}$			5.6	12.3	14.9	5.6	16.9	5.6	16.9	
$t_{\text{PZH}}$	$\overline{\text{OEBA}}$	A	3	8.1	10.5	3	11.7	3	11.7	ns
$t_{\text{PZL}}$			3.9	9.4	12	3.9	13.4	3.9	13.4	
$t_{\text{PHZ}}$	$\overline{\text{OEBA}}$	A	5.3	7.4	8.9	5.3	9.5	5.3	9.5	ns
$t_{\text{PLZ}}$			4.8	6.8	8.6	4.8	9.2	4.8	9.2	
$t_{\text{PZH}}$	OEAB	B	4.1	7.7	9.8	4.1	10.8	4.1	10.8	ns
$t_{\text{PZL}}$			5	9	11	5	12.4	5	12.4	
$t_{\text{PHZ}}$	OEAB	B	4.4	8.1	10.1	4.4	10.5	4.4	10.5	ns
$t_{\text{PLZ}}$			4.3	7.7	9.7	4.3	9.9	4.3	9.9	

**operating characteristics,  $V_{CC} = 5\text{ V}$ ,  $T_A = 25^\circ\text{C}$**

PARAMETER		TEST CONDITIONS	TYP	UNIT
$C_{\text{pd}}$	Power dissipation capacitance per transceiver	Outputs enabled	57	pF
		Outputs disabled	13	

PRODUCT PREVIEW information concerns products in the formative or design phase of development. Characteristic data and other specifications are design goals. Texas Instruments reserves the right to change or discontinue these products without notice.



POST OFFICE BOX 655303 • DALLAS, TEXAS 75265



PARAMETER MEASUREMENT INFORMATION

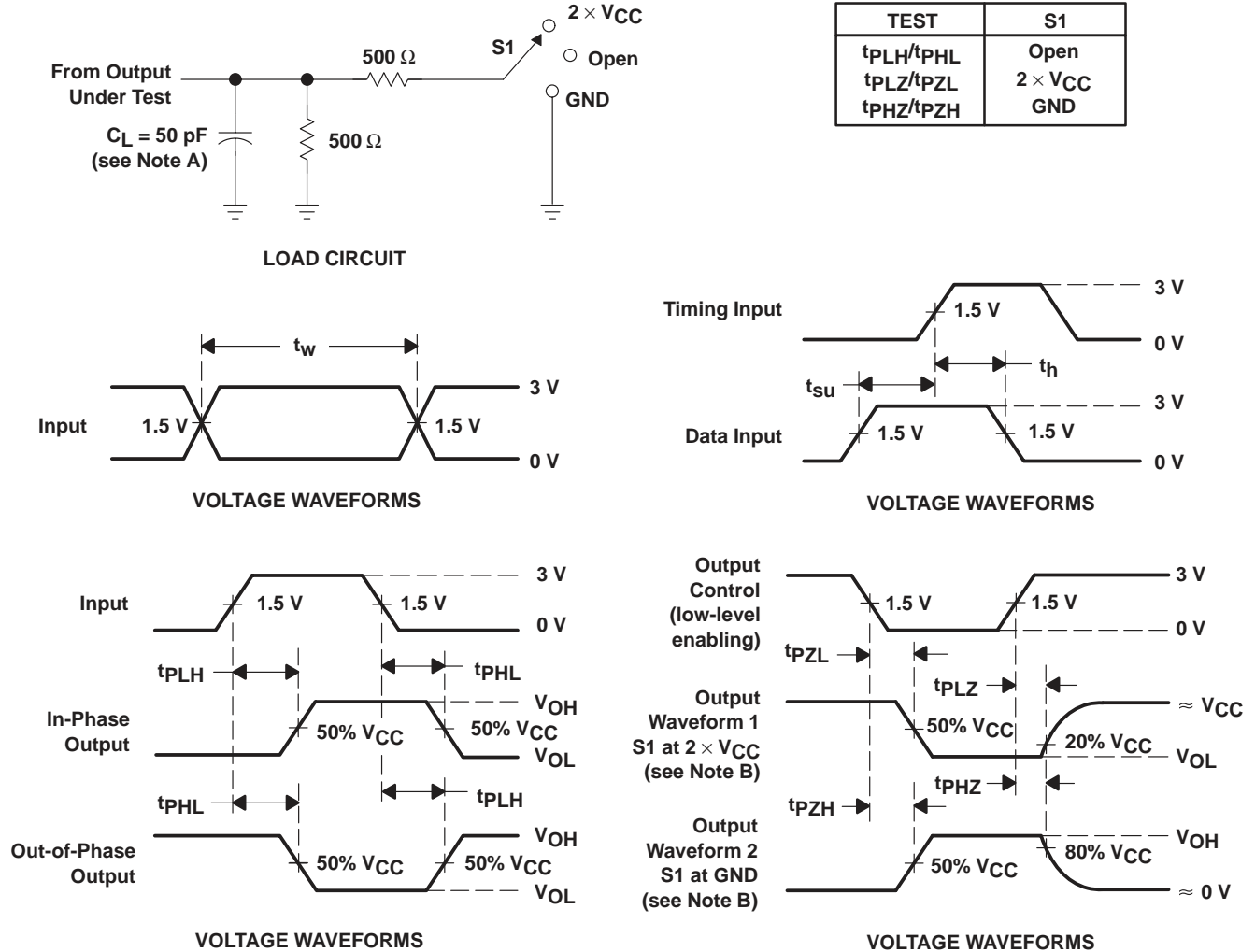

- NOTES: A.  $C_L$  includes probe and jig capacitance.  
 B. Waveform 1 is for an output with internal conditions such that the output is low except when disabled by the output control. Waveform 2 is for an output with internal conditions such that the output is high except when disabled by the output control.  
 C. All input pulses are supplied by generators having the following characteristics:  $PRR \leq 1 \text{ MHz}$ ,  $Z_O = 50 \Omega$ ,  $t_r = 3 \text{ ns}$ ,  $t_f = 3 \text{ ns}$ .  
 D. The outputs are measured one at a time with one input transition per measurement.

Figure 2. Load Circuit and Voltage Waveforms

**PACKAGING INFORMATION**

Orderable Device	Status <sup>(1)</sup>	Package Type	Package Drawing	Pins	Package Qty	Eco Plan <sup>(2)</sup>	Lead/Ball Finish	MSL Peak Temp <sup>(3)</sup>
74ACT16652DL	ACTIVE	SSOP	DL	56	20	Green (RoHS & no Sb/Br)	CU NIPDAU	Level-1-260C-UNLIM
74ACT16652DLG4	ACTIVE	SSOP	DL	56	20	Green (RoHS & no Sb/Br)	CU NIPDAU	Level-1-260C-UNLIM
74ACT16652DLR	ACTIVE	SSOP	DL	56	1000	Green (RoHS & no Sb/Br)	CU NIPDAU	Level-1-260C-UNLIM
74ACT16652DLRG4	ACTIVE	SSOP	DL	56	1000	Green (RoHS & no Sb/Br)	CU NIPDAU	Level-1-260C-UNLIM

<sup>(1)</sup> The marketing status values are defined as follows:

**ACTIVE:** Product device recommended for new designs.

**LIFEBUY:** TI has announced that the device will be discontinued, and a lifetime-buy period is in effect.

**NRND:** Not recommended for new designs. Device is in production to support existing customers, but TI does not recommend using this part in a new design.

**PREVIEW:** Device has been announced but is not in production. Samples may or may not be available.

**OBSOLETE:** TI has discontinued the production of the device.

<sup>(2)</sup> Eco Plan - The planned eco-friendly classification: Pb-Free (RoHS) or Green (RoHS & no Sb/Br) - please check <http://www.ti.com/productcontent> for the latest availability information and additional product content details.

**TBD:** The Pb-Free/Green conversion plan has not been defined.

**Pb-Free (RoHS):** TI's terms "Lead-Free" or "Pb-Free" mean semiconductor products that are compatible with the current RoHS requirements for all 6 substances, including the requirement that lead not exceed 0.1% by weight in homogeneous materials. Where designed to be soldered at high temperatures, TI Pb-Free products are suitable for use in specified lead-free processes.

**Green (RoHS & no Sb/Br):** TI defines "Green" to mean Pb-Free (RoHS compatible), and free of Bromine (Br) and Antimony (Sb) based flame retardants (Br or Sb do not exceed 0.1% by weight in homogeneous material)

<sup>(3)</sup> MSL, Peak Temp. -- The Moisture Sensitivity Level rating according to the JEDEC industry standard classifications, and peak solder temperature.

**Important Information and Disclaimer:**The information provided on this page represents TI's knowledge and belief as of the date that it is provided. TI bases its knowledge and belief on information provided by third parties, and makes no representation or warranty as to the accuracy of such information. Efforts are underway to better integrate information from third parties. TI has taken and continues to take reasonable steps to provide representative and accurate information but may not have conducted destructive testing or chemical analysis on incoming materials and chemicals. TI and TI suppliers consider certain information to be proprietary, and thus CAS numbers and other limited information may not be available for release.

In no event shall TI's liability arising out of such information exceed the total purchase price of the TI part(s) at issue in this document sold by TI to Customer on an annual basis.

**TAPE AND REEL INFORMATION**

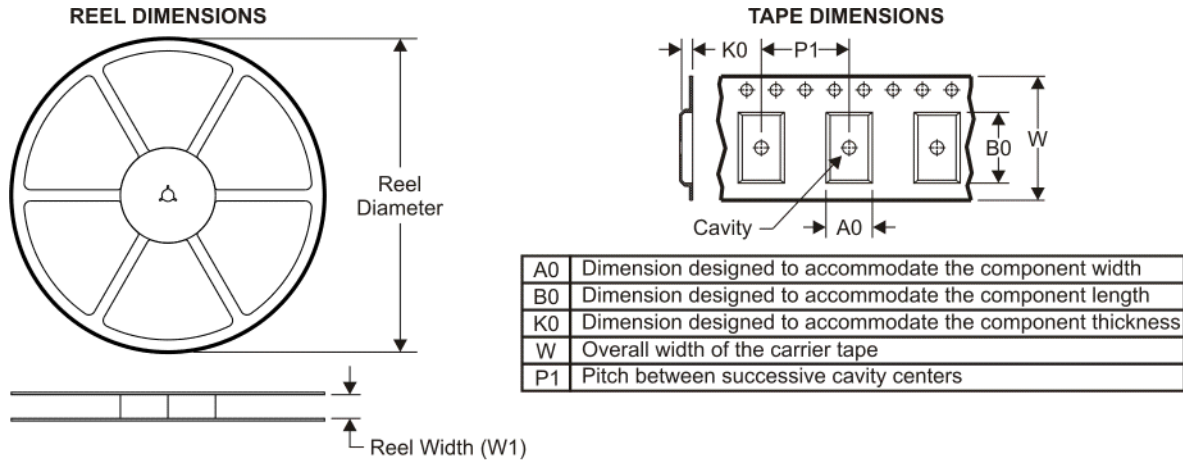

**QUADRANT ASSIGNMENTS FOR PIN 1 ORIENTATION IN TAPE**

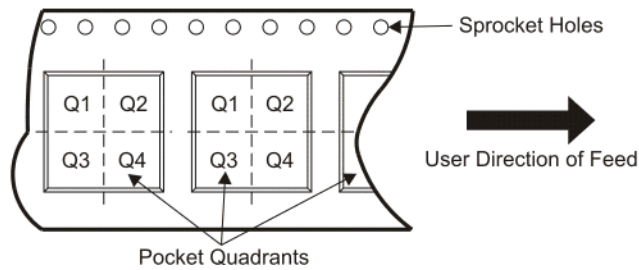

\*All dimensions are nominal

Device	Package Type	Package Drawing	Pins	SPQ	Reel Diameter (mm)	Reel Width W1 (mm)	A0 (mm)	B0 (mm)	K0 (mm)	P1 (mm)	W (mm)	Pin1 Quadrant
74ACT16652DLR	SSOP	DL	56	1000	330.0	32.4	11.35	18.67	3.1	16.0	32.0	Q1

**TAPE AND REEL BOX DIMENSIONS**



\*All dimensions are nominal

Device	Package Type	Package Drawing	Pins	SPQ	Length (mm)	Width (mm)	Height (mm)
74ACT16652DLR	SSOP	DL	56	1000	346.0	346.0	49.0

## IMPORTANT NOTICE

Texas Instruments Incorporated and its subsidiaries (TI) reserve the right to make corrections, modifications, enhancements, improvements, and other changes to its products and services at any time and to discontinue any product or service without notice. Customers should obtain the latest relevant information before placing orders and should verify that such information is current and complete. All products are sold subject to TI's terms and conditions of sale supplied at the time of order acknowledgment.

TI warrants performance of its hardware products to the specifications applicable at the time of sale in accordance with TI's standard warranty. Testing and other quality control techniques are used to the extent TI deems necessary to support this warranty. Except where mandated by government requirements, testing of all parameters of each product is not necessarily performed.

TI assumes no liability for applications assistance or customer product design. Customers are responsible for their products and applications using TI components. To minimize the risks associated with customer products and applications, customers should provide adequate design and operating safeguards.

TI does not warrant or represent that any license, either express or implied, is granted under any TI patent right, copyright, mask work right, or other TI intellectual property right relating to any combination, machine, or process in which TI products or services are used. Information published by TI regarding third-party products or services does not constitute a license from TI to use such products or services or a warranty or endorsement thereof. Use of such information may require a license from a third party under the patents or other intellectual property of the third party, or a license from TI under the patents or other intellectual property of TI.

Reproduction of TI information in TI data books or data sheets is permissible only if reproduction is without alteration and is accompanied by all associated warranties, conditions, limitations, and notices. Reproduction of this information with alteration is an unfair and deceptive business practice. TI is not responsible or liable for such altered documentation. Information of third parties may be subject to additional restrictions.

Resale of TI products or services with statements different from or beyond the parameters stated by TI for that product or service voids all express and any implied warranties for the associated TI product or service and is an unfair and deceptive business practice. TI is not responsible or liable for any such statements.

TI products are not authorized for use in safety-critical applications (such as life support) where a failure of the TI product would reasonably be expected to cause severe personal injury or death, unless officers of the parties have executed an agreement specifically governing such use. Buyers represent that they have all necessary expertise in the safety and regulatory ramifications of their applications, and acknowledge and agree that they are solely responsible for all legal, regulatory and safety-related requirements concerning their products and any use of TI products in such safety-critical applications, notwithstanding any applications-related information or support that may be provided by TI. Further, Buyers must fully indemnify TI and its representatives against any damages arising out of the use of TI products in such safety-critical applications.

TI products are neither designed nor intended for use in military/aerospace applications or environments unless the TI products are specifically designated by TI as military-grade or "enhanced plastic." Only products designated by TI as military-grade meet military specifications. Buyers acknowledge and agree that any such use of TI products which TI has not designated as military-grade is solely at the Buyer's risk, and that they are solely responsible for compliance with all legal and regulatory requirements in connection with such use.

TI products are neither designed nor intended for use in automotive applications or environments unless the specific TI products are designated by TI as compliant with ISO/TS 16949 requirements. Buyers acknowledge and agree that, if they use any non-designated products in automotive applications, TI will not be responsible for any failure to meet such requirements.

Following are URLs where you can obtain information on other Texas Instruments products and application solutions:

### Products

Amplifiers	<a href="http://amplifier.ti.com">amplifier.ti.com</a>
Data Converters	<a href="http://dataconverter.ti.com">dataconverter.ti.com</a>
DSP	<a href="http://dsp.ti.com">dsp.ti.com</a>
Clocks and Timers	<a href="http://www.ti.com/clocks">www.ti.com/clocks</a>
Interface	<a href="http://interface.ti.com">interface.ti.com</a>
Logic	<a href="http://logic.ti.com">logic.ti.com</a>
Power Mgmt	<a href="http://power.ti.com">power.ti.com</a>
Microcontrollers	<a href="http://microcontroller.ti.com">microcontroller.ti.com</a>
RFID	<a href="http://www.ti-rfid.com">www.ti-rfid.com</a>
RF/IF and ZigBee® Solutions	<a href="http://www.ti.com/lprf">www.ti.com/lprf</a>

### Applications

Audio	<a href="http://www.ti.com/audio">www.ti.com/audio</a>
Automotive	<a href="http://www.ti.com/automotive">www.ti.com/automotive</a>
Broadband	<a href="http://www.ti.com/broadband">www.ti.com/broadband</a>
Digital Control	<a href="http://www.ti.com/digitalcontrol">www.ti.com/digitalcontrol</a>
Medical	<a href="http://www.ti.com/medical">www.ti.com/medical</a>
Military	<a href="http://www.ti.com/military">www.ti.com/military</a>
Optical Networking	<a href="http://www.ti.com/opticalnetwork">www.ti.com/opticalnetwork</a>
Security	<a href="http://www.ti.com/security">www.ti.com/security</a>
Telephony	<a href="http://www.ti.com/telephony">www.ti.com/telephony</a>
Video & Imaging	<a href="http://www.ti.com/video">www.ti.com/video</a>
Wireless	<a href="http://www.ti.com/wireless">www.ti.com/wireless</a>

Mailing Address: Texas Instruments, Post Office Box 655303, Dallas, Texas 75265  
Copyright © 2008, Texas Instruments Incorporated