

#5-20 SELF-TAPPING SCREWS, ZINC PL. STEEL (Q. TY 2)

CORPO CORAZZA (CABLE CLAMP BODY)

(CLAMPING INSERT)

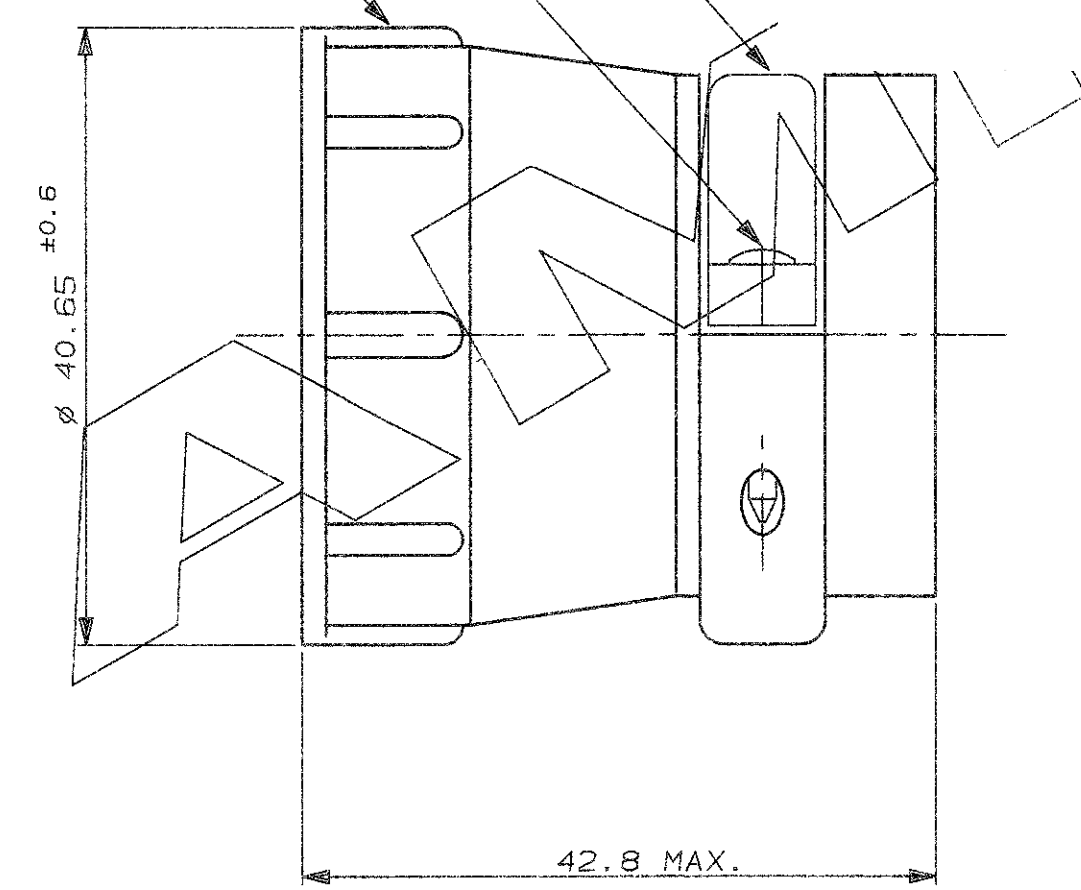
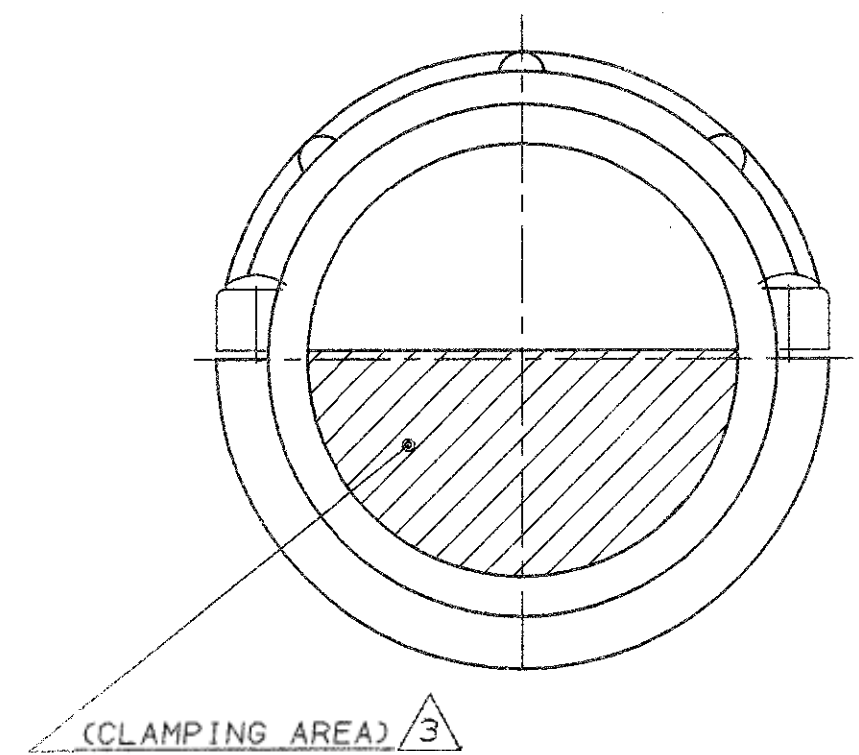

1. MATERIAL: BLACK THERMOPLASTIC RATED F1 FOR OUTDOOR SUITABILITY PER UL 946C.
2. PARTS PACKAGED UNASSEMBLED IN A PLASTIC BAG
3. CABLE CLAMPING AREA ADJUSTABLE FROM 168.38 TO 368.38 mm² (.261 TO .571 in²) BY SELECTING AND REVERSING CLAMPING INSERTS
4. Ø28.58 (1.125) MAXIMUM CABLE OUTSIDE DIAMETER

AS SHOWN 182930-1

| | | | | | |
|------------------------------|--|--|--|--|--|
| | | CUSTOMER DRAWING FOR REFERENCE ONLY | | DISEGNO PER CLIENTE SOLO PER RIFERIMENTO | |
| | | THIS DRAWING IS UNPUBLISHED | | RELEASE FOR PUBLICATION 19 | |
| | | © COPYRIGHT 19 BY AMP INCORPORATED, HARRISBURG, PA. ALL INTERNATIONAL RIGHT RESERVED. AMP PRODUCTS MAY BE COVERED BY U.S. AND FOREIGN PATENT AND/OR PATENT PENDING | | | |
| | | TOLLERANZE: SE NON DIVERSAMENTE SPECIFICATO (TOLERANCES: UNLESS OTHERWISE SPECIFIED) | | DIAM. ISOLANTE (INS. DIA. RANGE) RANGO FILO (WIRE RANGE) SCALA (SCALE) | |
| | | ± 0.3 | | - | |
| | | ± 2° | | - | |
| D ECN-22-137327 | | RK MZ 02FEB 2022 | | ANGOLI (ANGLES) | |
| C2 REVISED PER ECO-09-026346 | | KK AEG 28NOV 09 | | DTS. (DR.) | |
| C1 | | AV. 2807/05 | | C. CORDOLA 22 JUNE 91 | |
| B ADDED DASH | | 23-5-94 | | DESCRIZIONE (DESCRIPTION) | |
| A RELEASED | | C. C. 10-91 | | C.P.C. CABLE CLAMP KIT, SIZE 23 (LARGE) | |
| REV. (REVISION RECORD) | | DIS. DATA (DR) | | LOC. SIZE NUMERO (CWS. NO.) | |
| | | | | I A3 C - 182930 | |
| | | | | REV. (REV.) | |
| | | | | FOGLIO (SHEET) 1 D1 (OF) 1 | |

DISTRIBUZIONE (PRINT DIST.)