

Features
<ul style="list-style-type: none"> ±10ppm (Tolerance) Available Plastic SMD Type Tape and Reel

Applications
<ul style="list-style-type: none"> Real Time Clock Measurement instruments Wireless Applications

Part Numbering Guide

SWS 14 4 12 D 48 A - 32.768K

SUNTSU WATCH SMT CRYSTAL

10.4mm x 4.06mm

4 PAD

LOAD CAPACITANCE
12 : 12.5pF
9 : 9.0pF
6 : 6.0pF

FREQUENCY TOLERANCE
D : ±20ppm
F : ±10ppm

OPERATING TEMPERATURE RANGE
48 : -40°C - +85°C

FREQUENCY kHz

Package Type*
A : Type A
B : Type B

Cage Code: 4GUT4
* Electrode Arrangement, see outline drawing
To customize your parameters contact a Suntsu representative.

Electrical Parameters	Units	Minimum	Typical	Maximum	Remarks
Frequency Range	kHz		32.768		
Frequency Tolerance at +25°C	ppm	-20		+20	See part numbering guide for options.
Frequency Stability vs. Aging	ppm	-3		+3	First year @ +25°C.
Frequency Coefficient (β)	ppm/T ²	-0.040	-0.034	-0.028	
Operating Temperature	°C	-40		+85	
Turnover Temperature	°C	+20	+25	+30	
Storage Temperature	°C	-55		+125	
Load Capacitance	pF		12.5		See part numbering guide for options.
Shunt Capacitance	pF		1.9		
Drive Level	μW			1	
Insulation Resistance	MΩ	500			@ 100VDC ± 15V.
Equivalent Series Resistance	kΩ			50	

Outline Drawing & Recommended Land Pattern

All dimensions are in millimeters (mm) unless otherwise noted. Drawings are not to scale.

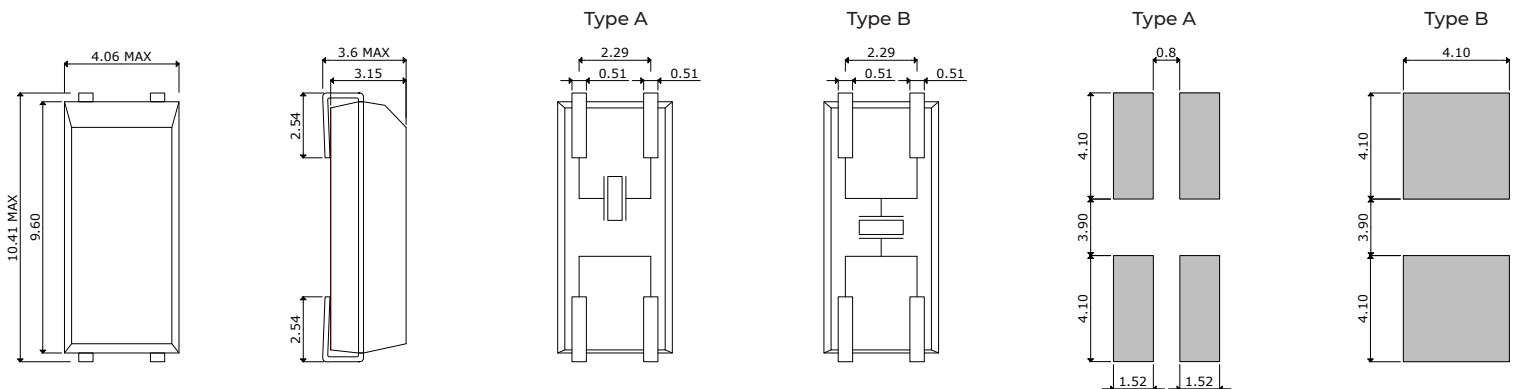
Electrode Arrangement

Environmental Specifications		Mechanical Specifications	
Temperature Cycling	MIL-STD-883, Method 1010, Condition B	Mechanical Shock	MIL-STD-202, Method 213, Condition B
Fine Leak Test	MIL-STD-883, Method 1014, Condition A	Vibration	MIL-STD-883, Method 2007, Condition A
Gross Leak Test	MIL-STD-883, Method 1014, Condition C	Resistance to Soldering Heat	MIL-STD-202, Method 210, Condition B
Moisture Resistance	MIL-STD-883, Method 1004	Resistance to Solvents	MIL-STD-202, Method 215
Moisture Sensitivity	J-STD-020, MSL 1	Solderability	MIL-STD-883, Method 2003

Reflow Profile & Part Marking

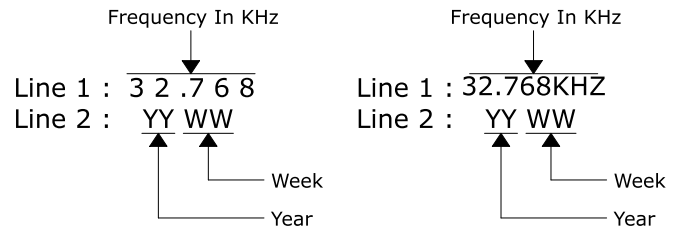
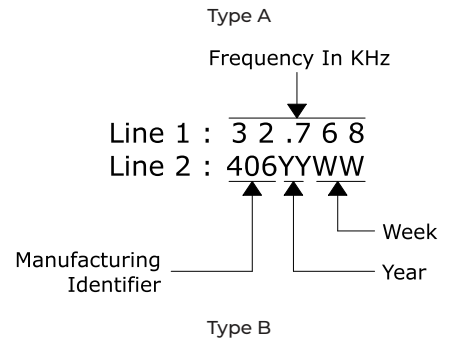
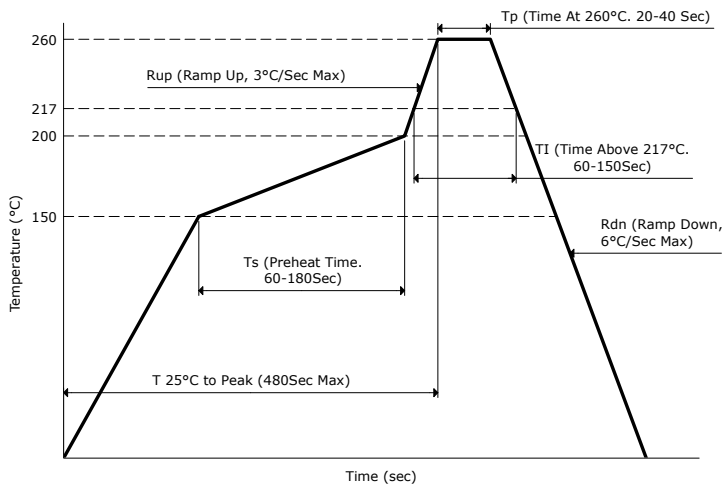

Tape And Reel Dimensions

All dimensions are in millimeters (mm) unless otherwise noted. Drawings are not to scale.

2,000pcs / Reel

