

REVISIONS					
P	LTR	DESCRIPTION	DATE	DWN	APVD
A		INITIAL RELEASE	26OCT2020	TL	HL

NOTE:

- MATERIAL:
HOUSING: THERMOPLASTIC, UL94 V-0, COLOR: BLACK COLOR.
CONTACTS: PHOSPHOR BRONZE.
- FINISH:
CONTACTS: [SEE TABLE]u" MIN. GOLD PLATING ON THE CONTACT AREA,
3.0um [120u"] MIN. MATTE-TIN ON SOLDER TAIL.
1.27um [50u"] MIN. NICKEL UNDERPLATED OVERALL.

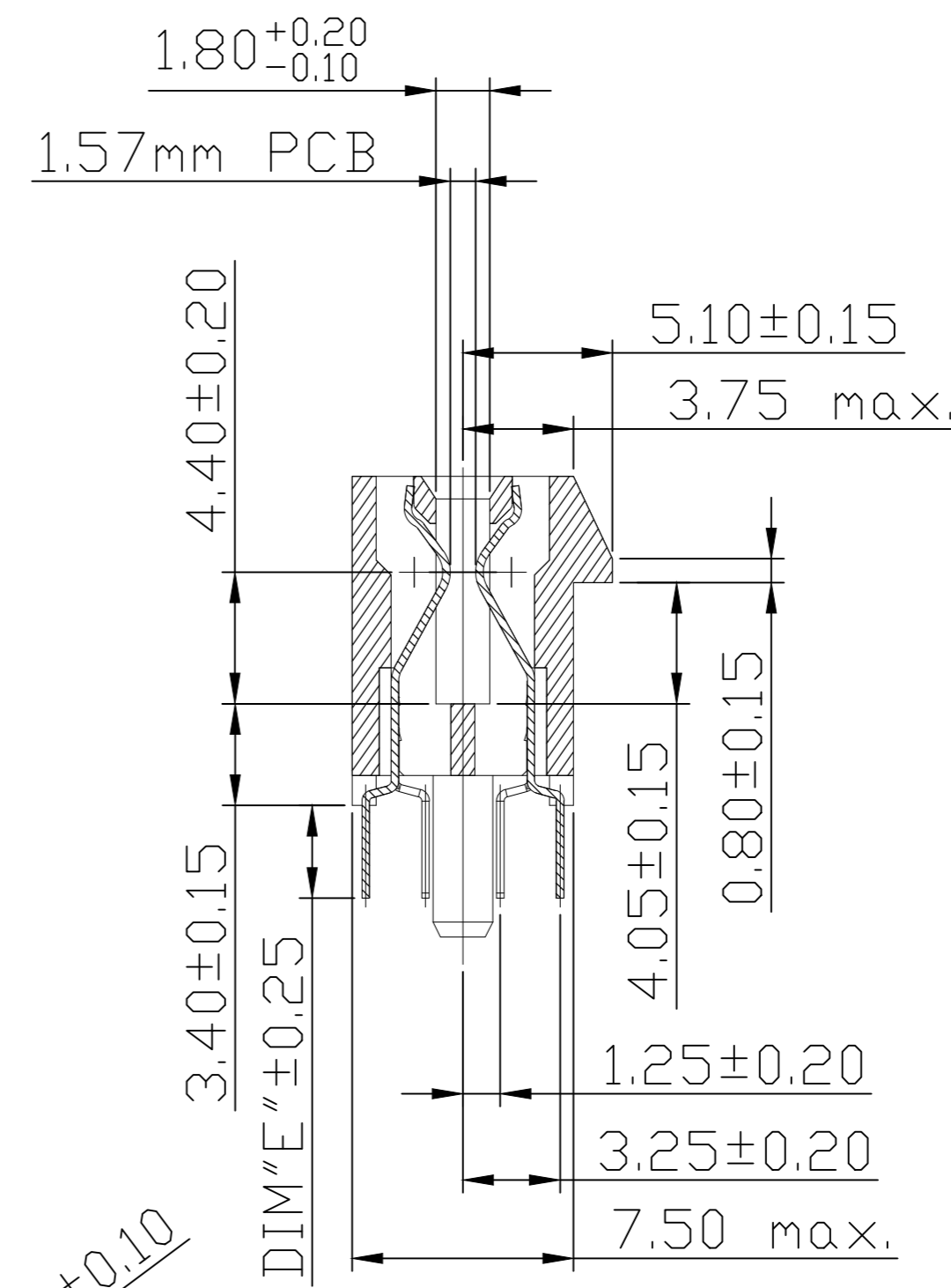
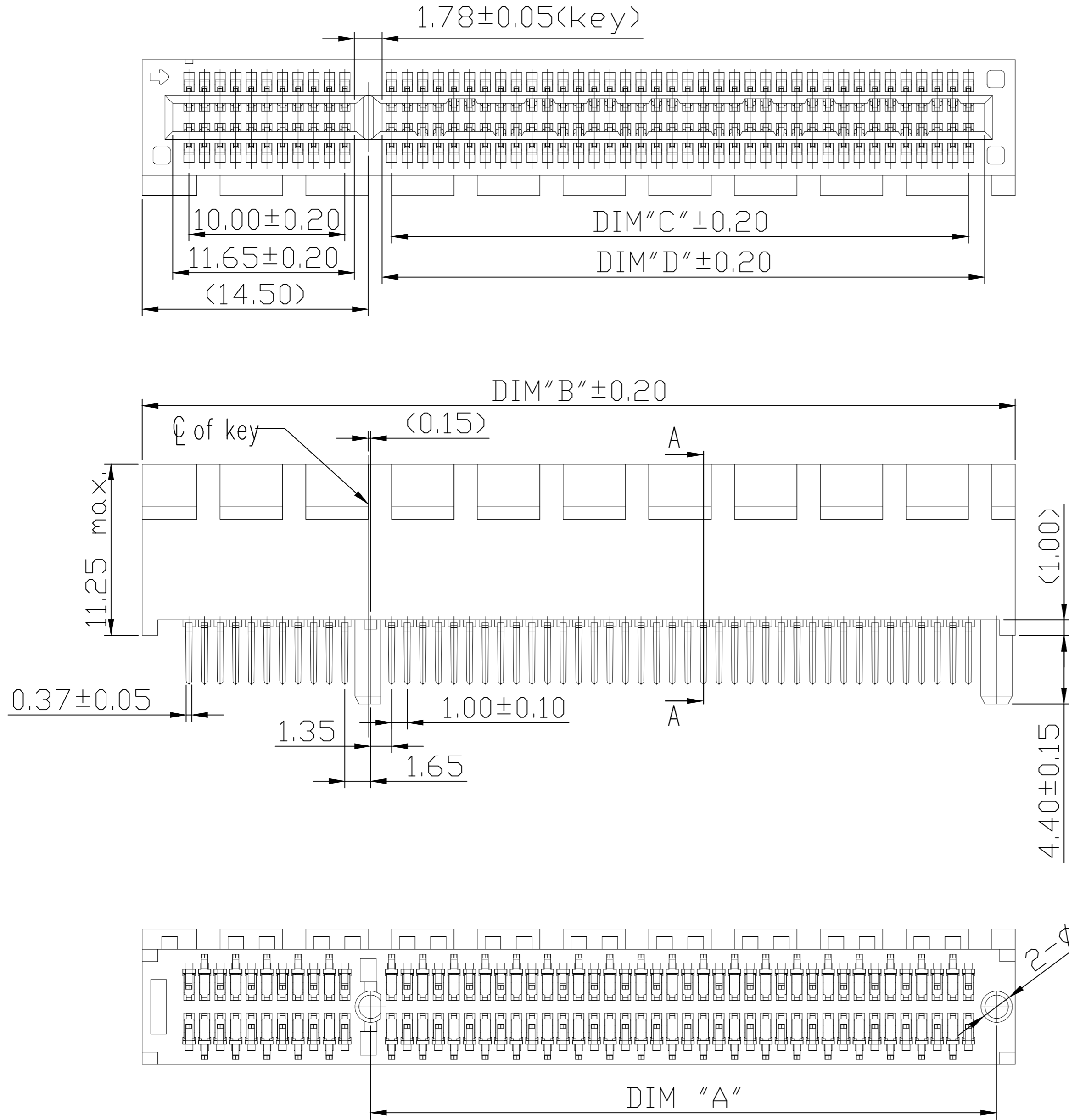

SECTION A-A

CONNECTOR LINK WIDTH	# PDS REF	DIM 'A'	DIM 'B'	DIM 'C'	DIM 'D'	DIM 'E'	PCB THK REF.
X1	36P	9.15	25.00	6.00	7.65	2.30	1.58
X4	64P	23.15	39.00	20.00	21.65	3.10	2.36
X8	98P	40.15	56.00	37.00	38.65		
X16	164P	73.15	89.00	70.00	71.65		

THIS DRAWING IS A CONTROLLED DOCUMENT.

DWN TONY LI 04SEP2019	TE Connectivity Ltd.			
CHK ALEX SHOAL 04SEP2019				
APVD HOPE LU 04SEP2019				
PRODUCT SPEC				
APPLICATION SPEC	NAME			
WEIGHT 0	SIZE A2	CAGE CODE 00779	DRAWING NO. C=2362375	RESTRICTED TO
CUSTOMER DRAWING	SCALE 4:1	SHEET 1 of 4	REV A	

PCI EXPRESS CARD EDGE DIP TYPE GEN4 CONNECTOR

REVISIONS

P	LTR	DESCRIPTION	DATE	DWN	APVD
-	-	SEE SHEET 1	-	-	-

30u"	3.10	164	5-2362375-4
	3.10	98	5-2362375-3
	3.10	64	5-2362375-2
	3.10	36	5-2362375-1
15u"	3.10	164	4-2362375-4
	3.10	98	4-2362375-3
	3.10	64	4-2362375-2
	3.10	36	4-2362375-1
G/F	3.10	164	3-2362375-4
	3.10	98	3-2362375-3
	3.10	64	3-2362375-2
	3.10	36	3-2362375-1
30u"	2.30	164	2-2362375-4
	2.30	98	2-2362375-3
	2.30	64	2-2362375-2
	2.30	36	2-2362375-1
15u"	2.30	164	1-2362375-4
	2.30	98	1-2362375-3
	2.30	64	1-2362375-2
	2.30	36	1-2362375-1
G/F	2.30	164	2362375-4
	2.30	98	2362375-3
	2.30	64	2362375-2
	2.30	36	2362375-1
GOLD PLATING	E	POS.	PART NUMBER

DATE CODE & P/N

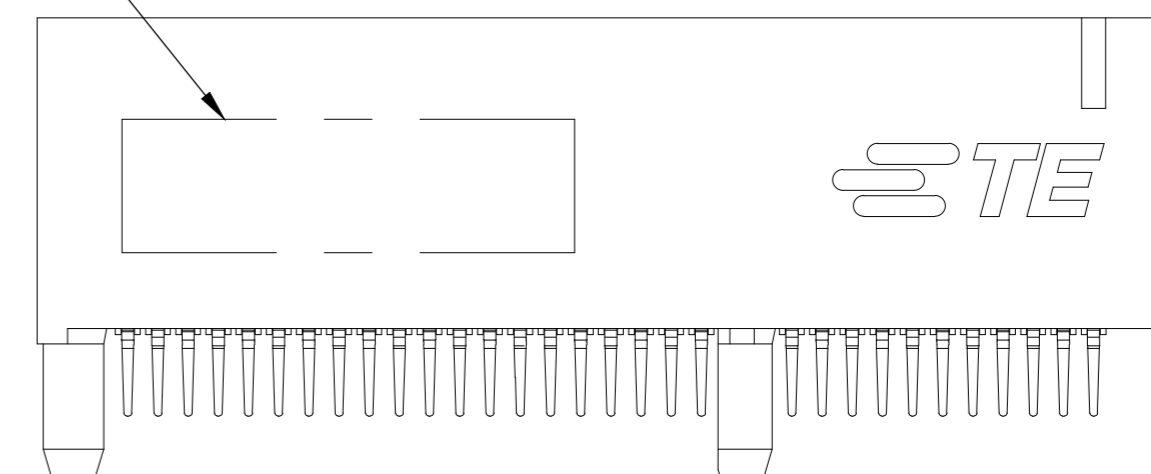

2362375

THIS DRAWING IS A CONTROLLED DOCUMENT.		DWN TONY LI 04SEP2019	TE Connectivity Ltd.	
DIMENSIONS: mm		CHK SANDERS YAN 04SEP2019		
TOLERANCES UNLESS OTHERWISE SPECIFIED:		APVD HOPE LU 04SEP2019	NAME PCI EXPRESS CARD EDGE DIP TYPE GEN4 CONNECTOR	
0 PLC ± - 1 PLC ± - 2 PLC ± - 3 PLC ± - 4 PLC ± - ANGLES ± -		PRODUCT SPEC -	RESTRICTED TO -	
MATERIAL -		FINISH -	WEIGHT -	SIZE A2
		CAGE CODE 00779		DRAWING NO C-2362375
		CUSTOMER DRAWING		SCALE 4:1
		SHEET 2 of 4		REV A

REVISIONS					
P	LTR	DESCRIPTION	DATE	DWN	APVD
-	-	SEE SHEET 1	-	-	-

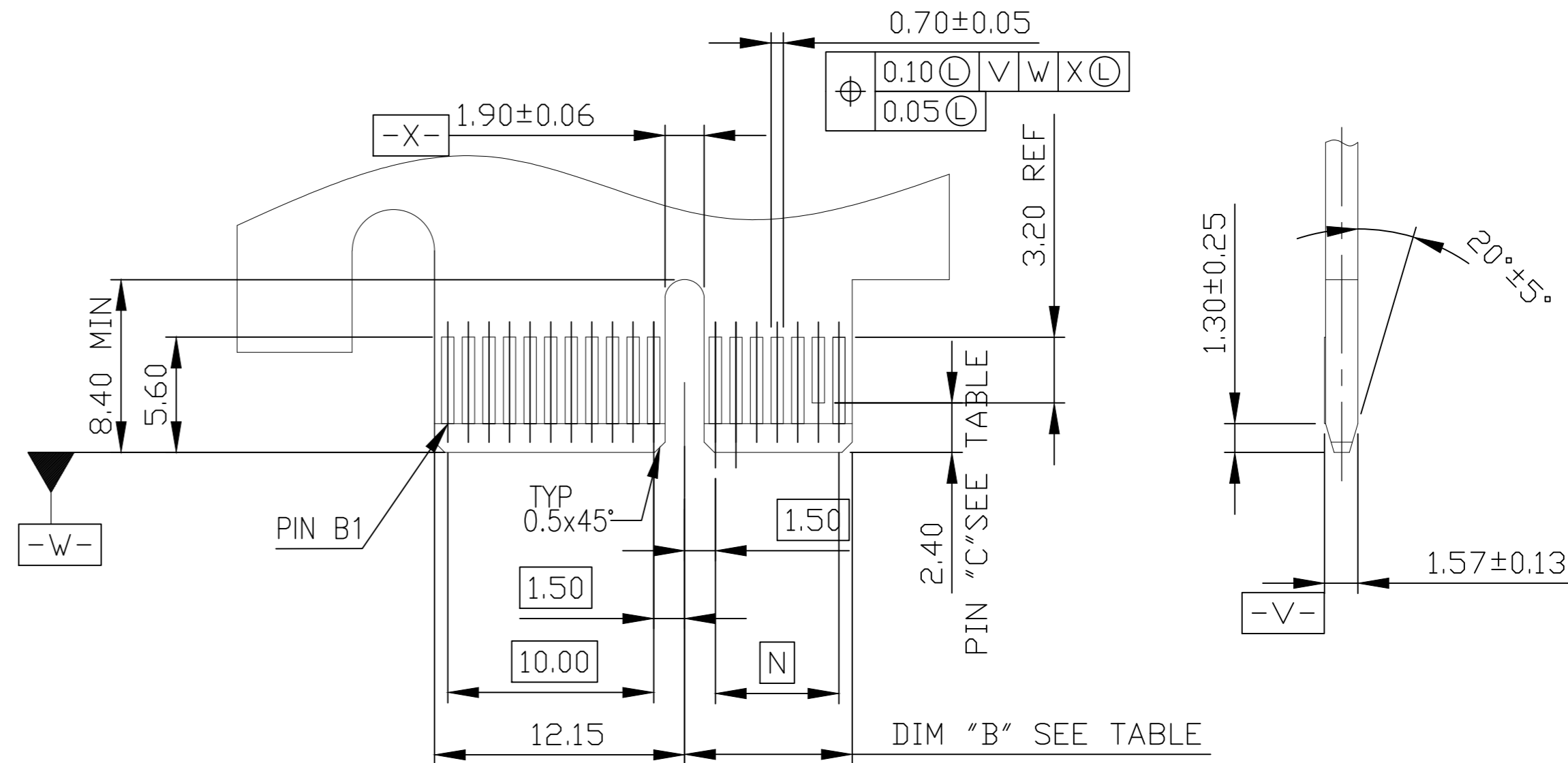
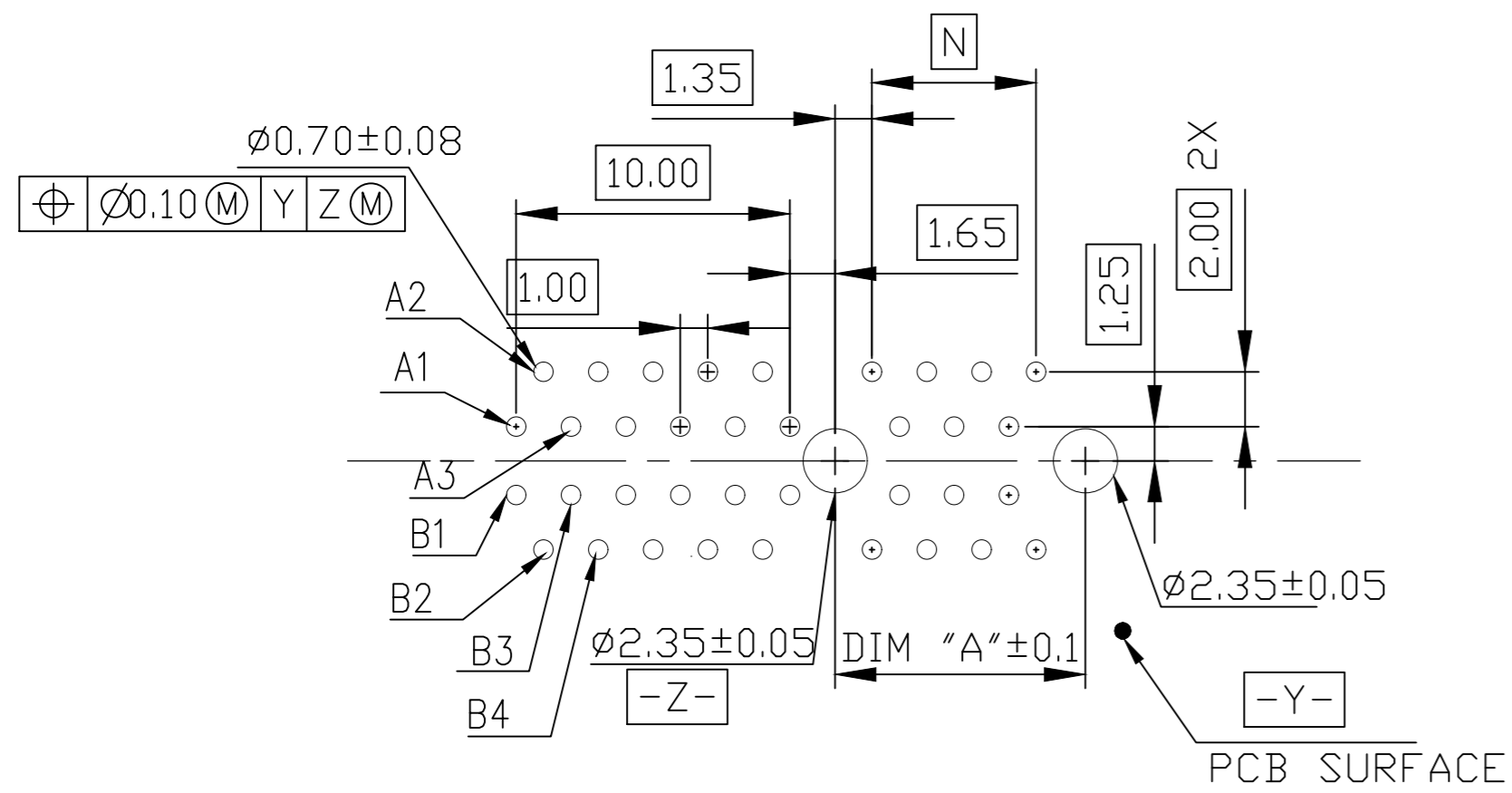

CONNECTOR LINK WIDTH	# POS REF	N	DIM "A"
X1	36P	6.00	9.15
X4	64P	20.00	23.15
X8	98P	37.00	40.15
X16	164P	70.00	73.15

CONNECTOR LINK WIDTH	# POS REF	N	DIM "B"	"C"
X1	36P	6.00	8.15	B17
X4	64P	20.00	22.15	B31
X8	98P	37.00	39.15	B48
X16	164P	70.00	72.15	B81

NOTES:

- 1 NO TIE BAR PERMITTED FROM CARD EDGE TO LEADING EDGE OF PAD FOR PINS A1 AND "C".
- 2 CHAMFER EDGES MUST BE FREE OF CUTTING BURRS.
- 3 TOLERANCE: .xx ± 0.13 .

THIS DRAWING IS A CONTROLLED DOCUMENT.

DWN TONY LI 04SEP2019
 CHK SANDERS YAN 04SEP2019
 APVD HOPE LU 04SEP2019

NAME: PCI EXPRESS CARD EDGE DIP TYPE GEN4 CONNECTOR

SIZE: A2 CAGE CODE: 00779 DRAWING NO: C=2362375 RESTRICTED TO: -

SCALE: 4:1 SHEET: 3 OF 4 REV: A

MATERIAL: - FINISH: - WEIGHT: - CUSTOMER DRAWING

DIMENSIONS:	TOLERANCES UNLESS OTHERWISE SPECIFIED:
mm	
	0 PLC ± -
	1 PLC ± -
	2 PLC ± -
	3 PLC ± -
	4 PLC ± -
	ANGLES ± -
	FINISH ± -

REVISIONS					
P	LTR	DESCRIPTION	DATE	DWN	APVD
-	-	SEE SHEET 1	-	-	-

PRODUCT

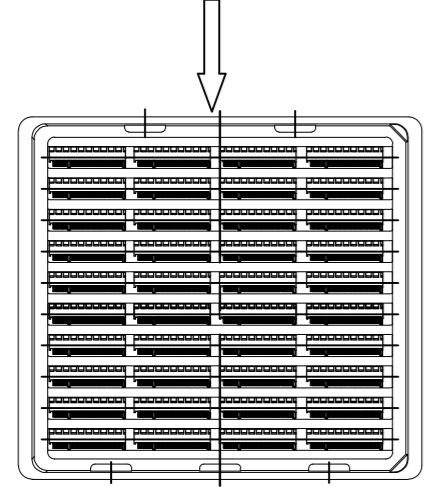

TRAY

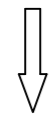

FIBER PAPER

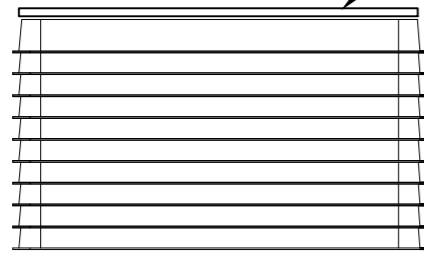

TRAY

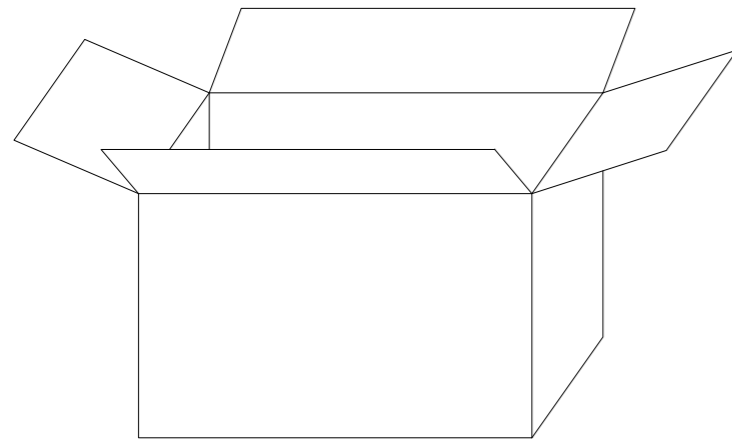

INNER BOX

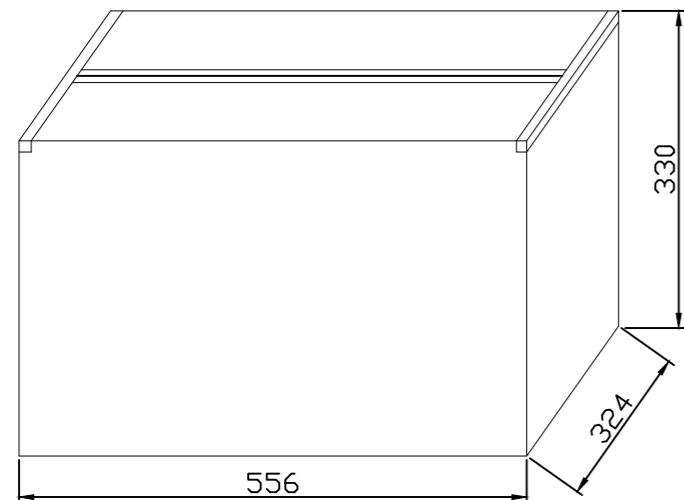
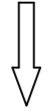

OUTER BOX

DRIER 4PCS(1g/PC)

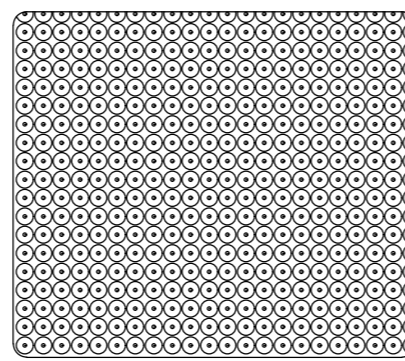
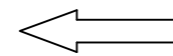
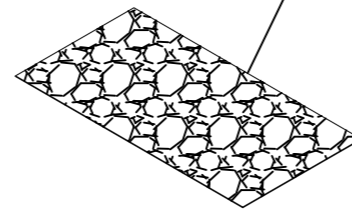

FOAM

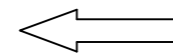

CODE	DESCRIPTION	PCS/TRAY	TRAY/INNER BOX	INNER BOX/OUTER BOX	PCS/OUTER BOX
4	X1	100	10	4	4000
3	X4	60	10	4	2400
2	X8	40	10	4	1600
1	X16	20	10	4	800
		QUANTITY			
		BOX			

THIS DRAWING IS A CONTROLLED DOCUMENT.		DWN TONY LI 04SEP2019	TE Connectivity Ltd.	
DIMENSIONS: mm		CHK SANDERS YAN 04SEP2019		
TOLERANCES UNLESS OTHERWISE SPECIFIED:		APVD HOPE LU 04SEP2019	NAME	
0 PLC ± -		PRODUCT SPEC	PCI EXPRESS CARD EDGE DIP TYPE GEN4 CONNECTOR	
1 PLC ± -		APPLICATION SPEC	-	
2 PLC ± -		WEIGHT 0	SIZE A2	RESTRICTED TO -
3 PLC ± -		FINISH -	CAGE CODE 00779	DRAWING NO C=2362375
4 PLC ± -		MATERIAL -	SCALE 4:1	SHEET 4 OF 4
ANGLES ± -		CUSTOMER DRAWING	REV A	