

Section I of this instruction sheet provides application procedures for AMP hand crimping tools.

Section II provides maintenance and inspection procedures for AMP hand crimping tools.

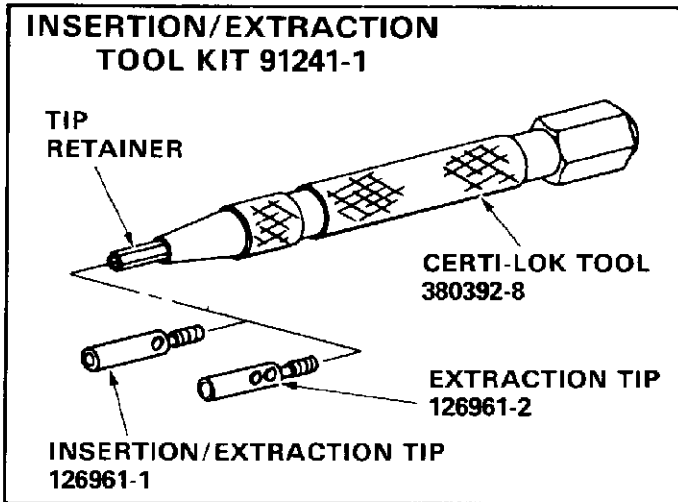

Fig. I-1

SECTION I APPLICATION

I-1. INTRODUCTION

AMP Insertion/Extraction Tool Kit 91241-1 includes the CERTI-LOK ★ Tool 380392-8, Insertion/Extraction Tip 126961-1 and Extraction Tip 126961-2. The kit will install and remove the AMP-LATCH ★ ACTION PIN ★ contacts listed in Figure I-2. The contacts listed in the chart are used with the AMP-LATCH Universal Header and are either inserted into or extracted from printed circuit (pc) boards.

I-2. DESCRIPTION

The CERTI-LOK tool 380392-8 is an impact tool featuring a spring-loaded handle and an internally-threaded tip retainer. The handle provides in-line force on the push tip assembly and the internal spring disengages automatically when the pre-set force is reached.

WARNING Do NOT depress the tool handle unless the tool is in its proper functional position; otherwise, damage to the tool and/or personal injury could result.

The insertion/extraction tip 126961-1 and extraction tip 126961-2 both feature external screw threads which allow them to be attached to the internally-threaded tip retainer of the CERTI-LOK tool.

I-3. EXTRACTION PROCEDURE

The extraction of the ACTION PIN contact depends on the type of pin to be extracted from the header

and pc board. Refer to the chart in Figure I-2 to determine the proper application.

A. Pin With Wrap-Type Post

To extract a wrap-type pin, proceed as follows:

1. Thread tip 126961-1, which has a deep hole in its center, into the tip retainer of the CERTI-LOK tool until it is finger-tight.
2. Place the tip over the wrap-type post of the ACTION PIN contact, holding the tool perpendicular to the pc board. Allow room for the pin to eject from the other side of the board, making certain that your hand is clear of the ejection area to avoid possible injury.
3. Press the CERTI-LOK tool toward the board until a snapping action (spring release) occurs. It may take two or more applications of pressure on the tool to free the pin from the board.
4. Remove the tool from the pin and withdraw the ACTION PIN contact from the header on the other side of the board with your fingers.
5. Discard the extracted pin.

NOTE It is recommended that pins extracted from the pc board be discarded and replaced with new pins.

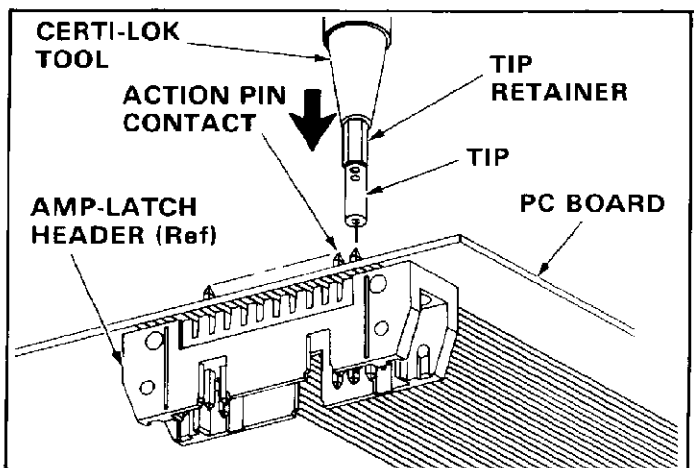

CONTACT PART NO.	TIP PART NO.	
	EXTRACTION	INSERTION
746307-1	126961-1	126961-1 ↓
746307-2	126961-1	
746307-3	126961-2	
746307-4	126961-2	

Fig. I-2

Copyright 1983 by AMP Incorporated, Harrisburg, PA. All International Rights Reserved. AMP Incorporated products covered by U.S. and Foreign patents and/or patents pending.

* Trademark of AMP Incorporated

B. Pin With Short Post

To extract a pin with a short post, proceed as follows:

1. Thread tip 126961-2, which has a shallow indentation in its center, into the tip retainer of the CERTI-LOK tool until it is finger-tight.
2. Place the indentation over the short post of the ACTION PIN contact, holding the tool perpendicular to the pc board. Allow room for the pin to eject from the header on the other side of the board, making certain that your hand is clear of the ejection area to avoid possible injury.
3. Press the tool toward the board until a snapping action (spring release) occurs.
4. Grasp the partially-ejected pin with a pair of needle-nose pliers and withdraw it from the header, taking care not to damage the adjacent contacts. Use of pliers is necessary because the extraction tip will not force the pin completely out of the board. If the pin does not pull free, repeat steps 2 and 3.
5. Discard the extracted pin.

I-4. INSERTION PROCEDURE

The insertion procedure for all pins described in the chart in Figure I-2 is accomplished with tip 126961-1. Proceed as follows:

1. Place a *new* ACTION PIN contact into the AMP-LATCH header and through the corresponding hole in the pc board. The push shoulders of the pin should point to the sides, not toward the ends, of the header.
2. Place the CERTI-LOK tool, with tip 126961-1 (deep hole) attached, over the pin in the header. Keeping the tool perpendicular to

AMP INSERTION/EXTRACTION KIT 91241-1

the pc board, press the tool into the header until a snapping action (spring release) occurs. Two or three applications of pressure on the tool may be required to fully insert the pin.

3. Visually determine that the insertion is complete after removing the tool. The pin is properly inserted when the push shoulders of the pin are flush with the bottom of the header.

SECTION II MAINTENANCE/INSPECTION

II-1. INSPECTION AND MAINTENANCE

Insertion/Extraction Tool Kit 91241-1 requires little maintenance other than to ensure that it is properly stored when it is not in use. Care should be exercised with regard to deep-hole tip 126961-1 to ensure that no foreign objects or substances enter the tip and block the opening. The CERTI-LOK tool release pressure is factory set at 16 to 18 pounds pressure and should not be adjusted by the customer.

Regular inspections should be performed by quality control personnel. A record of scheduled inspections should remain with the tool and/or be supplied to the supervisory personnel responsible for the tool.

II-2. REPAIR

Parts other than those specified in Figure II-1 must be replaced by AMP to ensure certification of the tool. When repair is necessary, return the tool with a written description of the problem to:

AMP Incorporated
 Customer Repair
 1523 North 4th Street
 Harrisburg, Pennsylvania 17102

or a wholly owned subsidiary of AMP Incorporated.

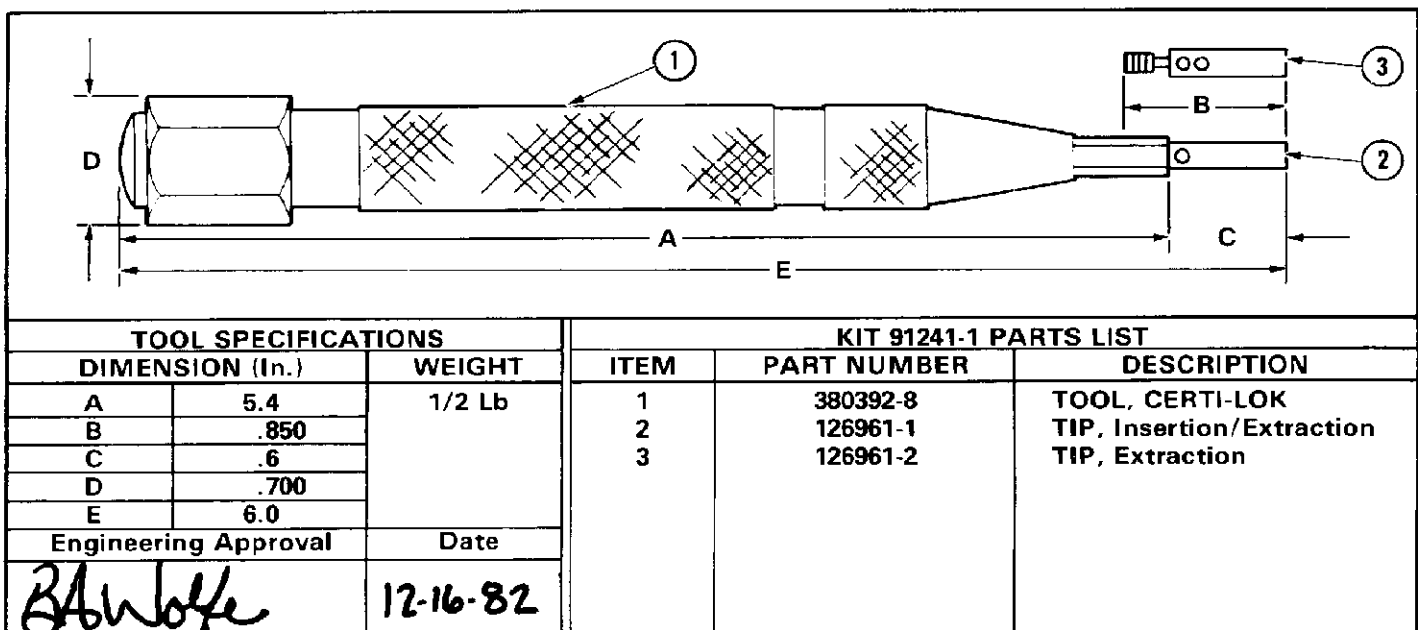

Fig. II-1