



Features

- ESD protect for super speed differential signaling (above 10Gb/s) channels
- ESD protect USB3.1/3.0 **TX+, TX-, RX+, and RX-** Pins operating up to **2.2V** and below
- ESD protect USB2.0 **D+ and D-** Pins operating up to **3.3V** and below
- ESD protect USB **VBus** operating up to **5.0V** and below
- Provide transient protection for each channel to **IEC 61000-4-2 (ESD) ±15kV (air), ±10kV (contact)**
IEC 61000-4-5 (Lightning) 4A (8/20μs)
- **Ultra low capacitance: 0.35pF typ.**
- Fast turn-on and low clamping voltage
- Array of surge rated diodes with internal equivalent TVS diode
- Solid-state silicon-avalanche and active circuit triggering technology
- **Green part**

Applications

- **USB3.1 and USB3.0**
- **Thunderbolt**
- **10G/5G/2.5G Ethernet**
- **High speed I/O ports in any electronic product**

Description

AZ1365-06F is a design which includes ESD rated diode arrays to protect high speed data interfaces. The AZ1365-06F has been specifically designed to protect sensitive components which are connected to data and transmission lines from over-voltage caused by Electrostatic Discharging (ESD).

AZ1365-06F is a unique design which includes surge rated, ultra low capacitance steering diodes and a unique design of clamping cell which is an equivalent TVS diode in a single package. During transient conditions, the steering diodes direct the transient to either the power supply line or to ground line. The internal unique design of clamping cell prevents over-voltage on the power line, protecting any downstream components.

AZ1365-06F may be used to meet the ESD immunity requirements of IEC 61000-4-2, Level 4 (±15kV air, ±8kV contact discharge).

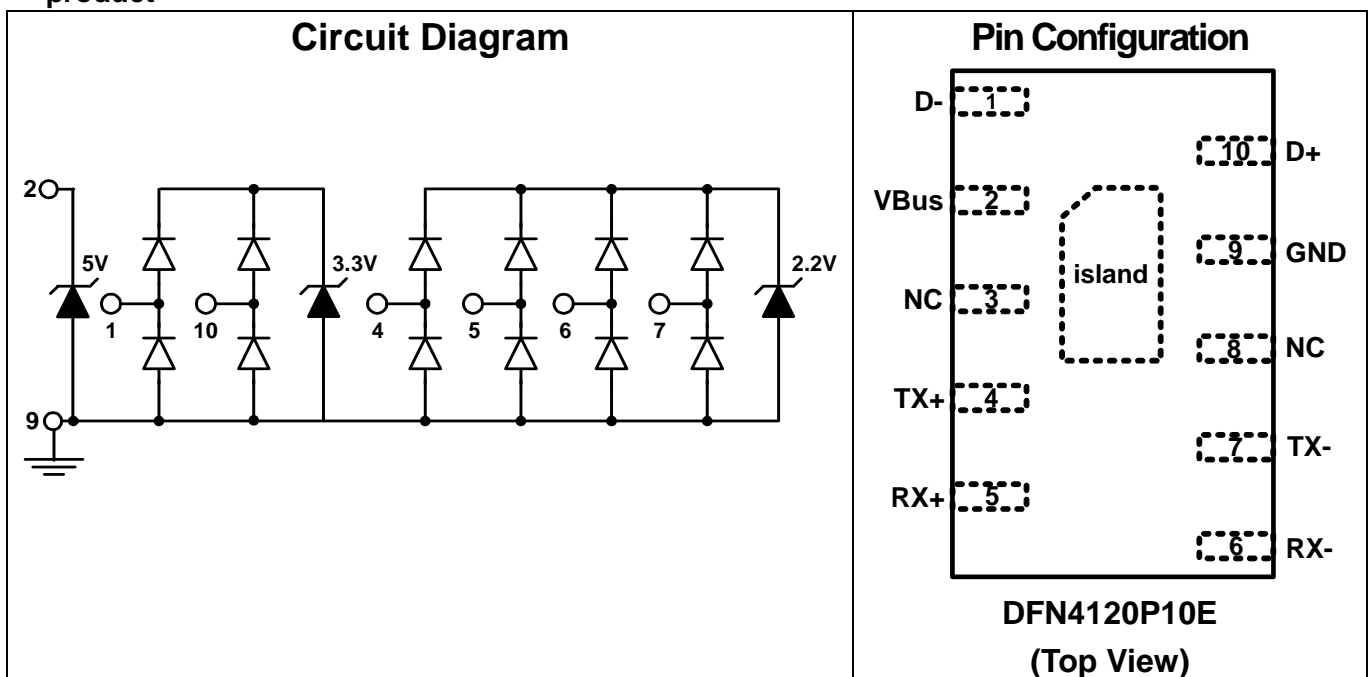



SPECIFICATIONS

ABSOLUTE MAXIMUM RATINGS			
PARAMETER	SYMBOL	RATING	UNITS
TX+, TX-, RX+, RX- (Pin 4, 5, 6, 7)			
Operating Voltage (I/O-GND)	V_{DC_IO1}	2.4	V
D+, D- (Pin 1, 10)			
Operating Voltage (I/O-GND)	V_{DC_IO2}	3.6	V
VBus (Pin 2)			
Operating Supply Voltage (VBus-GND)	V_{DC_VBus}	5.5	V
Peak Pulse Current (tp= 8/20μs)	I_{PP}	4	A
ESD per IEC 61000-4-2 (Air)	V_{ESD}	±15	kV
ESD per IEC 61000-4-2 (Contact)		±10	
Lead Soldering Temperature	T_{SOL}	260 (10 sec.)	°C
Operating Temperature	T_{OP}	-40 to +85	°C
Storage Temperature	T_{STO}	-55 to +150	°C

ELECTRICAL CHARACTERISTICS						
TX+, TX-, RX+, RX- (Pin 4, 5, 6, 7)						
PARAMETER	SYMBOL	CONDITIONS	MIN	TYP	MAX	UNITS
Reverse Stand-Off Voltage	V_{RWM}	Pin-4,-5,-6,-7 to pin-9, T=25 °C			2.2	V
Channel Leakage Current	I_{Leak}	$V_{Pin-4,-5,-6,-7} = 2.2V, V_{Pin-9} = 0V, T=25 °C$			1	μA
Reverse Breakdown Voltage	V_{BV}	$I_{BV} = 1mA, T=25 °C, pin-4,-5,-6,-7 to pin-9$	4.5			V
Snap-Back Voltage	V_{SB}	$I_{SB} = 50mA, T=25 °C, pin-4,-5,-6,-7 to pin-9$	2.4			V
Forward Voltage	V_F	$I_F = 15mA, T=25 °C, pin-9 to pin-4,-5,-6,-7$		0.9	1.2	V
ESD Clamping Voltage	V_{Clamp}	IEC 61000-4-2 +6kV, T=25 °C, Contact mode, any I/O pin to Ground		8.5		V
Channel Input Capacitance	C_{IN}	$V_{pin-9} = 0V, V_{IN} = 1.2V, f = 1MHz, T=25 °C, any I/O pin to Ground$		0.35	0.5	pF
Channel to Channel Input Capacitance	C_{CROSS}	$V_{pin9} = 0V, V_{IN} = 1.2V, f = 1MHz, T=25 °C, between I/O pins$		0.02	0.04	pF



ELECTRICAL CHARACTERISTICS						
D+, D- (Pin 1, 10)						
PARAMETER	SYMBOL	CONDITIONS	MIN	TYP	MAX	UNITS
Reverse Stand-Off Voltage	V_{RWM}	Pin-1,-10 to pin-9, T=25 °C			3.3	V
Channel Leakage Current	I_{Leak}	$V_{Pin-1,-10} = 3.3V$, $V_{Pin-9} = 0V$, T=25 °C			1	μA
Reverse Breakdown Voltage	V_{BV}	$I_{BV} = 1mA$, T=25 °C, pin-1,-10 to pin-9	4.5			V
Forward Voltage	V_F	$I_F = 15mA$, T=25 °C, pin-9 to pin-1,-10		0.9	1.2	V
ESD Clamping Voltage	V_{Clamp}	IEC 61000-4-2 +6kV, T=25 °C, Contact mode, any I/O pin to Ground		10.5		V
Channel Input Capacitance	C_{IN}	$V_{pin-9} = 0V$, $V_{IN} = 1.65V$, f = 1MHz, T=25 °C, any I/O pin to Ground		0.35	0.5	pF
Channel to Channel Input Capacitance	C_{CROSS}	$V_{pin9} = 0V$, $V_{IN} = 1.65V$, f = 1MHz, T=25 °C, between I/O pins		0.02	0.04	pF

ELECTRICAL CHARACTERISTICS						
VBus (Pin 2)						
PARAMETER	SYMBOL	CONDITIONS	MIN	TYP	MAX	UNITS
Reverse Stand-Off Voltage	V_{RWM}	Pin-2 to pin-9, T=25 °C			5	V
Leakage Current	I_{Leak}	$V_{Pin-2} = 5V$, $V_{Pin-9} = 0V$, T=25 °C			2.5	μA
Reverse Breakdown Voltage	V_{BV}	$I_{BV} = 1mA$, T=25 °C, pin-2 to pin-9	6		9.5	V
Forward Voltage	V_F	$I_F = 15mA$, T=25 °C, pin-9 to pin-2		0.8	1.2	V
ESD Clamping Voltage	V_{Clamp}	IEC 61000-4-2 +6kV, T=25 °C, Contact mode, pin-2 to pin-9		9		V

Typical Characteristics

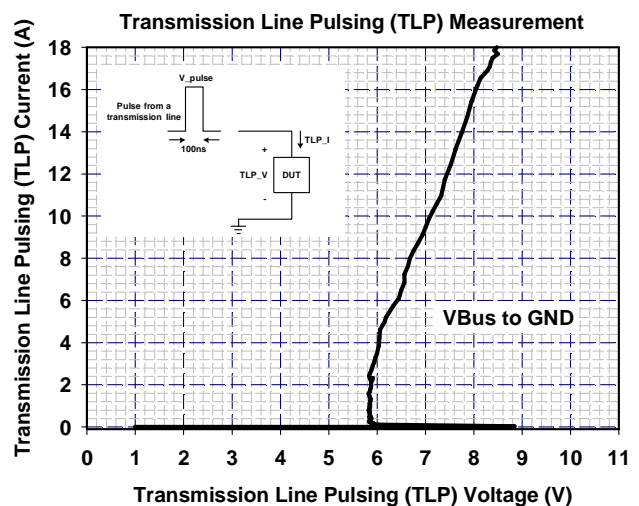
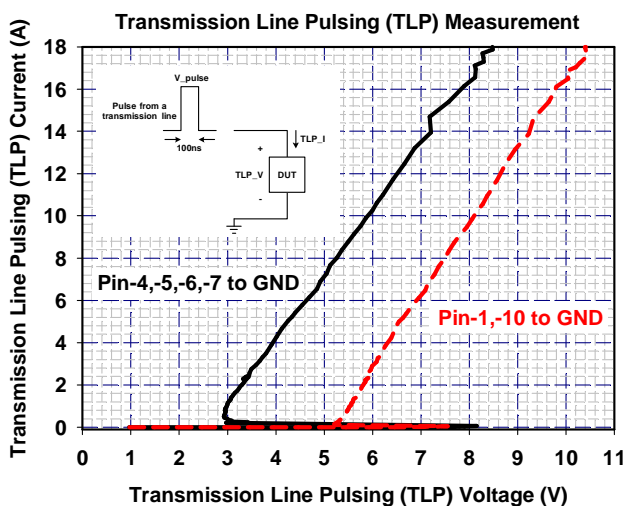
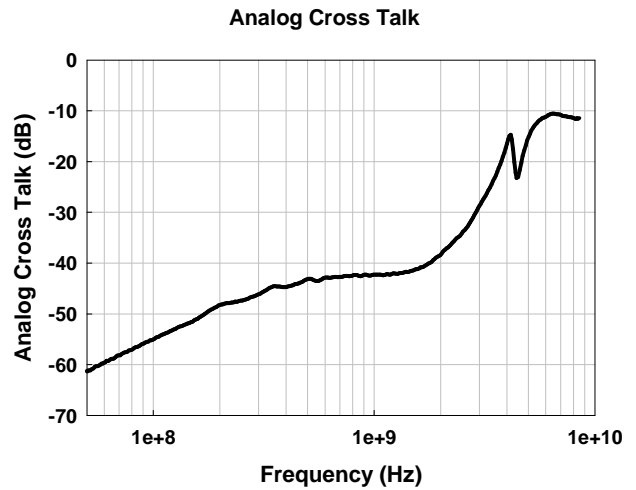
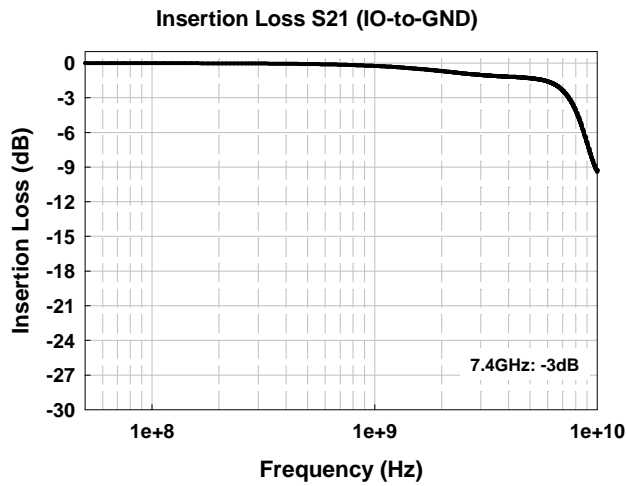
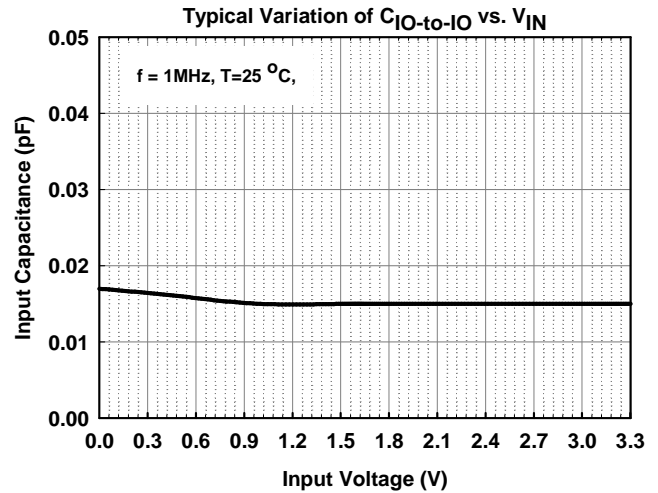
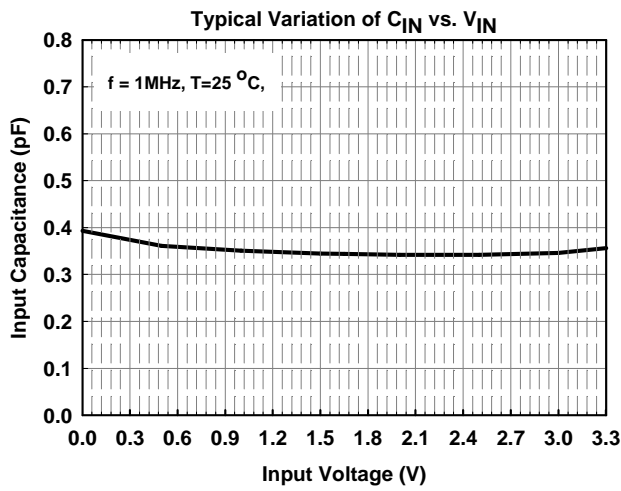

Applications Information

The AZ1365-06F is specifically designed for the ESD protection on USB3.1 or USB3.0 port. The usage of AZ1365-06F for an USB 3.1 or USB3.0 port is shown in Fig. 1. One AZ1365-06F can provide ESD protection for two SuperSpeed differential pairs (TX+/TX- and RX+/RX-), USB2.0 differential pair (D+/D-), and power line (VBus) of an USB3.0 or USB3.1 port simultaneously. In Fig. 1, the pins 1, 10, 4, 7, 5, and 6 are connected to the D-, D+, TX+, TX-, RX+, RX- data lines, respectively. These pins are designed with ultra-low capacitance (0.35pF typ.) to minimize the impact on signal integrity. The ground pin (pin9) of AZ1365-06F is a negative reference pin. This pin should be directly

connected to the GND rail of PCB (Printed Circuit Board). To get minimum parasitic inductance, the path length should keep as short as possible. In addition, the pin 2 of AZ1365-06F is connected to the USB voltage bus (VBus)

In some cases, systems are not allowed to be reset or restart after the ESD stress directly applying at the I/O-port connector. Under this situation, in order to enhance the sustainable ESD Level, a 0.1μF chip capacitor can be added between the VBus and GND rails. The place of this chip capacitor should be as close as possible to the AZ1365-06F.

In some cases, there isn't power rail presented on the PCB. Under this situation, the power pin (pin 2) of AZ1365-06F can be left as floating. Fig. 2 shows the detail connection.

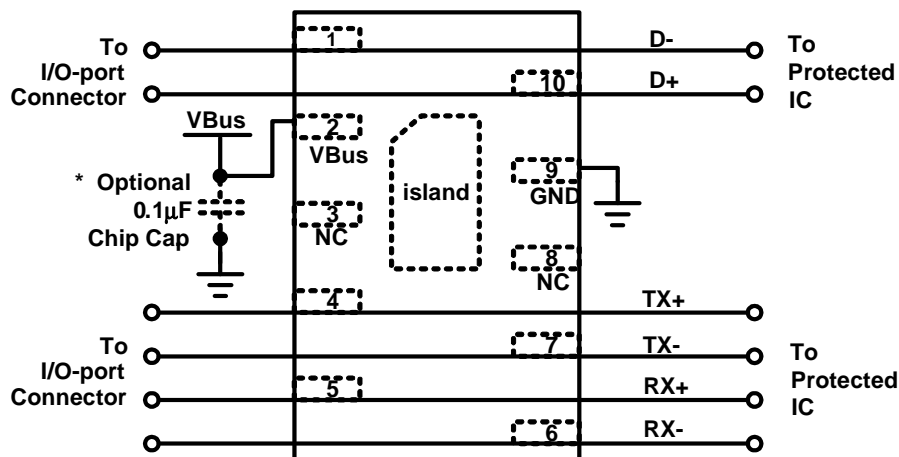

Fig. 1 The data lines and power rails connection of AZ1365-06F for an USB3.1 or USB3.0 port.

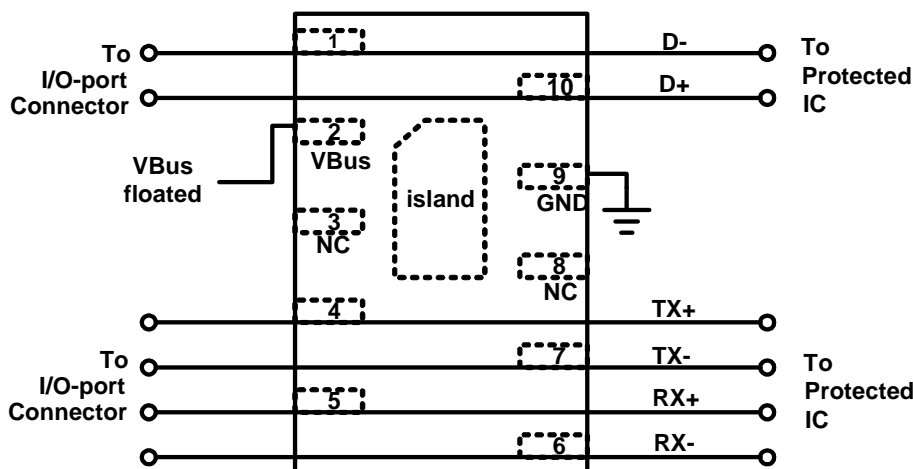

Fig. 2 The data lines connection of AZ1365-06F for an USB3.1 or USB3.0 port. VBus pin is left as floating when no power rail presented on the PCB.

Fig. 3 shows the PCB layout example for an USB3.1 or USB3.0 port. The use of DFN-10 package with the “feed through” layout can

provide a minimum impedance change on the high speed data lines.

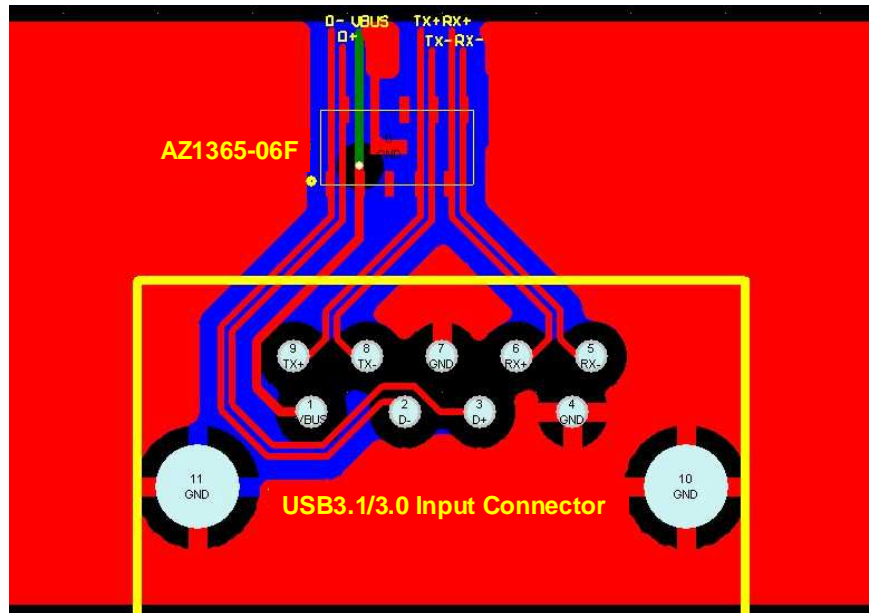

Fig. 3 The PCB layout of AZ1365-06F for an USB 3.1 or USB3.0 port.

Fig. 4 shows the PCB layout example for an Ethernet port with AZ1365-06F at secondary side for line-to-ground protection. The TX and RX pins are connected to pins 4, 5, 6, and 7

with the feed through layout. Pin 2 is connected to power line (VDD) and pin 9 is connected to GND. Pins 1 and 10 are left as NC pins.

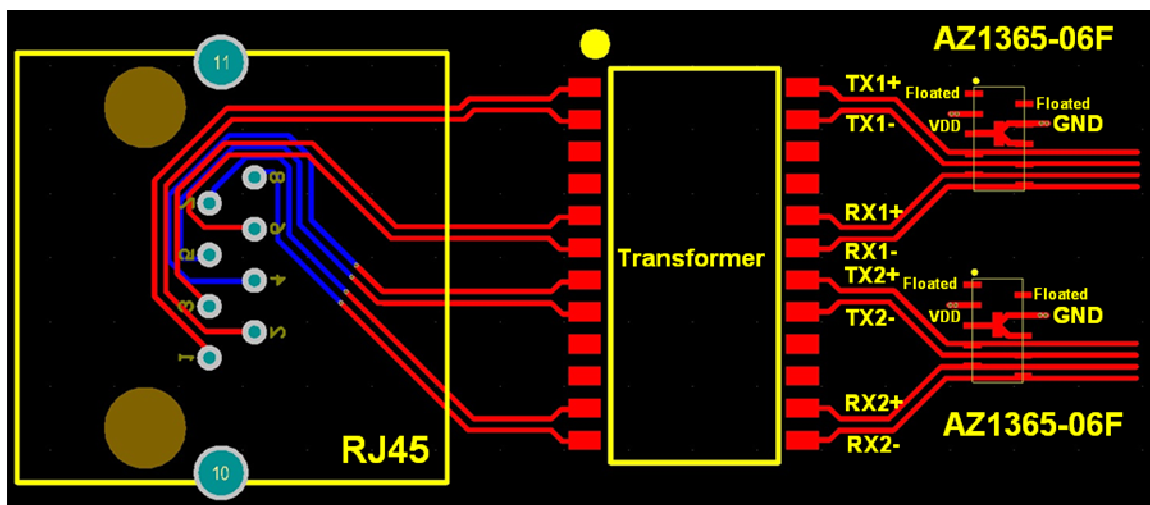
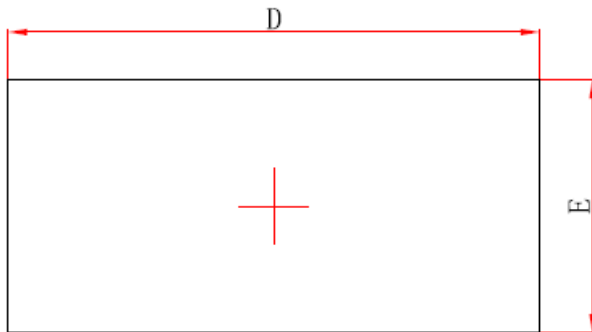

Fig. 4 The PCB layout of AZ1365-06F for an Ethernet port.

Mechanical Details

DFN4120P10E PACKAGE DIAGRAMS AND DIMENSIONS



Top View

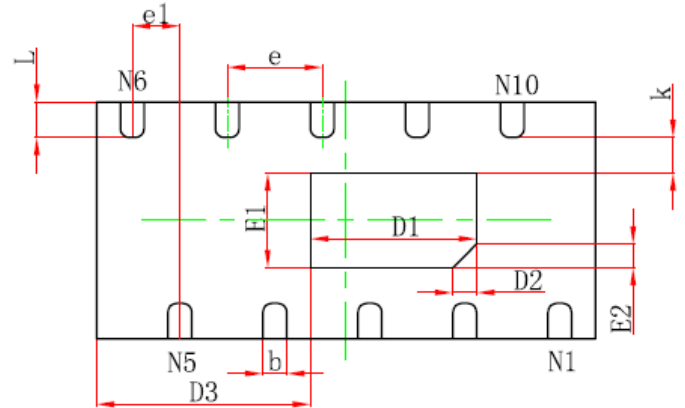

Bottom View

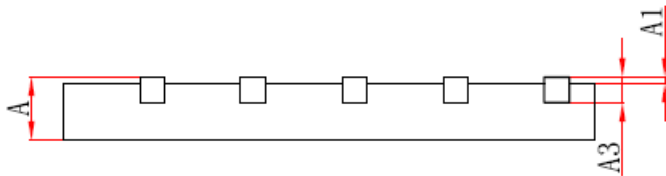

Side View

Symbol	Dimensions In Millimeters		Dimensions In Inches	
	Min.	Max.	Min.	Max.
A	0.450	0.550	0.018	0.022
A1	0.000	0.050	0.000	0.002
A3	0.152 REF		0.006REF	
D	4.050	4.150	0.159	0.163
E	1.950	2.050	0.077	0.081
D1	1.300	1.500	0.051	0.059
E1	0.700	0.900	0.028	0.035
D3	1.650	1.850	0.065	0.073
D2	0.200REF		0.008REF	
E2	0.200REF		0.008REF	
k	0.200MIN		0.008MIN	
b	0.150	0.250	0.006	0.010
e	0.800TYP		0.031TYP	
e1	0.350	0.450	0.014	0.018
L	0.250	0.350	0.010	0.014

LAND LAYOUT

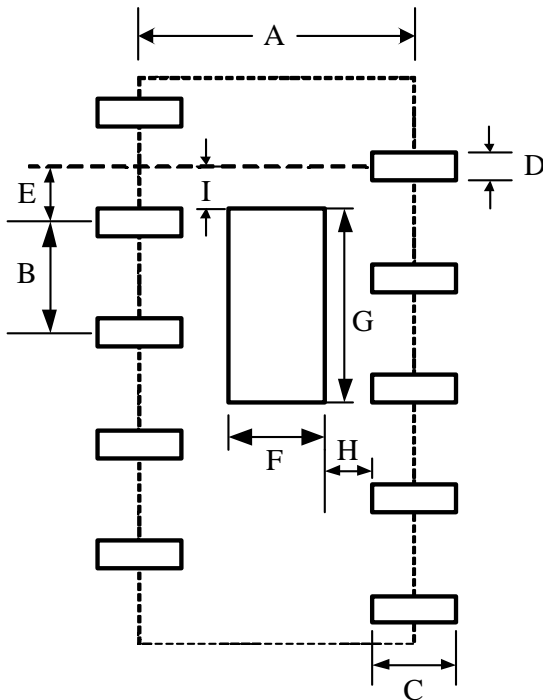

Symbol	Millimeters			Inches		
	Min.	Nom.	Max.	Min.	Nom.	Max.
A	1.924	2.000	2.076	0.076	0.079	0.082
B	0.800TYP.			0.031TYP.		
C	0.600TYP.			0.023TYP.		
D	0.150	0.200	0.250	0.006	0.008	0.010
E	0.400TYP.			0.015TYP.		
F	0.700	0.800	0.900	0.028	0.031	0.035
G	1.300	1.400	1.500	0.051	0.055	0.059
H	0.200MIN.			0.008MIN.		
I	0.300TYP.			0.012TYP.		

Notes:

This LAND LAYOUT is for reference purposes only. Please consult your manufacturing partners to ensure your company's PCB design guidelines are met.

MARKING CODE

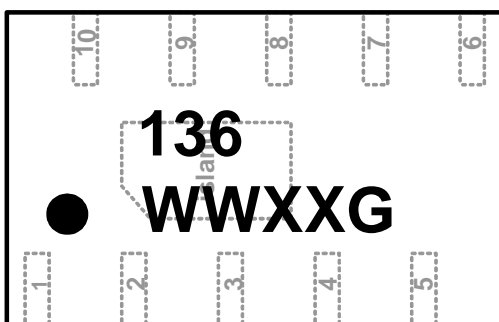

136 = Device Code
WW = Date Code
XX = Control Code
G = Green part

Part Number	Marking Code
AZ1365-06F.R7G (Green part)	136 .WWXXG

Note. Green means Pb-free, RoHS, and Halogen free compliant.



Ordering Information

PN#	Material	Type	Reel size	MOQ	MOQ/internal box	MOQ/carton
AZ1365-06F.R7G	Green	T/R	7 inch	3,000/reel	3 reels= 9,000/box	6 boxes =54,000/carton

Revision History

Revision	Modification Description
Revision 2014/04/30	Preliminary Release.
Revision 2014/05/14	Add the Lightning (8/20 μ s) spec.
Revision 2014/12/11	Formal Release.
Revision 2019/06/14	Add the application of 10G/5G/2.5G Ethernet.