

Interactive Catalog Replaces Catalog Pages

Honeywell Sensing and Control has replaced the PDF product catalog with the new **Interactive Catalog**. The **Interactive Catalog** is a power search tool that makes it easier to find product information. It includes more installation, application, and technical information than ever before.



**Click this icon to try the new
Interactive Catalog.**

Sensing and Control

Honeywell Inc.

11 West Spring Street

Freeport, Illinois 61032

Solid State Sensors

SR16/17 Hall Effect Vane Sensors

SR 16/17 Series

FEATURES

- Compact, robust packages
- Mechanically interchangeable with our standard optical style sensors
- Operated by a “Ferrous Vane” interrupter for pulse counting or position sensing
- Current sinking (Open Collector) output
- 3.8 to 30 VDC power supply
- Medium level magnetic switching to reduce stray field interference
- Internally sealed packages for moderate environment applications
- No mechanical contacts; eliminates product wear
- Noncontact position sensing

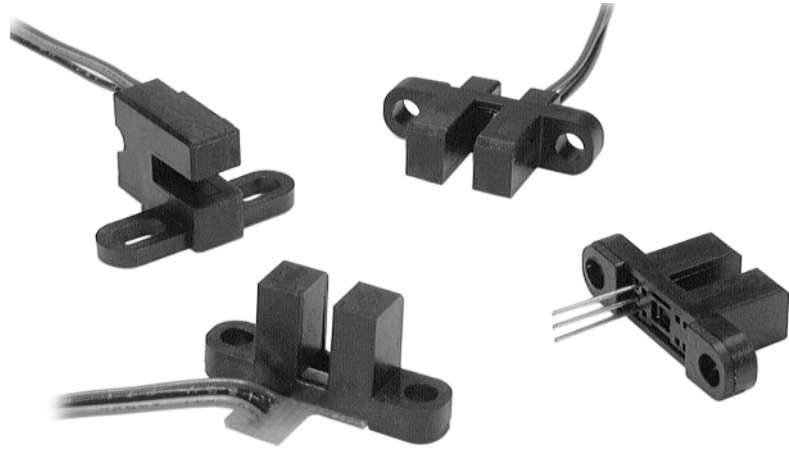

The SR16/17 Series Hall effect vane sensors, designed for position and speed sensing, offer side mount packages and three termination variations. The cost effective SR16/17 Series sensors are tailored for fitness and information technology applications. They are well suited for use in moderate electrical, chemical, and mechanical environments.

The SR16/17 Series sensors contain an internal magnet and Hall effect sensor mounted in a twin tower configuration. In application, a customer supplied ferrous target passes between the tower gap, interrupts the magnetic field, and switches the digital state of the sensor.

These robust solid state Hall effect sensors are housed in an environmentally sealed plastic package. The Hall effect sensors provide highly accurate and repeatable performance in environments in which dirt, dust, or stray IR light might affect the performance of optical solutions. The sensor package is constructed of rugged polyphthalamide and polycarbonate material and is mechanically interchangeable with our standard optical sensors.

⚠ WARNING

PERSONAL INJURY

- DO NOT USE these products as safety or emergency stop devices, or in any other application where failure of the product could result in personal injury.

Failure to comply with these instructions could result in death or serious injury.

⚠ WARNING

MISUSE OF DOCUMENTATION

- The information presented in this product sheet is for reference only. Do not use this document as product installation information.
- Complete installation, operation, and maintenance information is provided in the instructions supplied with each product.

Failure to comply with these instructions could result in death or serious injury.

Solid State Sensors

SR16/17 Hall Effect Vane Sensors

SR16/17 Series

ELECTRICAL CHARACTERISTICS -20°C TO 85 °C, 3.8 TO 30 VDC

	Min.	Max.	Remarks
Supply voltage		3.8 to 30	VDC
Current consumption	—	9	mA (off) 10 mA (on)
Output voltage (operated)	—	0.40 V	Sinking 20 mA max.
Sink current (operated)	—	20	mA
Output leakage current (released)	—	10 μ A	V _{OUT} = 30 VDC, V _{CC} = 24 VDC
Output switching time			
Rise, 10 to 90%	—	1.5 μ s	V _{CC} = 12 V, R _L = 1.6 K Ω , C _L = 20 pF
Fall, 90 to 10%	—	1.5 μ s	V _{CC} = 12 V, R _L = 1.6 K Ω , C _L = 20 pF
Operating Temperature	-20°C to +85°C (-4°F to +185°F)		

MECHANICAL CHARACTERISTICS

Operating Range 12 VDC @ 25°C

Operate	Release
1.5° \pm 2.0°	3.0° \pm 2.5°

CONDITIONS

Target engagement distance 0.150 in to 0.300 in

RPMs 0 to 5000

Slot depth 0.250 in min.

BLOCK CIRCUIT WIRING DIAGRAM

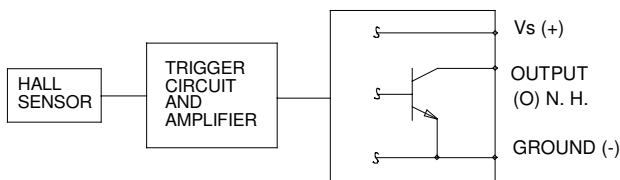

SPEED SENSING INTERFACE

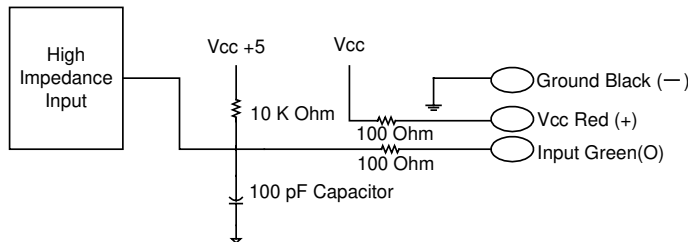

MOUNTING DIMENSIONS (for reference only) mm/in

SR16/17 Series Vane Sensors

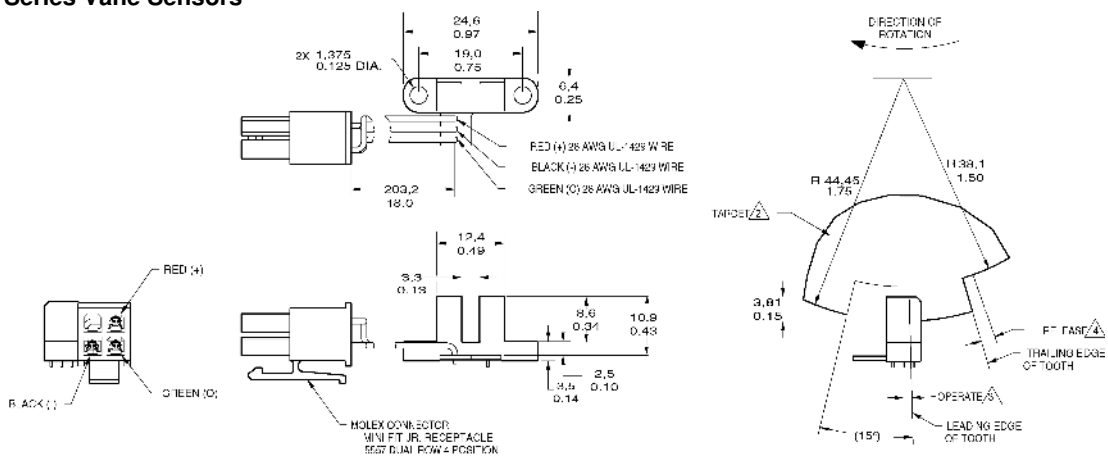

SR16C-J4

Solid State Sensors

SR16/17 Hall Effect Vane Sensors

SR16/17 Series

MOUNTING DIMENSIONS (for reference only) mm/in

SR16/17 Series Vane Sensors

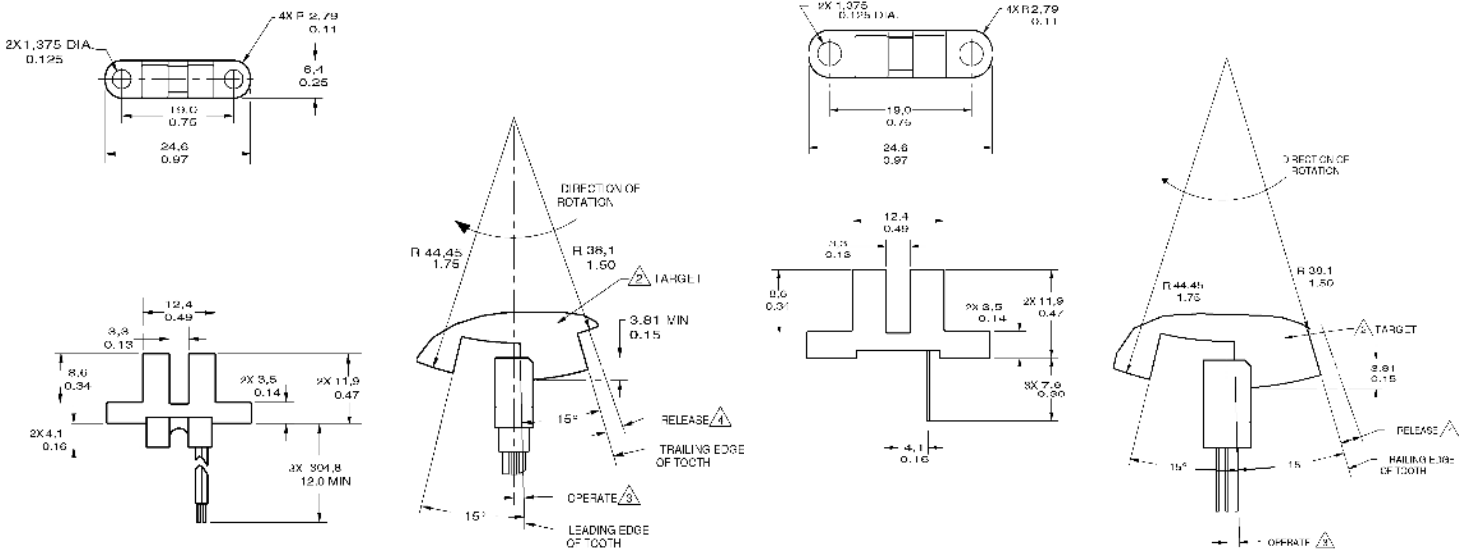

SR16C-J6

SR16C-N

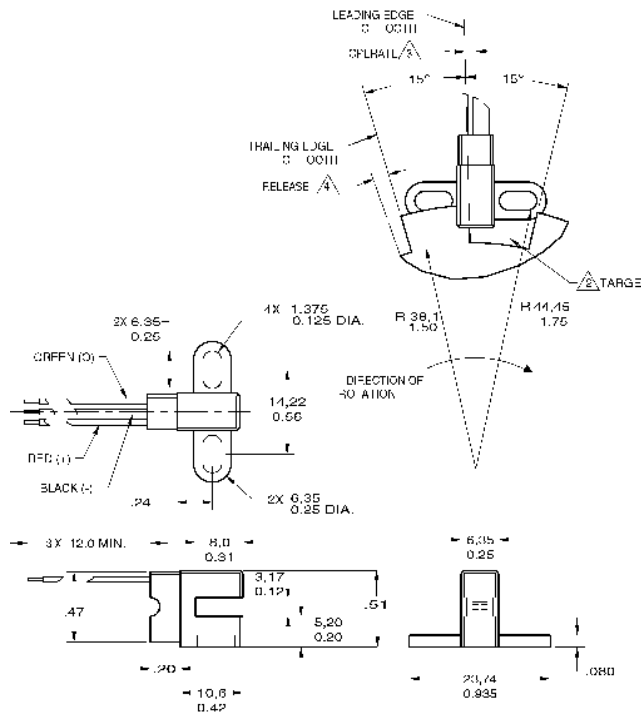

SR17C-J6

Notes:

1. Mounting specification: non-ferrous #4 machine head screws with .25 OD washers torqued to 3-5 in-lbs.
2. Suggested target configuration, material: .045 low carbon steel, high permeability, low residual induction.
3. Operate (degrees) is the angular distance from the leading edge of the tooth to the centerline of the sensor.
4. Release (degrees) is the angular distance from the trailing edge of the tooth to the centerline of the sensor.
5. Operating specification is based on target shown.

Solid State Sensors

SR16/17 Hall Effect Vane Sensors

SR16/17 Series

WARRANTY/REMEDY

Honeywell warrants goods of its manufacture as being free of defective materials and faulty workmanship. Contact your local sales office for warranty information. If warranted goods are returned to Honeywell during the period of coverage, Honeywell will repair or replace without charge those items it finds defective. The foregoing is Buyer's sole remedy and is **in lieu of all other warranties, expressed or implied, including those of merchantability and fitness for a particular purpose.**

Specifications may change without notice. The information we supply is believed to be accurate and reliable as of this printing. However, we assume no responsibility for its use.

While we provide application assistance personally, through our literature and the Honeywell web site, it is up to the customer to determine the suitability of the product in the application.

For application assistance, current specifications, or name of the nearest Authorized Distributor, contact a nearby sales office. Or call:

1-800-537-6945 USA

1-800-737-3360 Canada

1-815-235-6847 International

FAX

1-815-235-6545 USA

INTERNET

www.honeywell.com/sensing
info.sc@honeywell.com

Honeywell

Sensing and Control

Honeywell

11 West Spring Street

Freeport, Illinois 61032



Printed with Soy Ink
on 50% Recycled Paper

005844-1-EN IL50 GLO 0300 Printed in USA

www.honeywell.com/sensing