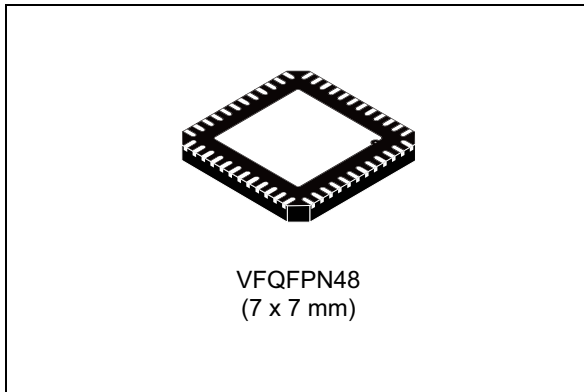

DMOS dual full bridge driver

Datasheet - production data

**Description**

The L6207Q device is a DMOS dual full bridge driver designed for motor control applications, realized in BCDmultipower technology, which combines isolated DMOS power transistors with CMOS and bipolar circuits on the same chip. The device also includes two independent constant OFF time PWM current controllers that perform the chopping regulation. Available in a VFQFPN48 7 x 7 package, the L6207Q device features thermal shutdown and a non-dissipative overcurrent detection on the high-side Power MOSFETs.

Features

- Operating supply voltage from 8 to 52 V
- 5.6 A output peak current
- $R_{DS(on)}$ 0.3 Ω typ. value at $T_j = 25\text{ }^\circ\text{C}$
- Operating frequency up to 100 kHz
- Non-dissipative overcurrent protection
- Dual independent constant t_{OFF} PWM current controllers
- Slow decay synchronous rectification
- Cross conduction protection
- Thermal shutdown
- Undervoltage lockout
- Integrated fast freewheeling diodes

Applications

- Bipolar stepper motor
- Dual or quad DC motor

Contents

1	Block diagram	3
2	Electrical data	4
	2.1 Absolute maximum ratings	4
	2.2 Recommended operating conditions	4
3	Pin connection	5
4	Electrical characteristics	7
5	Circuit description	10
	5.1 Power stages and charge pump	10
	5.2 Logic inputs	11
	5.3 PWM current control	12
	5.4 Slow decay mode	15
	5.5 Non-dissipative overcurrent detection and protection	16
	5.6 Thermal protection	18
6	Application information	19
7	Output current capability and IC power dissipation	21
8	Thermal management	22
9	Electrical characteristics curves	23
10	Package information	24
11	Order codes	26
12	Revision history	26

1 Block diagram

Figure 1. Block diagram

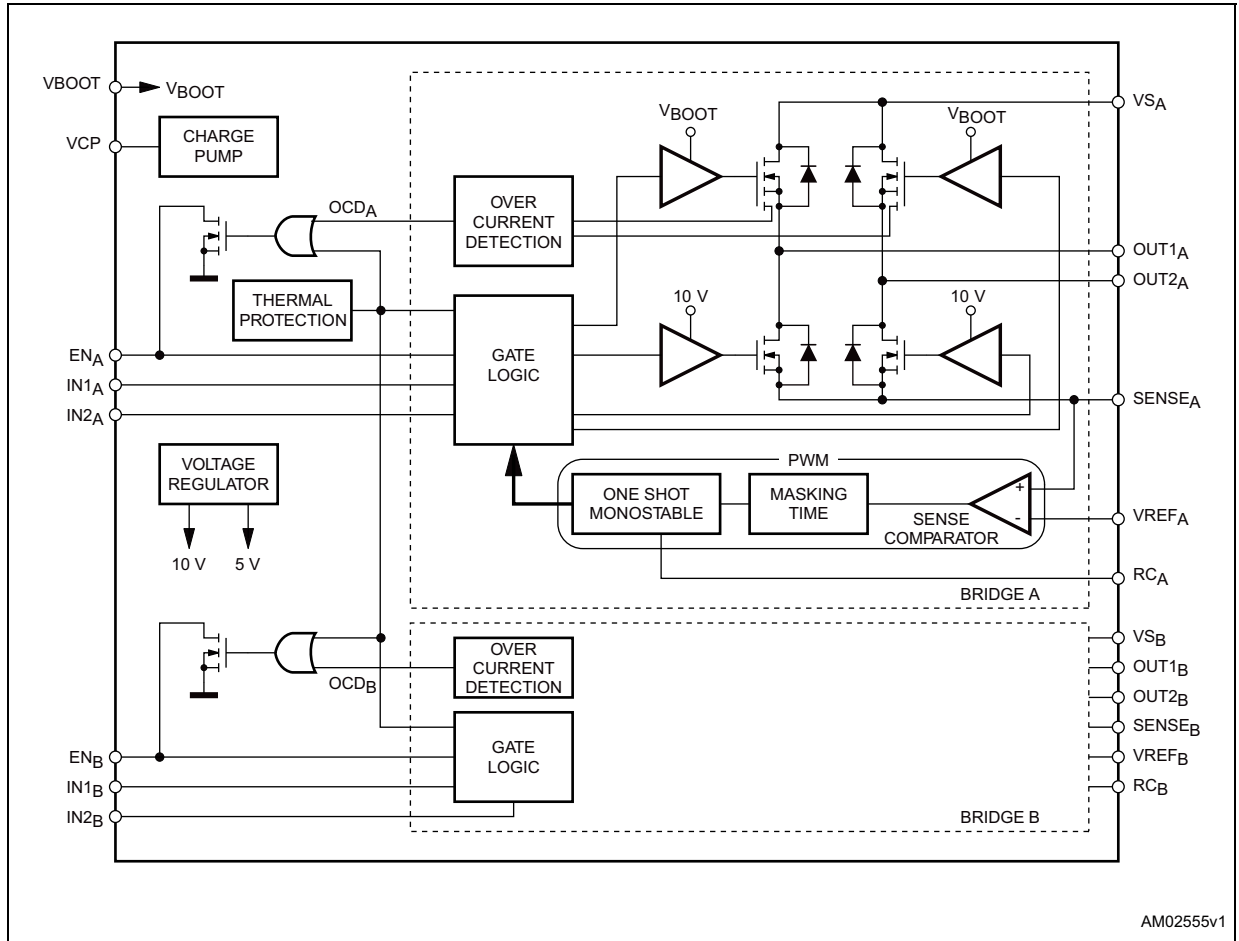

2 Electrical data

2.1 Absolute maximum ratings

Table 1. Absolute maximum ratings

Symbol	Parameter	Test condition	Value	Unit
V_S	Supply voltage	$V_{SA} = V_{SB} = V_S$	60	V
V_{OD}	Differential voltage between V_{SA} , $OUT1_A$, $OUT2_A$, $SENSE_A$ and V_{SB} , $OUT1_B$, $OUT2_B$, $SENSE_B$	$V_{SA} = V_{SB} = V_S = 60\text{ V}$; $V_{SENSE_A} = V_{SENSE_B} = \text{GND}$	60	V
V_{BOOT}	Bootstrap peak voltage	$V_{SA} = V_{SB} = V_S$	$V_S + 10$	V
V_{IN}, V_{EN}	Input and enable voltage range		-0.3 to +7	V
V_{REFA} , V_{REFB}	Voltage range at pins V_{REFA} and V_{REFB}		-0.3 to +7	V
V_{RCA}, V_{RCB}	Voltage range at pins RC_A and RC_B		-0.3 to +7	V
V_{SENSE_A} , V_{SENSE_B}	Voltage range at pins $SENSE_A$ and $SENSE_B$		-1 to +4	V
$I_{S(\text{peak})}$	Pulsed supply current (for each V_S pin), internally limited by the overcurrent protection	$V_{SA} = V_{SB} = V_S$; $t_{PULSE} < 1\text{ ms}$	7.1	A
I_S	RMS supply current (for each V_S pin)	$V_{SA} = V_{SB} = V_S$	2.5	A
T_{stg}, T_{OP}	Storage and operating temperature range		-40 to 150	°C

2.2 Recommended operating conditions

Table 2. Recommended operating conditions

Symbol	Parameter	Test condition	Min.	Max.	Unit
V_S	Supply voltage	$V_{SA} = V_{SB} = V_S$	8	52	V
V_{OD}	Differential voltage between V_{SA} , $OUT1_A$, $OUT2_A$, $SENSE_A$ and V_{SB} , $OUT1_B$, $OUT2_B$, $SENSE_B$	$V_{SA} = V_{SB} = V_S$; $V_{SENSE_A} = V_{SENSE_B}$		52	V
V_{SENSE_A} , V_{SENSE_B}	Voltage range at pins $SENSE_A$ and $SENSE_B$	Pulsed $t_W < t_{rr}$	-6	6	V
		DC	-1	1	V
I_{OUT}	RMS output current			2.5	A
T_j	Operating junction temperature		-25	+125	°C
f_{sw}	Switching frequency			100	kHz

3 Pin connection

Figure 2. Pin connection (top view)

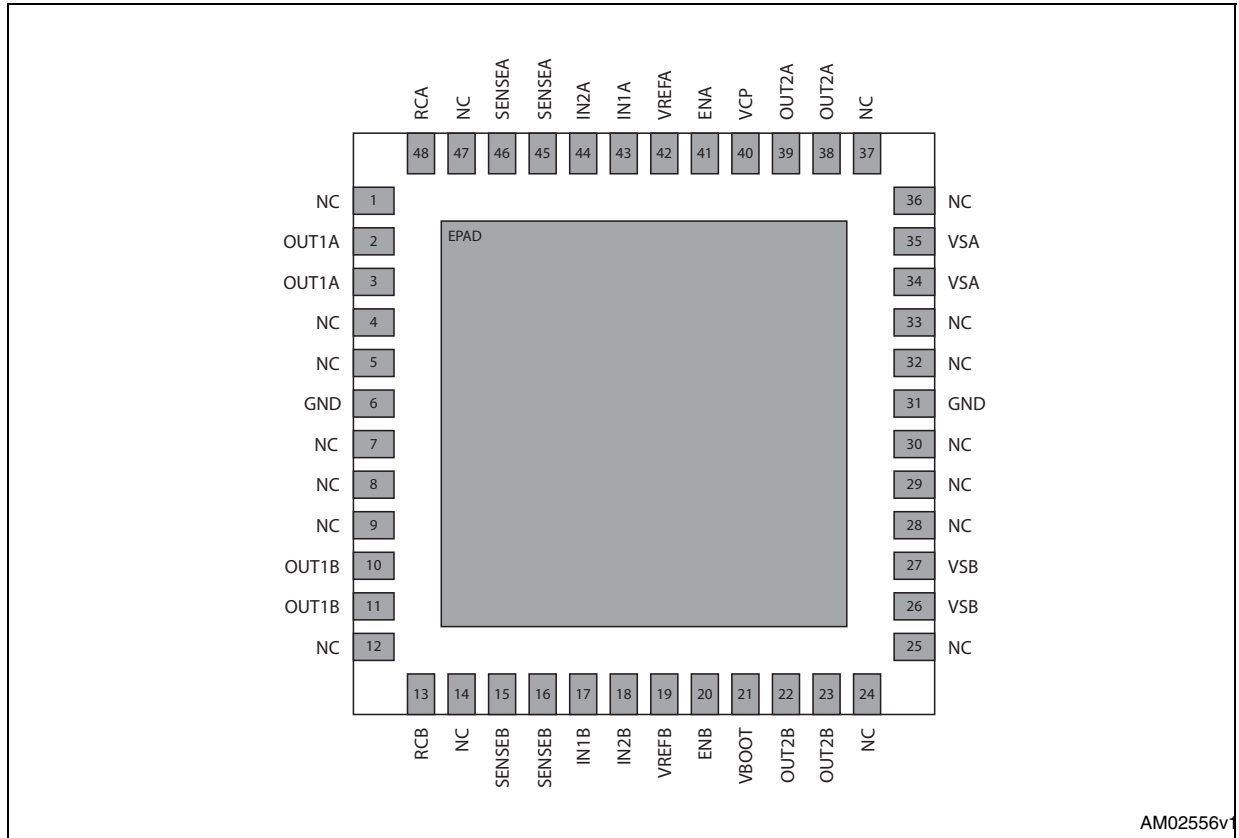

AM02556v1

Note: The exposed PAD must be connected to GND pin.

Table 3. Pin description

Pin	Name	Type	Function
43	IN1A	Logic input	Bridge A logic input 1.
44	IN2A	Logic input	Bridge A logic input 2.
45, 46	SENSEA	Power supply	Bridge A source pin. This pin must be connected to power ground through a sensing power resistor.
48	RCA	RC pin	RC network pin. A parallel RC network connected between this pin and ground sets the current controller OFF time of bridge A.
2, 3	OUT1A	Power output	Bridge A output 1.
6, 31	GND	GND	Signal ground terminals. These pins are also used for heat dissipation toward the PCB.
10, 11	OUT1B	Power output	Bridge B output 1.
13	RCB	RC pin	RC network pin. A parallel RC network connected between this pin and ground sets the current controller OFF time of bridge B.

Table 3. Pin description (continued)

Pin	Name	Type	Function
15, 16	SENSEB	Power supply	Bridge B source pin. This pin must be connected to power ground through a sensing power resistor.
17	IN1B	Logic input	Bridge B input 1
18	IN2B	Logic input	Bridge B input 2
19	VREFB	Analog input	Bridge B current controller reference voltage. Do not leave this pin open or connect to GND.
20	ENB	Logic input ⁽¹⁾	Bridge B enable. Low logic level switches off all power MOSFETs of Bridge B. This pin is also connected to the collector of the overcurrent and thermal protection transistor to implement overcurrent protection. If not used, it must be connected to +5 V through a resistor.
21	VBOOT	Supply voltage	Bootstrap voltage needed for driving the upper power MOSFETs of both Bridge A and bridge B.
22, 23	OUT2B	Power output	Bridge B output 2.
26, 27	VSB	Power supply	Bridge B power supply voltage. It must be connected to the supply voltage together with pin VSA.
34, 35	VSA	Power supply	Bridge A power supply voltage. It must be connected to the supply voltage together with pin VSB.
38, 39	OUT2A	Power output	Bridge A output 2.
40	VCP	Output	Charge pump oscillator output.
41	ENA	Logic input ⁽¹⁾	Bridge A enable. Low logic level switches off all power MOSFETs of bridge A. This pin is also connected to the collector of the overcurrent and transistor to implement overcurrent protection. If not used, it must be connected to +5 V through a resistor. Thermal protection
42	VREFA	Analog input	Bridge A current controller reference voltage. Do not leave this pin open or connect to GND.

1. Also connected at the output drain of the overcurrent and thermal protection MOSFET. Therefore, it must be driven putting in series a resistor with a value in the range of 2.2 k Ω - 180 k Ω , recommended 100 k Ω .

4 Electrical characteristics

$V_S = 48\text{ V}$, $T_A = 25\text{ °C}$, unless otherwise specified.

Table 4. Electrical characteristics

Symbol	Parameter	Test condition	Min.	Typ.	Max.	Unit
$V_{Sth(ON)}$	Turn-on threshold		6.6	7	7.4	V
$V_{Sth(OFF)}$	Turn-off threshold		5.6	6	6.4	V
I_S	Quiescent supply current	All bridges OFF; $T_j = -25\text{ °C}$ to $125\text{ °C}^{(1)}$		5	10	mA
$T_{j(OFF)}$	Thermal shutdown temperature			165		°C
Output DMOS transistors						
$R_{DS(ON)}$	High-side switch ON resistance	$T_j = 25\text{ °C}$		0.34	0.4	Ω
		$T_j = 125\text{ °C}^{(1)}$		0.53	0.59	
	Low-side switch ON resistance	$T_j = 25\text{ °C}$		0.28	0.34	
		$T_j = 125\text{ °C}^{(1)}$		0.47	0.53	
I_{DSS}	Leakage current	EN = low; OUT = V_S			2	mA
		EN = low; OUT = GND	-0.15			mA
Source drain diodes						
V_{SD}	Forward ON voltage	$I_{SD} = 2.5\text{ A}$, EN = low		1.15	1.3	V
t_{rr}	Reverse recovery time	$I_f = 2.5\text{ A}$		300		ns
t_{fr}	Forward recovery time			200		ns
Logic input						
V_{IL}	Low level logic input voltage		-0.3		0.8	V
V_{IH}	High level logic input voltage		2		7	V
I_{IL}	Low level logic input current	GND logic input voltage	-10			μA
I_{IH}	High level logic input current	7 V logic input voltage			10	μA
$V_{th(ON)}$	Turn-on input threshold			1.8	2	V
$V_{th(OFF)}$	Turn-off input threshold		0.8	1.3		V
$V_{th(HYS)}$	Input threshold hysteresis		0.25	0.5		V
Switching characteristics						
$t_{D(on)EN}$	Enable to out turn ON delay time ⁽²⁾	$I_{LOAD} = 2.5\text{ A}$, resistive load	100	250	400	ns
$t_{D(on)IN}$	Input to out turn ON delay time	$I_{LOAD} = 2.5\text{ A}$, resistive load (deadtime included)		1.6		μs
t_{RISE}	Output rise time ⁽²⁾	$I_{LOAD} = 2.5\text{ A}$, resistive load	40		250	ns
$t_{D(off)EN}$	Enable to out turn OFF delay time ⁽²⁾	$I_{LOAD} = 2.5\text{ A}$, resistive load	300	550	800	ns
$t_{D(off)IN}$	Input to out turn OFF delay time	$I_{LOAD} = 2.5\text{ A}$, resistive load		600		ns

Table 4. Electrical characteristics (continued)

Symbol	Parameter	Test condition	Min.	Typ.	Max.	Unit
t_{FALL}	Output fall time ⁽²⁾	$I_{LOAD} = 2.5 \text{ A}$, resistive load	40		250	ns
t_{DT}	Deadtime protection		0.5	1		μs
f_{CP}	Charge pump frequency	$-25 \text{ }^\circ\text{C} < T_j < 125 \text{ }^\circ\text{C}$		0.6	1	MHz
PWM comparator and monostable						
I_{RCA}, I_{RCB}	Source current at pins RCA and RCB	$V_{RCA} = V_{RCB} = 2.5 \text{ V}$	3.5	5.5		mA
V_{offset}	Offset voltage on sense comparator	$V_{REFA}, V_{REFB} = 0.5 \text{ V}$		± 5		mV
t_{PROP}	Turn OFF propagation delay ⁽³⁾			500		ns
t_{BLANK}	Internal blanking time on SENSE pins			1		μs
$t_{ON(MIN)}$	Minimum ON time			1.5	2	μs
t_{OFF}	PWM recirculation time	$R_{OFF} = 20 \text{ k}\Omega; C_{OFF} = 1 \text{ nF}$		13		μs
		$R_{OFF} = 100 \text{ k}\Omega; C_{OFF} = 1 \text{ nF}$		61		μs
I_{BIAS}	Input bias current at pins V_{REFA} and V_{REFB}				10	μA
Over current detection						
I_{sover}	Input supply overcurrent detection threshold	$-25 \text{ }^\circ\text{C} < T_j < 125 \text{ }^\circ\text{C}$	4	5.6	7.1	A
R_{OPDR}	Open drain ON resistance	$I = 4 \text{ mA}$		40	60	Ω
$t_{OCD(ON)}$	OCD turn-on delay time ⁽⁴⁾	$I = 4 \text{ mA}; C_{EN} < 100 \text{ pF}$		200		ns
$t_{OCD(OFF)}$	OCD turn-off delay time ⁽⁴⁾	$I = 4 \text{ mA}; C_{EN} < 100 \text{ pF}$		100		ns

1. Tested at 25 °C in a restricted range and guaranteed by characterization.

2. See [Figure 3](#).

3. Measured applying a voltage of 1 V to pin SENSE and a voltage drop from 2 V to 0 V to pin V_{REF} .

4. See [Figure 4](#).

Figure 3. Switching characteristic definition

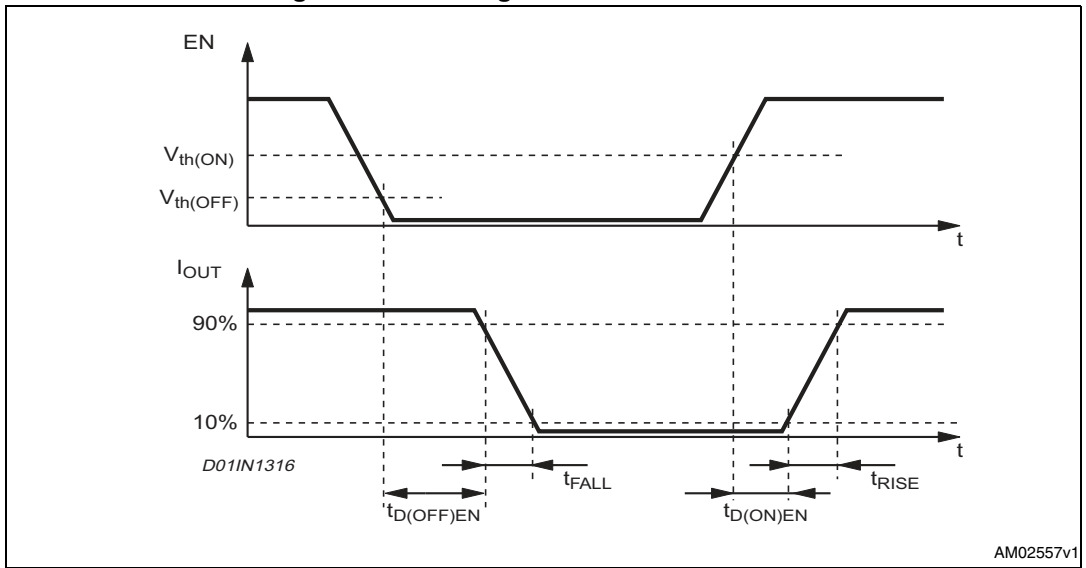
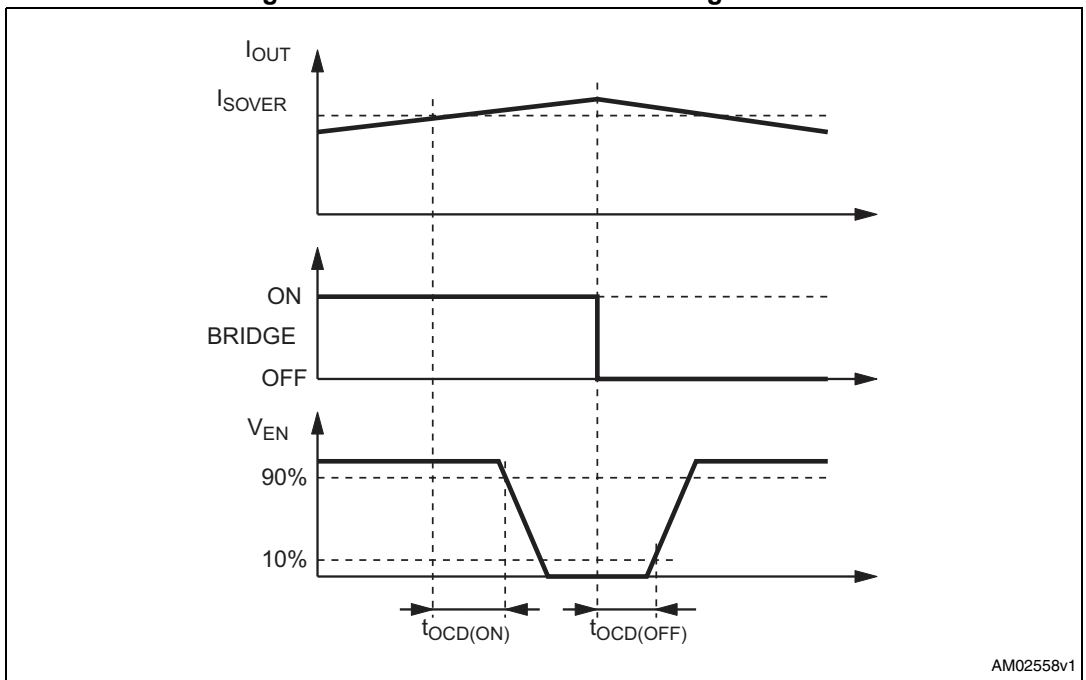

Figure 4. Overcurrent detection timing definition



5 Circuit description

5.1 Power stages and charge pump

The L6207Q device integrates two independent power MOSFET full bridges, each power MOSFET has an $R_{DS(ON)} = 0.3 \Omega$ (typical value at 25 °C) with intrinsic fast freewheeling diode. Cross conduction protection is implemented by using a deadtime ($t_{DT} = 1 \mu s$ typical value) set by internal timing circuit between the turn-off and turn-on of two power MOSFETs in one leg of a bridge.

Pins VS_A and VS_B must be connected together to the supply voltage (V_S).

Using an N-channel power MOSFET for the upper transistors in the bridge requires a gate drive voltage above the power supply voltage. The bootstrapped supply (V_{BOOT}) is obtained through an internal oscillator and a few external components to realize a charge pump circuit, as shown in [Figure 5](#). The oscillator output (pin VCP) is a square wave at 600 kHz (typically) with 10 V amplitude. Recommended values/part numbers for the charge pump circuit are shown in [Table 5](#).

Table 5. Charge pump external component values

Component	Value
C_{BOOT}	220 nF
C_P	10 nF
R_P	100 Ω
D1	1N4148
D2	1N4148

Figure 5. Charge pump circuit

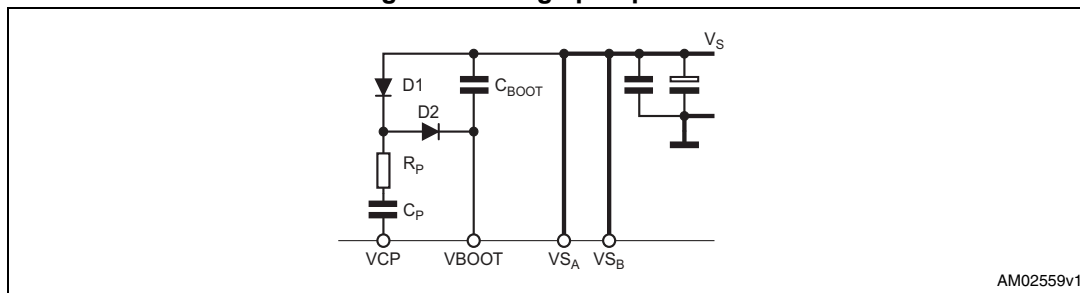

AM02559v1

5.2 Logic inputs

Pins IN1_A, IN2_A, IN1_B and IN2_B are TTL/CMOS and μC compatible logic inputs. The internal structure is shown in [Figure 6](#). Typical values for turn-on and turn-off thresholds are respectively $V_{\text{th(ON)}} = 1.8 \text{ V}$ and $V_{\text{th(OFF)}} = 1.3 \text{ V}$.

Pins EN_A and EN_B have identical input structures with the exception that the drains of the overcurrent and thermal protection MOSFETs (one for bridge A and one for bridge B) are also connected to these pins. Due to these connections, some care must be taken in driving these pins. Two configurations are shown in [Figure 7](#) and [8](#). If driven by an open drain (collector) structure, a pull-up resistor R_{EN} and a capacitor C_{EN} are connected, as shown in [Figure 7](#). If the driver is a standard push-pull structure, the resistor R_{EN} and the capacitor C_{EN} are connected, as shown in [Figure 8](#). The resistor R_{EN} should be chosen in the range from 2.2 k Ω to 180 k Ω . Recommended values for R_{EN} and C_{EN} are respectively 100 k Ω and 5.6 nF. More information on selecting the values is found in [Section 5.5](#).

Figure 6. Logic inputs internal structure

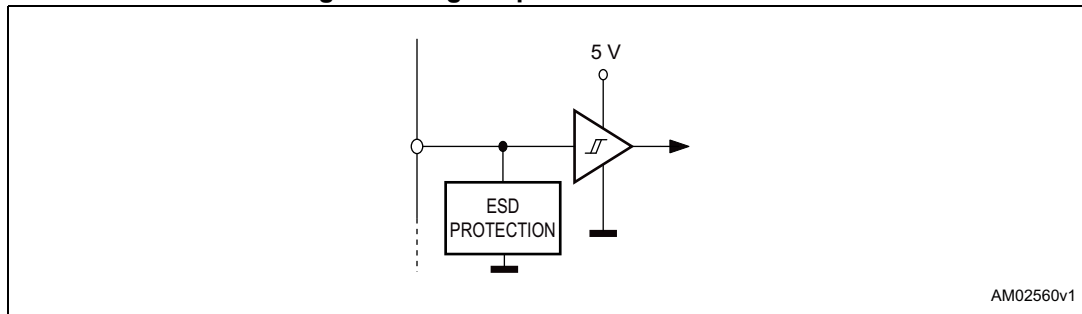

Figure 7. EN_A and EN_B pins open collector driving

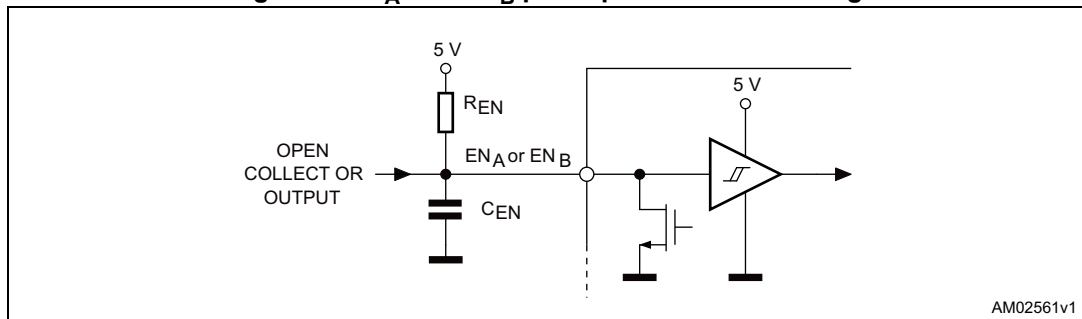

Figure 8. EN_A and EN_B pins push-pull driving

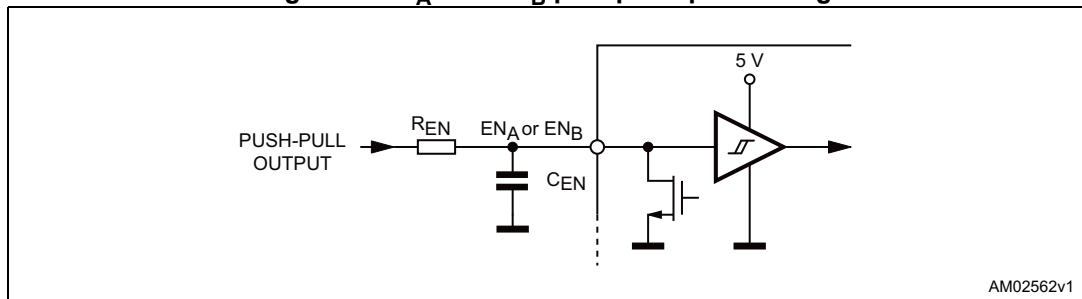

Table 6. Truth table

Inputs			Outputs		Description ⁽¹⁾
EN	IN1	IN2	OUT1	OUT2	
L	X ⁽²⁾	X	High Z ⁽³⁾	High Z	Disable
H	L	L	GND	GND	Brake mode (lower path)
H	H	L	V _S	GND (V _S) ⁽⁴⁾	Forward
H	L	H	GND (V _S)	V _S	Reverse
H	H	H	V _S	V _S	Brake mode (upper path)

1. Valid only in case of load connected between OUT1 and OUT2.
2. X = don't care.
3. High Z = high impedance output.
4. GND (V_S) = GND during t_{ON}, V_S during t_{OFF}.

5.3 PWM current control

The L6207Q device includes a constant OFF time PWM current controller for each of the two bridges. The current control circuit senses the bridge current by sensing the voltage drop across an external sense resistor connected between the source of the two lower power MOSFET transistors and ground, as shown in Figure 9. As the current in the load builds up, the voltage across the sense resistor increases proportionally. When the voltage drop across the sense resistor becomes greater than the voltage at the reference input (VREF_A or VREF_B), the sense comparator triggers the monostable switching the low-side MOSFET off. The low-side MOSFET remains off for the time set by the monostable and the motor current recirculates in the upper path. When the monostable times out, the bridge again turns on. As the internal deadtime, used to prevent cross conduction in the bridge, delays the turn-on of the power MOSFET, the effective OFF time is the sum of the monostable time plus the deadtime.

Figure 9. PWM current controller simplified schematic

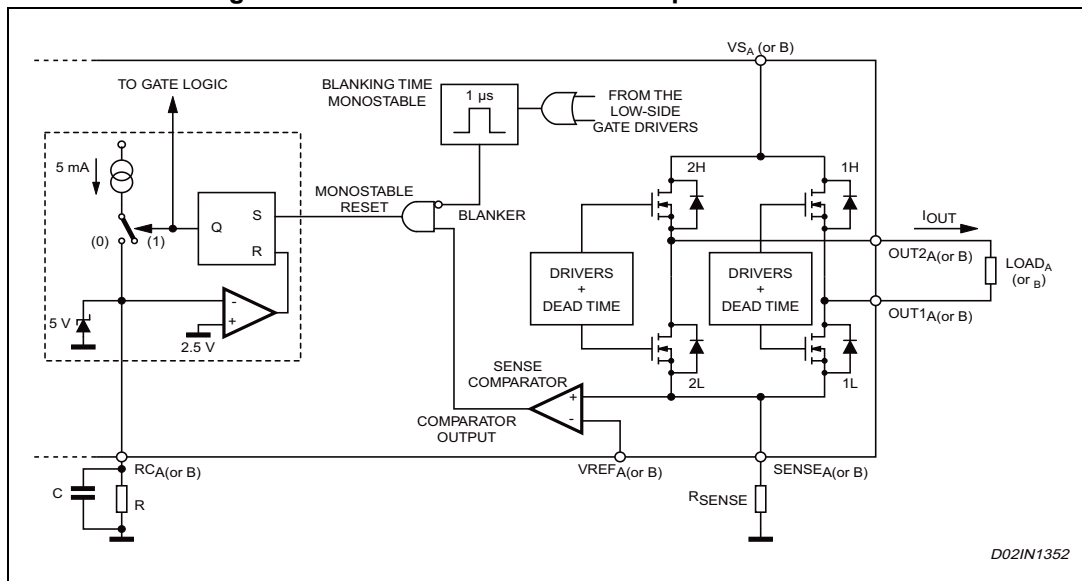

D02IN1352

Figure 10 shows the typical operating waveforms of the output current, the voltage drop across the sensing resistor, the RC pin voltage and the status of the bridge. Immediately after the low-side Power MOSFET turns on, a high peak current flows through the sensing resistor due to the reverse recovery of the freewheeling diodes. The L6207Q device provides a 1 μs blanking time t_{BLANK} that inhibits the comparator output so that this current spike cannot prematurely retrigger the monostable.

Figure 10. Output current regulation waveforms

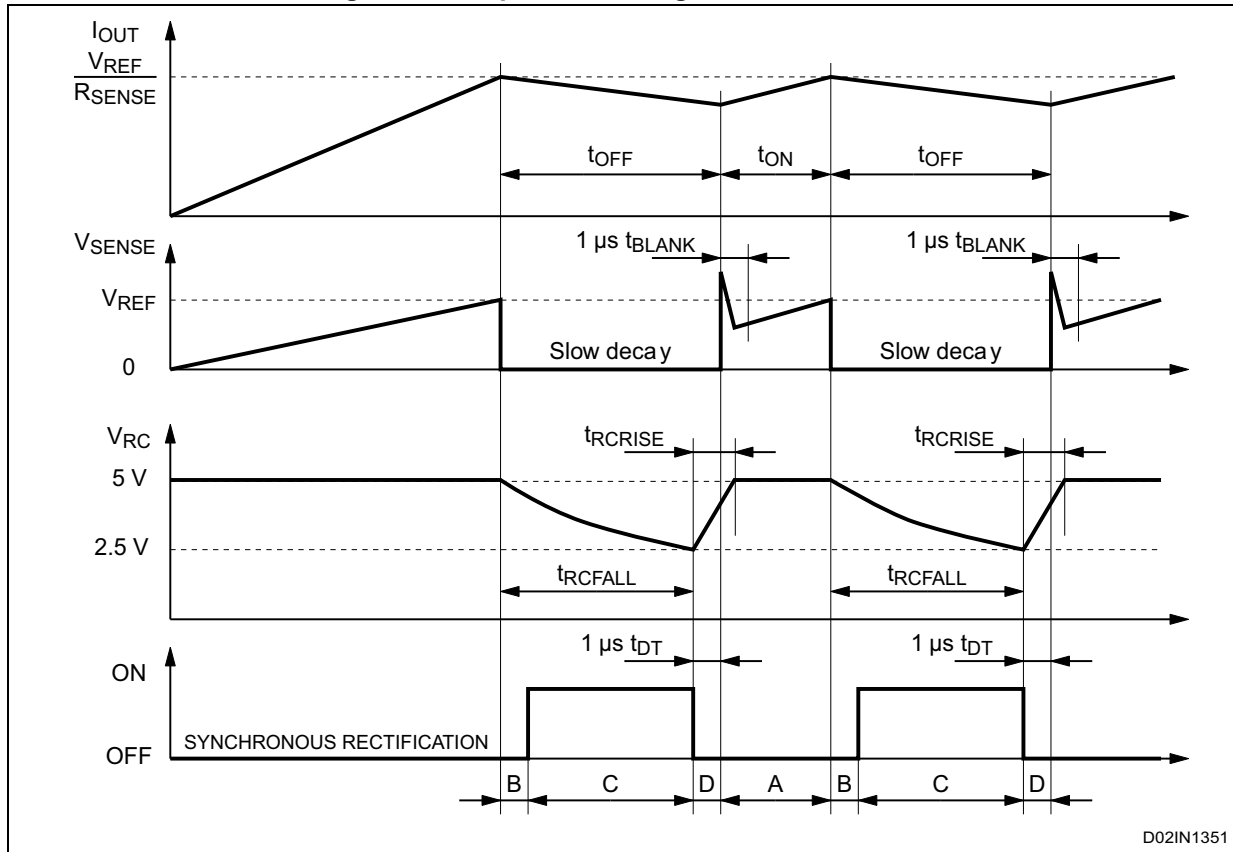

Figure 11 shows the magnitude of the OFF time t_{OFF} versus C_{OFF} and R_{OFF} values. It can be approximately calculated from *Equation 1* and *Equation 2*:

Equation 1

$$t_{RCFALL} = 0.6 \cdot R_{OFF} \cdot C_{OFF}$$

Equation 2

$$t_{OFF} = t_{RCFALL} + t_{DT} = 0.6 \cdot R_{OFF} \cdot C_{OFF} + t_{DT}$$

where R_{OFF} and C_{OFF} are the external component values and t_{DT} is the internally generated deadtime with:

Equation 3

$$20 \text{ k}\Omega \leq R_{OFF} \leq 100 \text{ k}\Omega$$

$$0.47 \text{ nF} \leq C_{OFF} \leq 100 \text{ nF}$$

$$t_{DT} = 1 \text{ }\mu\text{s (typical value)}$$

therefore:

Equation 4

$$t_{OFF(MIN)} = 6.6 \text{ }\mu\text{s}$$

$$t_{OFF(MAX)} = 6 \text{ ms}$$

These values allow a sufficient range of t_{OFF} to implement the drive circuit for most motors.

The capacitor value chosen for C_{OFF} also affects the rise time t_{RCRISE} of the voltage at the pin RC_{OFF} . The rise time t_{RCRISE} is only an issue if the capacitor is not completely charged before the next time the monostable is triggered. Therefore, the ON time t_{ON} , which depends on motors and supply parameters, must be bigger than t_{RCRISE} to allow a good current regulation by the PWM stage. Furthermore, the ON time t_{ON} can not be smaller than the minimum ON time $t_{ON(MIN)}$.

Equation 5

$$\left\{ \begin{array}{l} t_{ON} > t_{ON(MIN)} \\ t_{ON} > t_{RCRISE} - t_{DT} \end{array} \right. = 1,5\mu\text{s(typ)}$$

$$t_{RCRISE} = 600 \cdot C_{OFF}$$

Figure 12 shows the lower limit for the ON time t_{ON} for having a good PWM current regulation capacity. It should be mentioned that t_{ON} is always bigger than $t_{ON(MIN)}$ because the device imposes this condition, but it can be smaller than $t_{RCRISE} - t_{DT}$. In this last case the device continues to work but the OFF time t_{OFF} is not more constant.

Therefore, a small C_{OFF} value gives more flexibility to the applications (allows smaller ON time and, therefore, higher switching frequency), but, the smaller the value for C_{OFF} , the more influential the noises on the circuit performance.

Figure 11. t_{OFF} vs. C_{OFF} and R_{OFF}

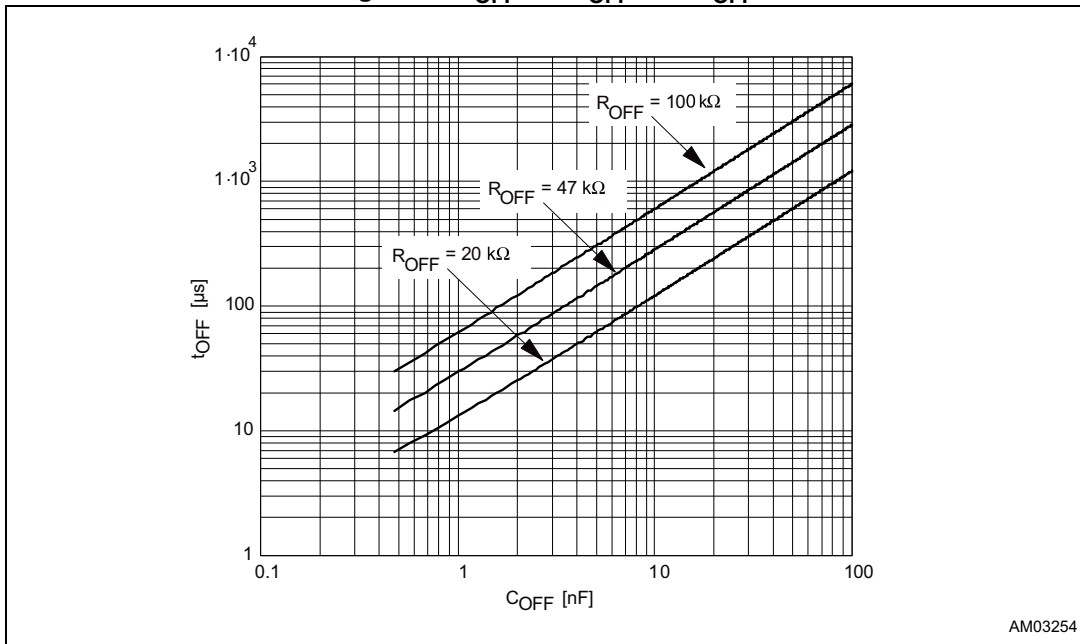

AM03254

Figure 12. Area where t_{ON} can vary maintaining the PWM regulation

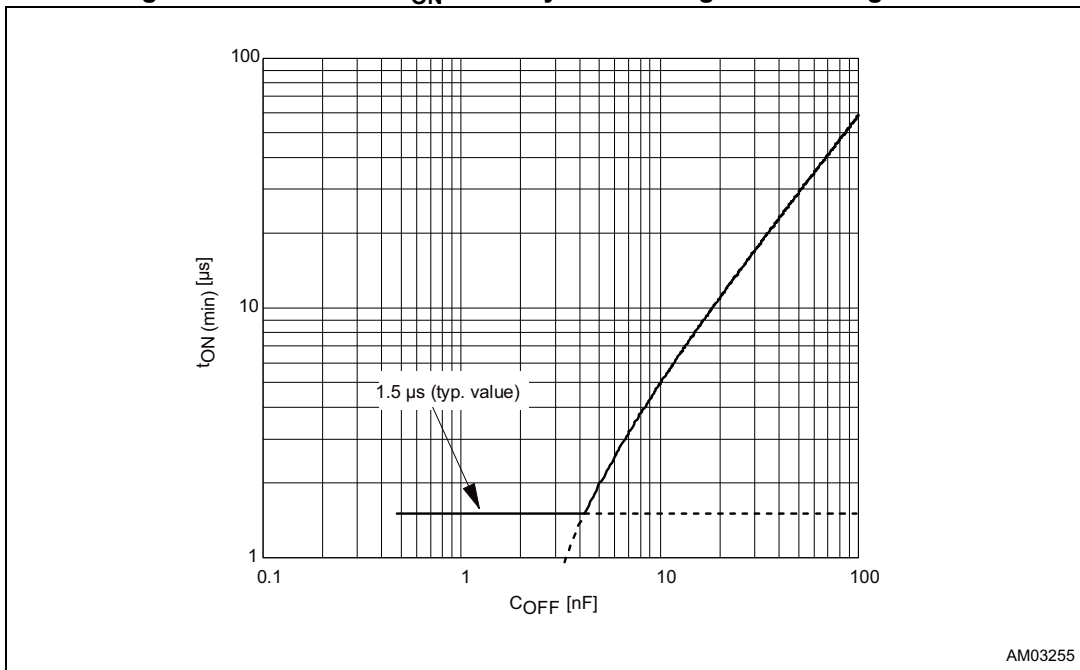

AM03255

5.4 Slow decay mode

Figure 13 shows the operation of the bridge in slow decay mode. At the start of the OFF time, the lower power MOSFET is switched off and the current recirculates around the upper half of the bridge. Since the voltage across the coil is low, the current decays slowly. After the deadtime the upper power MOSFET is operated in the synchronous rectification mode.

When the monostable times out, the lower power MOSFET is turned on again after some delay set by the deadtime to prevent cross conduction.

Figure 13. Slow decay mode output stage configurations

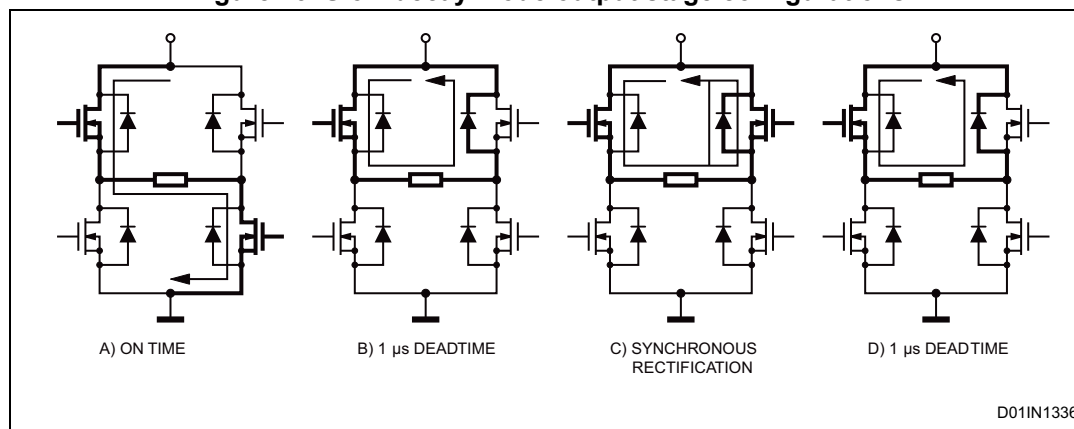

5.5 Non-dissipative overcurrent detection and protection

The L6207Q device integrates an overcurrent detection circuit (OCD).

With this internal overcurrent detection, the external current sense resistor normally used and its associated power dissipation are eliminated. [Figure 14](#) shows a simplified schematic of the overcurrent detection circuit for bridge A. Bridge B is provided by an analogous circuit.

To implement the overcurrent detection, a sensing element that delivers a small but precise fraction of the output current is implemented with each high-side power MOSFET. Since this current is a small fraction of the output current there is very little additional power dissipation. This current is compared with an internal reference current I_{REF} . When the output current reaches the detection threshold (typically 5.6 A) the OCD comparator signals a fault condition. When a fault condition is detected, an internal open drain MOSFET with a pull-down capability of 4 mA connected to the EN pin is turned on. [Figure 15](#) shows the OCD operation.

By using an external R-C on the EN pin, as shown in [Figure 14](#), the OFF time before recovering normal operation can be easily programmed by means of the accurate thresholds of the logic inputs.

The disable time $t_{DISABLE}$ before recovering normal operation can be easily programmed by means of the accurate thresholds of the logic inputs. It is affected by both C_{EN} and R_{EN} values and its magnitude is reported in [Figure 16](#). The delay time t_{DELAY} before turning off the bridge when an overcurrent has been detected depends only on the C_{EN} value. Its magnitude is reported in [Figure 17](#).

C_{EN} is also used for providing immunity to pin EN against fast transient noises. Therefore the value of C_{EN} should be chosen as big as possible according to the maximum tolerable delay time and the R_{EN} value should be chosen according to the desired disable time.

The resistor R_{EN} should be chosen in the range from 2.2 k Ω to 180 k Ω . Recommended values for R_{EN} and C_{EN} are respectively 100 k Ω and 5.6 nF which allow to obtain 200 μ s disable time.

Figure 14. Overcurrent protection simplified schematic

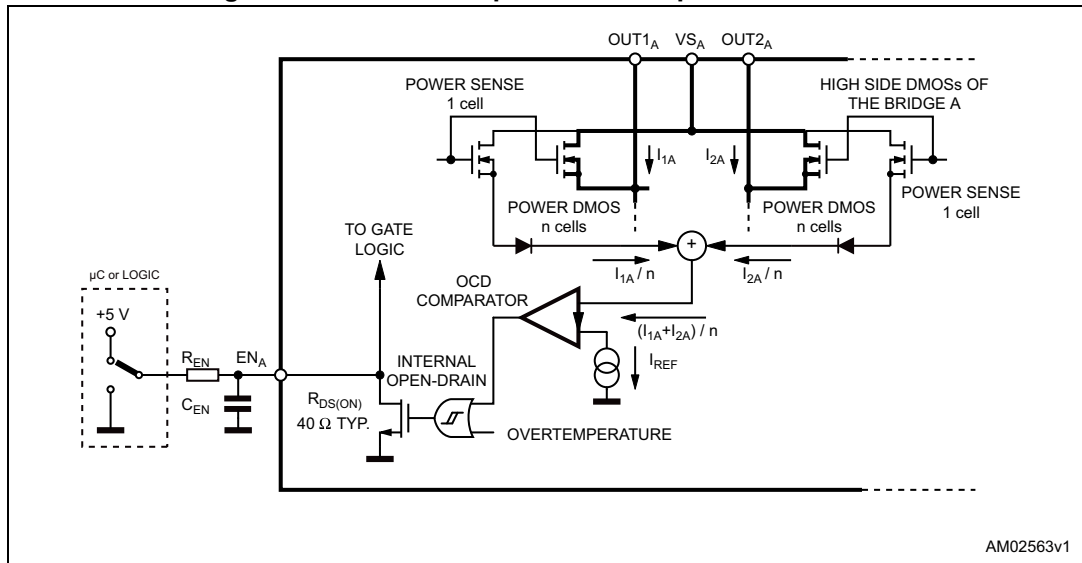

Figure 15. Overcurrent protection waveforms

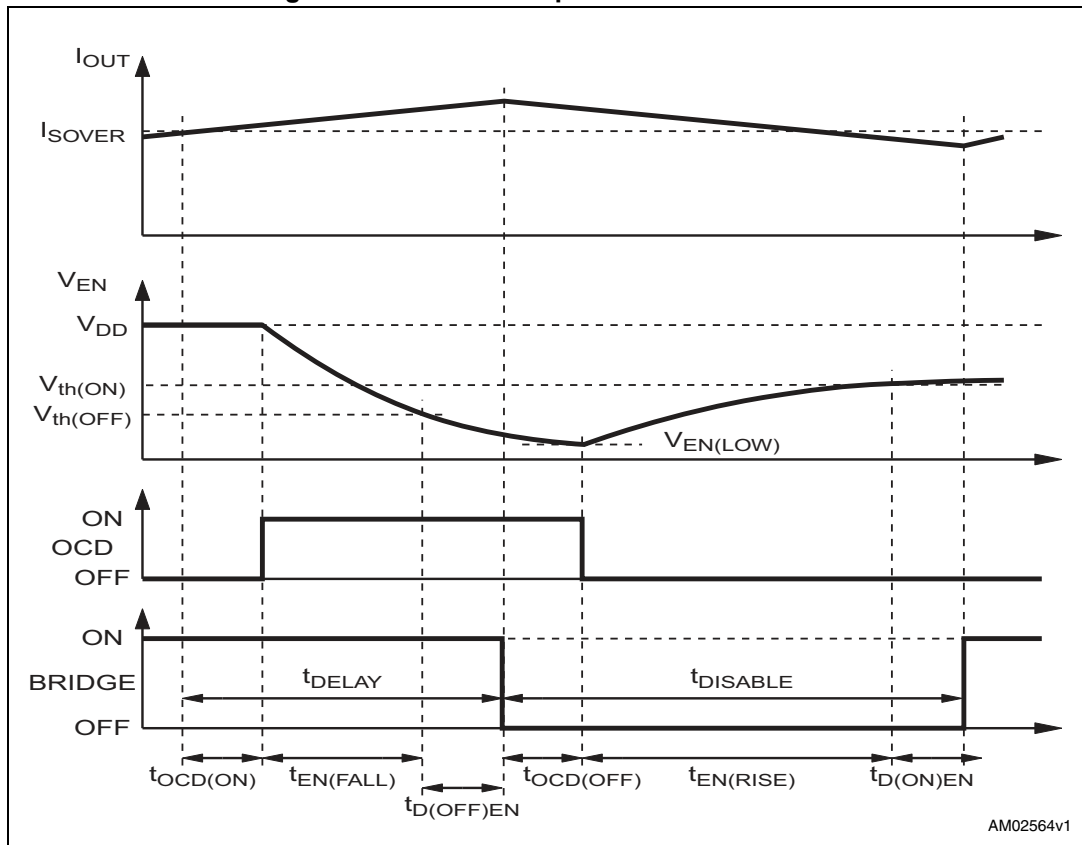

Figure 16. t_{DISABLE} vs. C_{EN} and R_{EN} ($V_{\text{DD}} = 5 \text{ V}$)

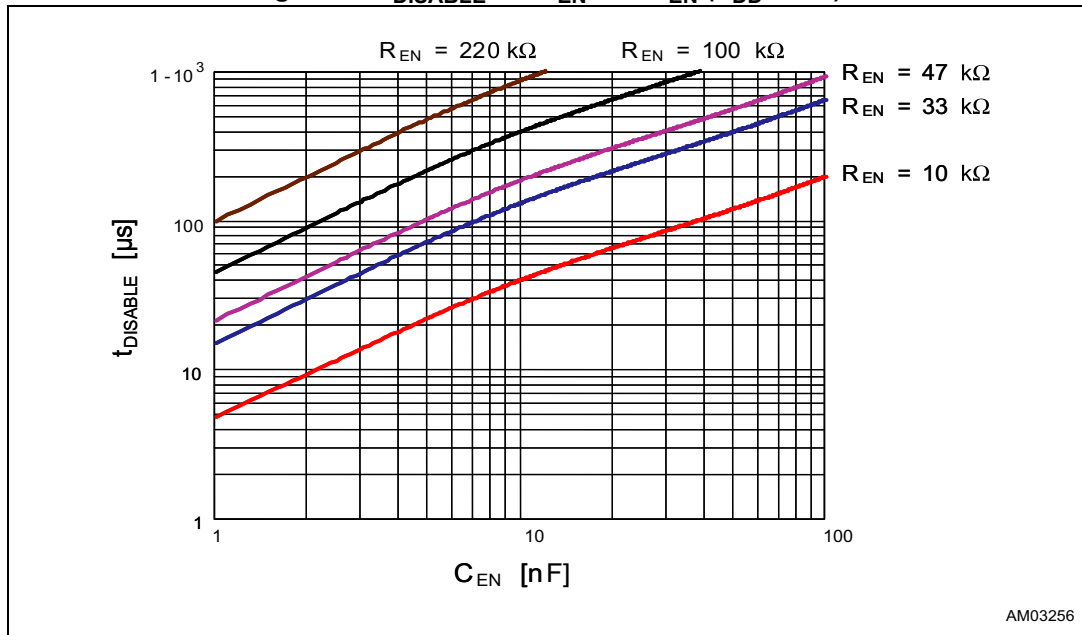
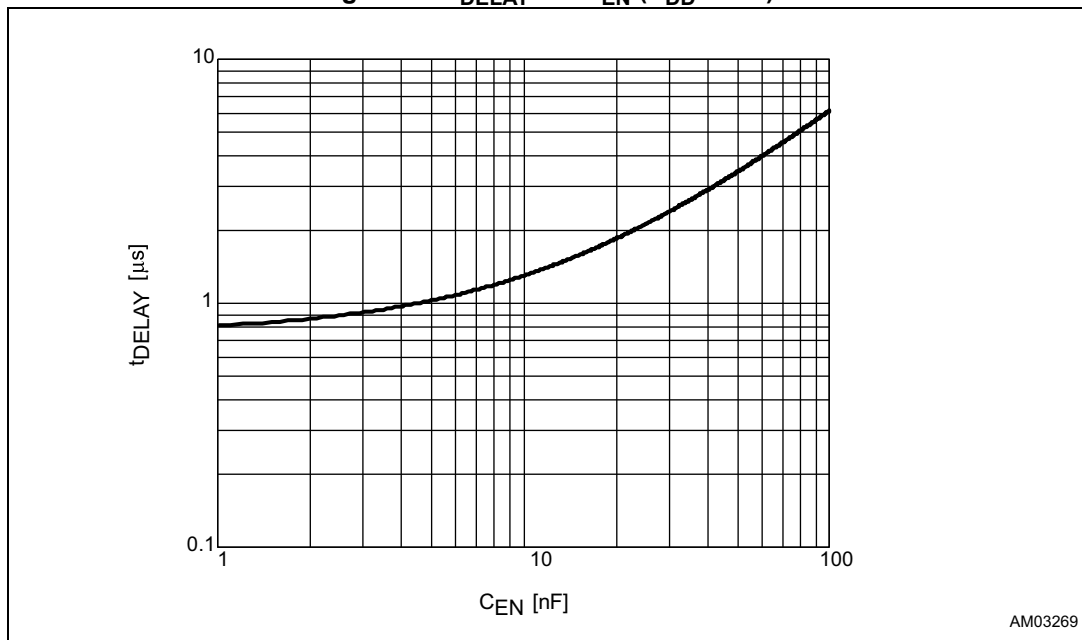

Figure 17. t_{DELAY} vs. C_{EN} ($V_{\text{DD}} = 5 \text{ V}$)



5.6 Thermal protection

In addition to the overcurrent detection, the L6207Q device integrates a thermal protection to prevent device destruction in the case of junction overtemperature. It works sensing the die temperature by means of a sensitive element integrated in the die. The device switches off when the junction temperature reaches 165 °C (typ. value) with 15 °C hysteresis (typ. value).

6 Application information

A typical application using the L6207Q device is shown in [Figure 18](#). Typical component values for the application are shown in [Table 7](#). A high quality ceramic capacitor in the range of 100 to 200 nF should be placed between the power pins (VS_A and VS_B) and ground near the L6207Q to improve the high frequency filtering on the power supply and reduce high frequency transients generated by the switching. The capacitors connected from the EN_A and EN_B inputs to ground set the shutdown time for bridge A and bridge B, respectively, when an overcurrent is detected (see [Section 5.5](#)). The two current sensing inputs ($SENSE_A$ and $SENSE_B$) should be connected to the sensing resistors with a trace length as short as possible in the layout. The sense resistors should be non-inductive resistors to minimize the di/dt transients across the resistor. To increase noise immunity, unused logic pins (except EN_A and EN_B) are best connected to 5 V (high logic level) or GND (low logic level) (see [Section 3](#)). It is recommended to keep power ground and signal ground separated on the PCB.

Table 7. Component values for typical application

Component	Value
C_1	100 μ F
C_2	100 nF
C_A	1 nF
C_B	1 nF
C_{BOOT}	220 nF
C_P	10 nF
C_{ENA}	5.6 nF
C_{ENB}	5.6 nF
C_{REFA}	68 nF
C_{REFB}	68 nF
D_1	1N4148
D_2	1N4148
R_A	39 k Ω
R_B	39 k Ω
R_{ENA}	100 k Ω
R_{ENB}	100 k Ω
R_P	100 Ω
R_{SENSEA}	0.3 Ω
R_{SENSEB}	0.3 Ω

Figure 18. Typical application

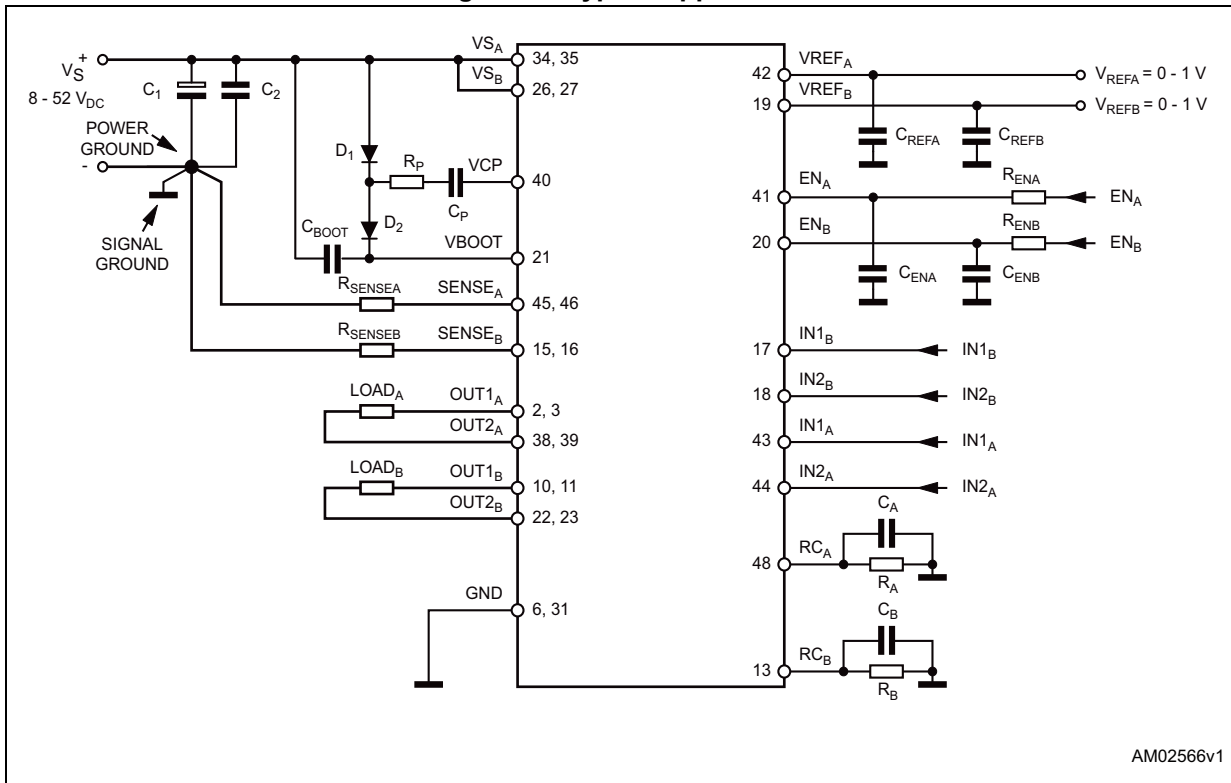

Note: To reduce the IC thermal resistance, therefore improving the dissipation path, the NC pins can be connected to GND.

7 Output current capability and IC power dissipation

Figure 19 and 20 show the approximate relation between the output current and the IC power dissipation using PWM current control driving two loads, for two different driving types:

- One full bridge ON at a time (Figure 19) in which only one load at a time is energized.
- Two full bridges ON at the same time (Figure 20) in which two loads are energized at the same time.

For a given output current and driving type the power dissipated by the IC can be easily evaluated, in order to establish which package should be used and how large the onboard copper dissipating area must be to guarantee a safe operating junction temperature (125 °C maximum).

Figure 19. IC power dissipation vs. output current with one full bridge ON at a time

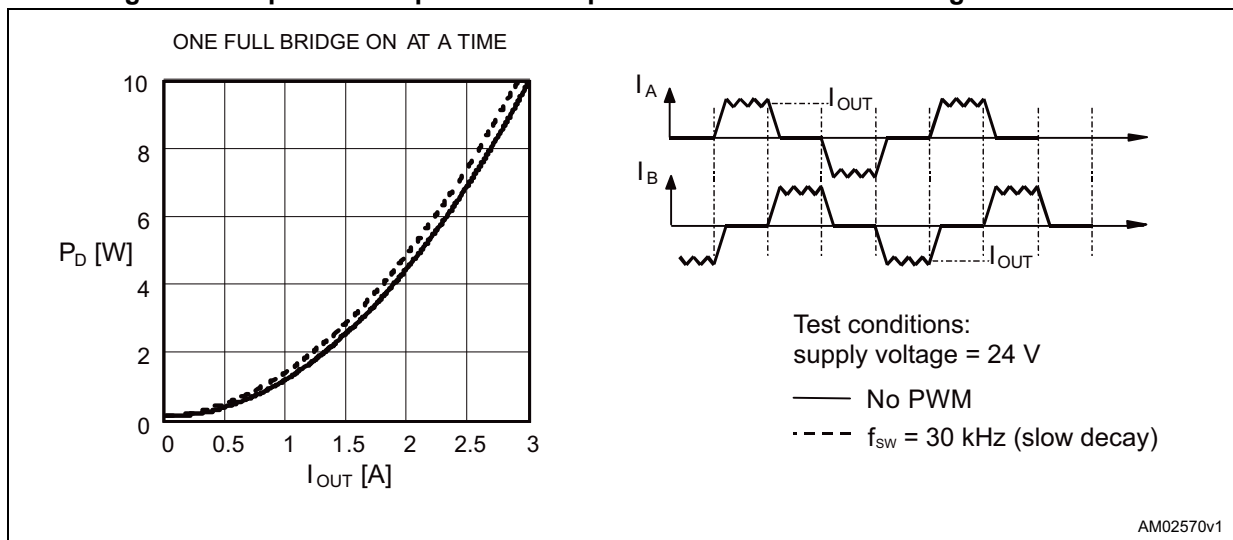
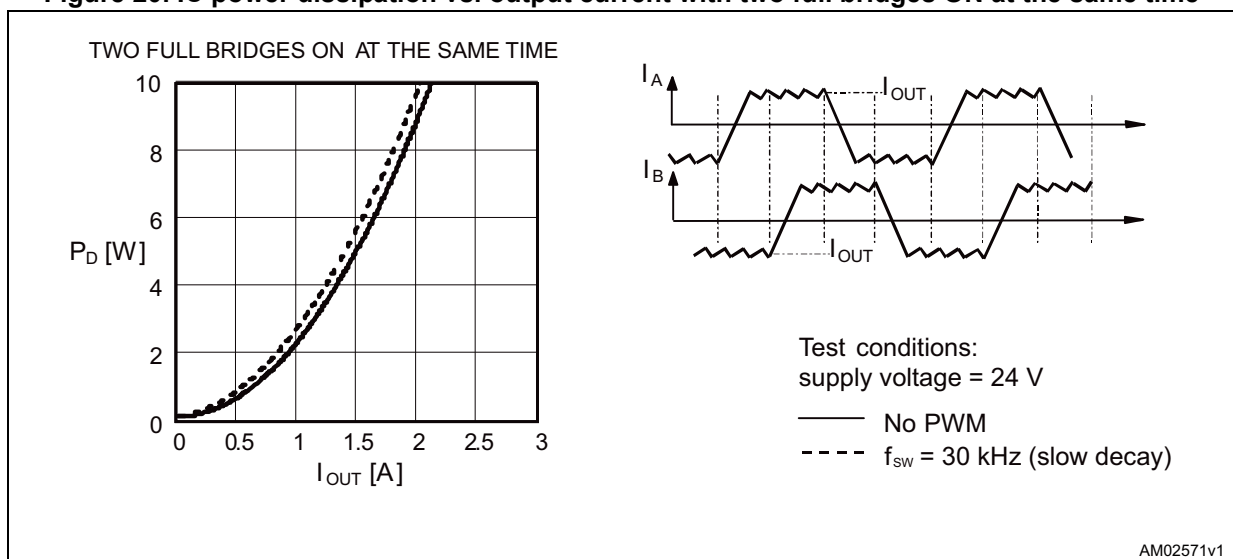

Figure 20. IC power dissipation vs. output current with two full bridges ON at the same time



8 Thermal management

In most applications the power dissipation in the IC is the main factor that sets the maximum current that can be delivered by the device in a safe operating condition. Therefore, it must be considered very carefully. Besides the available space on the PCB, the right package should be chosen considering the power dissipation. Heatsinking can be achieved using copper on the PCB with proper area and thickness.

Table 8. Thermal data

Symbol	Parameter	Package	Typ.	Unit
R_{thJA}	Thermal resistance junction-ambient	VFQFPN48 ⁽¹⁾	17	°C/W

1. VFQFPN48 mounted on EVAL6208Q rev 1 board (see EVAL6208Q databrief): four-layer FR4 PCB with a dissipating copper surface of about 45 cm² on each layer and 25 via holes below the IC.

9 Electrical characteristics curves

Figure 21. Typical quiescent current vs. supply voltage

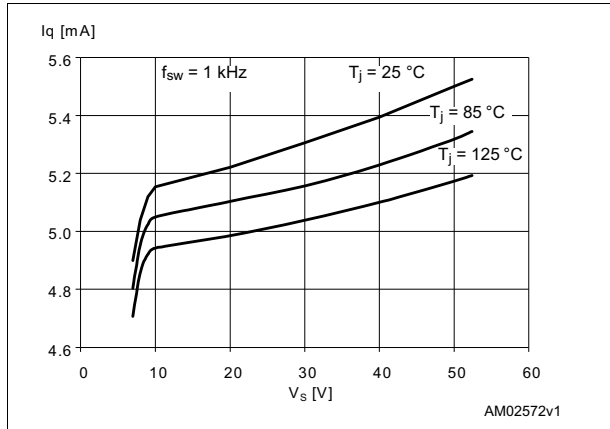

Figure 22. Typical high-side $R_{DS(on)}$ vs. supply voltage

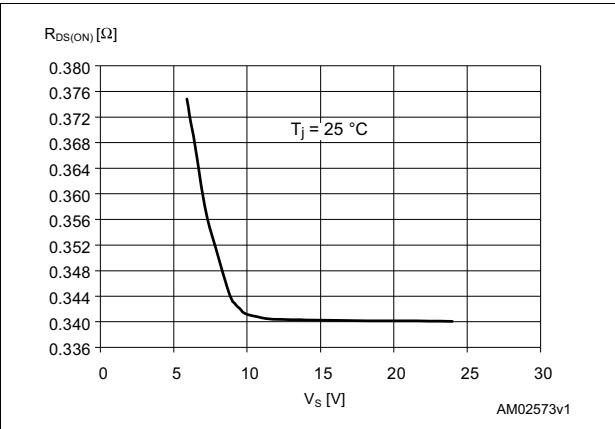

Figure 23. Normalized typical quiescent current vs. switching frequency

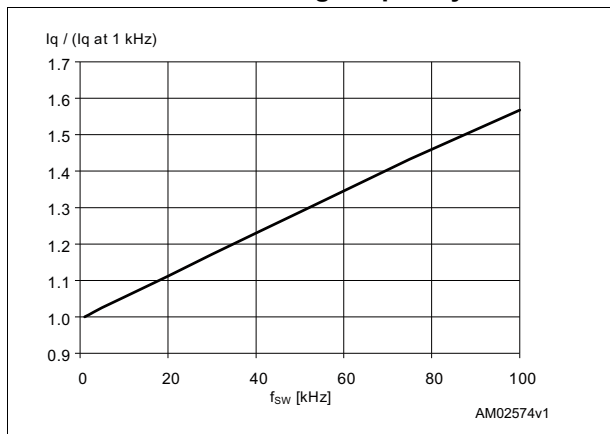

Figure 24. Normalized $R_{DS(on)}$ vs. junction temperature (typical value)

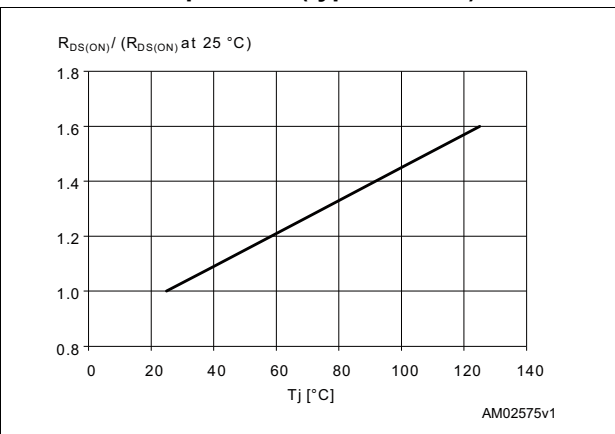

Figure 25. Typical low-side $R_{DS(on)}$ vs. supply voltage

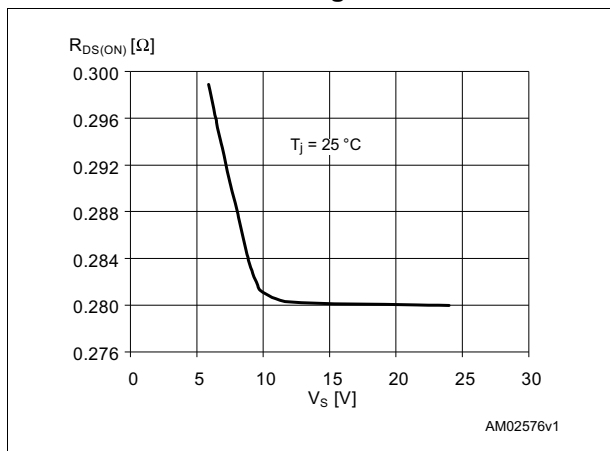
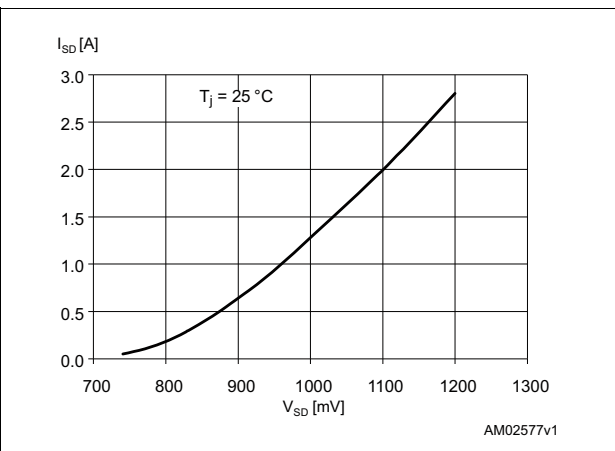

Figure 26. Typical drain-source diode forward ON characteristic



10 Package information

In order to meet environmental requirements, ST offers these devices in different grades of ECOPACK® packages, depending on their level of environmental compliance. ECOPACK specifications, grade definitions and product status are available at: www.st.com. ECOPACK is an ST trademark.

Figure 27. VFQFPN48 (7 x 7 x 1.0 mm) package outline

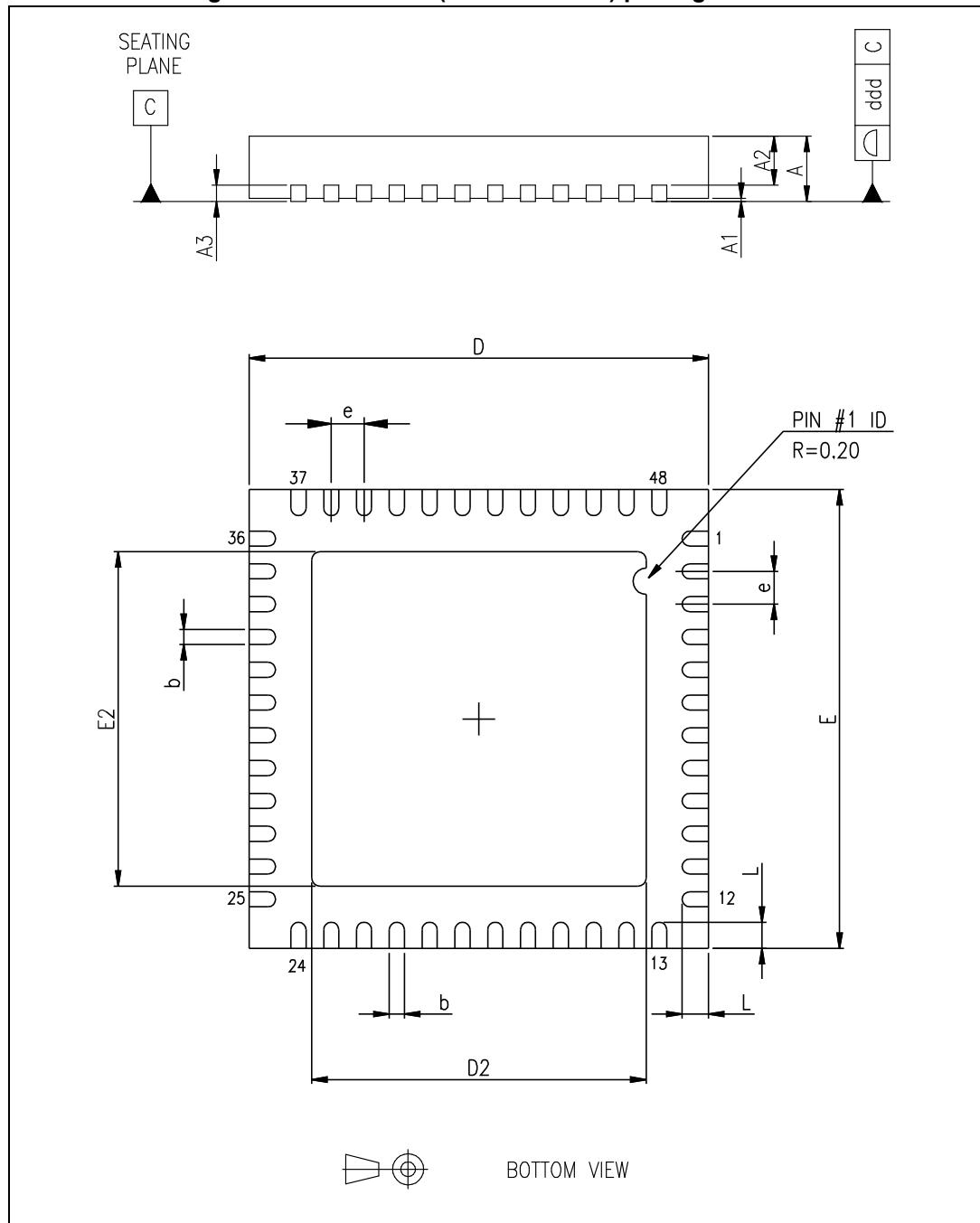

Table 9. VFQFPN48 (7 x 7 x 1.0 mm) package mechanical data

Symbol	Dimensions (mm)		
	Min.	Typ.	Max.
A	0.80	0.90	1.00
A1		0.02	0.05
A2		0.65	1.00
A3		0.25	
b	0.18	0.23	0.30
D	6.85	7.00	7.15
D2	4.95	5.10	5.25
E	6.85	7.00	7.15
E2	4.95	5.10	5.25
e	0.45	0.50	0.55
L	0.30	0.40	0.50
ddd		0.08	

11 Order codes

Table 10. Ordering information

Order codes	Package	Packaging
L6207Q	VFQFPN48 7x7x1.0 mm	Tray
L6207QTR		Tape and reel

12 Revision history

Table 11. Document revision history

Date	Revision	Changes
29-Jul-2011	1	First release
28-Nov-2011	2	Document moved from preliminary to final datasheet.
11-Jun-2013	3	<p>Unified package name to "VFQFPN48" in the whole document.</p> <p>Figure 1 moved to page 3, added Section 1: Block diagram.</p> <p>Corrected headings in Table 1 and Table 2 (replaced "Parameter" by "Test condition").</p> <p>Updated note 4. below Table 6 (replaced "t_{ON}" by "t_{OFF}").</p> <p>Corrected unit in Table 7 (row C₁).</p> <p>Added titles to Equation 1 to Equation 5 in Section 5.3: PWM current control.</p> <p>Added Table 8: Thermal data in Section 8: Thermal management.</p> <p>Updated Section 10: Package information (modified titles, reversed order of Figure 27 and Table 9).</p> <p>Unified "C_{EN}", "t_{DT}", "t_{ON}", "t_{OFF}", "C_{OFF}", "R_{OFF}", "V_{th(ON)}", "V_{th(OFF)}" (subscript, lower/upper case) in the whole document.</p> <p>Minor corrections throughout document.</p>

Please Read Carefully:

Information in this document is provided solely in connection with ST products. STMicroelectronics NV and its subsidiaries ("ST") reserve the right to make changes, corrections, modifications or improvements, to this document, and the products and services described herein at any time, without notice.

All ST products are sold pursuant to ST's terms and conditions of sale.

Purchasers are solely responsible for the choice, selection and use of the ST products and services described herein, and ST assumes no liability whatsoever relating to the choice, selection or use of the ST products and services described herein.

No license, express or implied, by estoppel or otherwise, to any intellectual property rights is granted under this document. If any part of this document refers to any third party products or services it shall not be deemed a license grant by ST for the use of such third party products or services, or any intellectual property contained therein or considered as a warranty covering the use in any manner whatsoever of such third party products or services or any intellectual property contained therein.

UNLESS OTHERWISE SET FORTH IN ST'S TERMS AND CONDITIONS OF SALE ST DISCLAIMS ANY EXPRESS OR IMPLIED WARRANTY WITH RESPECT TO THE USE AND/OR SALE OF ST PRODUCTS INCLUDING WITHOUT LIMITATION IMPLIED WARRANTIES OF MERCHANTABILITY, FITNESS FOR A PARTICULAR PURPOSE (AND THEIR EQUIVALENTS UNDER THE LAWS OF ANY JURISDICTION), OR INFRINGEMENT OF ANY PATENT, COPYRIGHT OR OTHER INTELLECTUAL PROPERTY RIGHT.

ST PRODUCTS ARE NOT AUTHORIZED FOR USE IN WEAPONS. NOR ARE ST PRODUCTS DESIGNED OR AUTHORIZED FOR USE IN: (A) SAFETY CRITICAL APPLICATIONS SUCH AS LIFE SUPPORTING, ACTIVE IMPLANTED DEVICES OR SYSTEMS WITH PRODUCT FUNCTIONAL SAFETY REQUIREMENTS; (B) AERONAUTIC APPLICATIONS; (C) AUTOMOTIVE APPLICATIONS OR ENVIRONMENTS, AND/OR (D) AEROSPACE APPLICATIONS OR ENVIRONMENTS. WHERE ST PRODUCTS ARE NOT DESIGNED FOR SUCH USE, THE PURCHASER SHALL USE PRODUCTS AT PURCHASER'S SOLE RISK, EVEN IF ST HAS BEEN INFORMED IN WRITING OF SUCH USAGE, UNLESS A PRODUCT IS EXPRESSLY DESIGNATED BY ST AS BEING INTENDED FOR "AUTOMOTIVE, AUTOMOTIVE SAFETY OR MEDICAL" INDUSTRY DOMAINS ACCORDING TO ST PRODUCT DESIGN SPECIFICATIONS. PRODUCTS FORMALLY ESCC, QML OR JAN QUALIFIED ARE DEEMED SUITABLE FOR USE IN AEROSPACE BY THE CORRESPONDING GOVERNMENTAL AGENCY.

Resale of ST products with provisions different from the statements and/or technical features set forth in this document shall immediately void any warranty granted by ST for the ST product or service described herein and shall not create or extend in any manner whatsoever, any liability of ST.

ST and the ST logo are trademarks or registered trademarks of ST in various countries.

Information in this document supersedes and replaces all information previously supplied.

The ST logo is a registered trademark of STMicroelectronics. All other names are the property of their respective owners.

© 2013 STMicroelectronics - All rights reserved

STMicroelectronics group of companies

Australia - Belgium - Brazil - Canada - China - Czech Republic - Finland - France - Germany - Hong Kong - India - Israel - Italy - Japan - Malaysia - Malta - Morocco - Philippines - Singapore - Spain - Sweden - Switzerland - United Kingdom - United States of America

www.st.com

