



Non-reversing motor starter Size 1 3/4 Three phase full voltage Solid-state overload relay OLRelay amp range 10-40a 24Vdc coil Combination type 40AMP circuit breaker Encl NEMA type 4X 316 S-steel Water/dust tight noncorrosive Standard width enclosure

product brand name	Class 18 & 26
design of the product	Full-voltage non-reversing motor starter with motor circuit protector
special product feature	ESP200 overload relay; Half-size controller
General technical data	
Height x Width x Depth [in]	24 × 11 × 8 in
touch protection against electrical shock	NA for enclosed products
installation altitude [ft] at height above sea level maximum	6560 ft
ambient temperature [°F]	
• during storage	-22 ... +149 °F
• during operation	-4 ... +104 °F
ambient temperature	
• during storage	-30 ... +65 °C
• during operation	-20 ... +40 °C
Horsepower ratings	
yielded mechanical performance [hp] for 3-phase AC motor	
• at 200/208 V rated value	0 hp
• at 220/230 V rated value	0 hp
• at 460/480 V rated value	15 hp
• at 575/600 V rated value	15 hp
Contactors	
size of contactor	Controller half size 1 3/4
number of NO contacts for main contacts	3
operating voltage for main current circuit at AC at 60 Hz maximum	600 V
operational current at AC at 600 V rated value	40 A
mechanical service life (operating cycles) of the main contacts typical	10000000
Auxiliary contact	
number of NC contacts at contactor for auxiliary contacts	0
number of NO contacts at contactor for auxiliary contacts	1
number of total auxiliary contacts maximum	8
contact rating of auxiliary contacts of contactor according to UL	10A@600VAC (A600), 5A@600VDC (P600)
Coil	
type of voltage of the control supply voltage	DC
control supply voltage	
• at DC rated value	24 V
holding power at AC minimum	0 W
apparent pick-up power of magnet coil at AC	163 VA
apparent holding power of magnet coil at AC	5.5 VA
operating range factor control supply voltage rated value of magnet coil	0.85 ... 1.1

percental drop-out voltage of magnet coil related to the input voltage	25 %
ON-delay time	21 ... 21 ms
OFF-delay time	11 ... 11 ms
Overload relay	
reset function	Manual, automatic and remote
trip class	CLASS 5 / 10 / 20 (factory set) / 30
adjustable current response value current of the current-dependent overload release	10 ... 40 A
make time with automatic start after power failure maximum	3 s
relative repeat accuracy	1 %
number of NC contacts of auxiliary contacts of overload relay	1
number of NO contacts of auxiliary contacts of overload relay	1
operational current of auxiliary contacts of overload relay <ul style="list-style-type: none"> • at AC at 600 V • at DC at 250 V 	5 A 1 A
contact rating of auxiliary contacts of overload relay according to UL	5A@600VAC (B600), 1A@250VDC (R300)
insulation voltage (Ui) <ul style="list-style-type: none"> • with single-phase operation at AC rated value • with multi-phase operation at AC rated value 	600 V 300 V
Enclosure	
design of the housing	dustproof, waterproof & resistant to corrosion
Circuit Breaker	
type of the motor protection	Motor circuit protector (magnetic trip only)
operational current of motor circuit breaker rated value	40 A
adjustable current response value current of instantaneous short-circuit trip unit	115 ... 375 A
Mounting/wiring	
mounting position	Vertical
fastening method	Surface mounting and installation
type of electrical connection for supply voltage line-side	Box lug
type of connectable conductor cross-sections at line-side for AWG cables single or multi-stranded	1x (10 AWG ... 1/0 AWG)
temperature of the conductor for supply maximum permissible	75 °C
material of the conductor for supply	AL or CU
type of electrical connection for load-side outgoing feeder	Screw-type terminals
tightening torque [lbf-in] for load-side outgoing feeder	45 ... 45 lbf-in
type of connectable conductor cross-sections for AWG cables for load-side outgoing feeder single or multi-stranded	1x (14 ... 2 AWG)
temperature of the conductor for load-side outgoing feeder maximum permissible	75 °C
material of the conductor for load-side outgoing feeder	AL or CU
type of electrical connection of magnet coil	Screw-type terminals
tightening torque [lbf-in] at magnet coil	5 ... 12 lbf-in
type of connectable conductor cross-sections of magnet coil for AWG cables single or multi-stranded	2x (16 ... 12 AWG)
temperature of the conductor at magnet coil maximum permissible	75 °C
material of the conductor at magnet coil	CU
type of electrical connection for auxiliary contacts	Screw-type terminals
tightening torque [lbf-in] at contactor for auxiliary contacts	10 ... 15 lbf-in
type of connectable conductor cross-sections at contactor for AWG cables for auxiliary contacts single or multi-stranded	1x (12 AWG), 2x (16 ... 14 AWG), 2x (18 ... 16 AWG)
temperature of the conductor at contactor for auxiliary contacts maximum permissible	75 °C
material of the conductor at contactor for auxiliary contacts	CU
type of electrical connection at overload relay for auxiliary contacts	Screw-type terminals
tightening torque [lbf-in] at overload relay for auxiliary contacts	7 ... 10 lbf-in
type of connectable conductor cross-sections at overload relay for AWG cables for auxiliary contacts single or multi-stranded	2x (20 ... 14 AWG)
temperature of the conductor at overload relay for auxiliary contacts maximum permissible	75 °C
material of the conductor at overload relay for auxiliary contacts	CU

Short-circuit current rating

design of the short-circuit trip	Instantaneous trip circuit breaker
maximum short-circuit current breaking capacity (I _{cu})	
<ul style="list-style-type: none"> • at 240 V • at 480 V • at 600 V 	100 kA 100 kA 25 kA
certificate of suitability	NEMA ICS 2; UL 508; CSA 22.2, No. 14

Further information

Industrial Controls - Product Overview (Catalogs, Brochures,...)

www.usa.siemens.com/iccatalog

Industry Mall (Online ordering system)

<https://mall.industry.siemens.com/mall/en/us/Catalog/product?mlfb=US2:18EUE92XS>

Service&Support (Manuals, Certificates, Characteristics, FAQs,...)

<https://support.industry.siemens.com/cs/US/en/ps/US2:18EUE92XS>

Image database (product images, 2D dimension drawings, 3D models, device circuit diagrams, EPLAN macros, ...)

http://www.automation.siemens.com/bilddb/cax_de.aspx?mlfb=US2:18EUE92XS&lang=en

Certificates/approvals

<https://support.industry.siemens.com/cs/US/en/ps/US2:18EUE92XS/certificate>

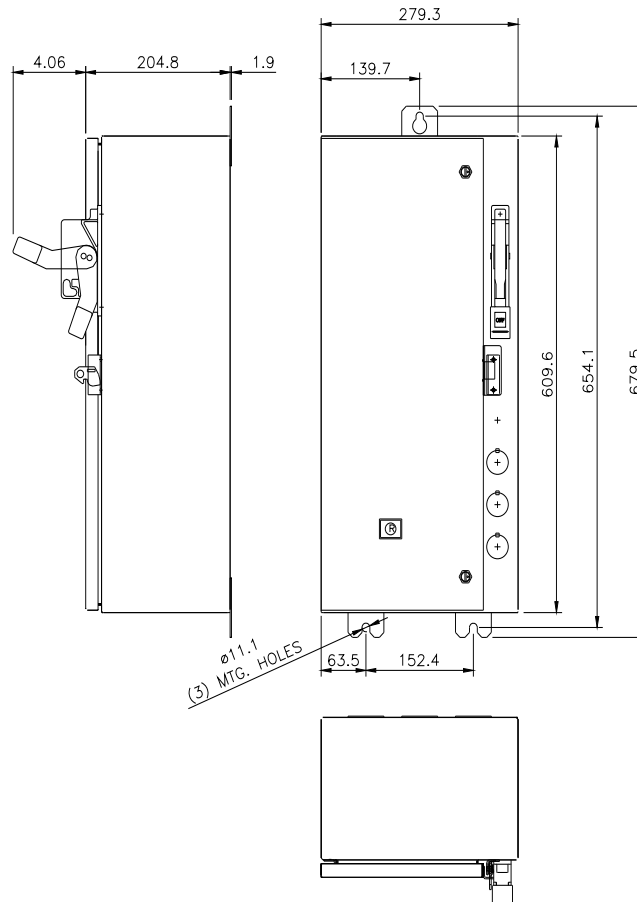

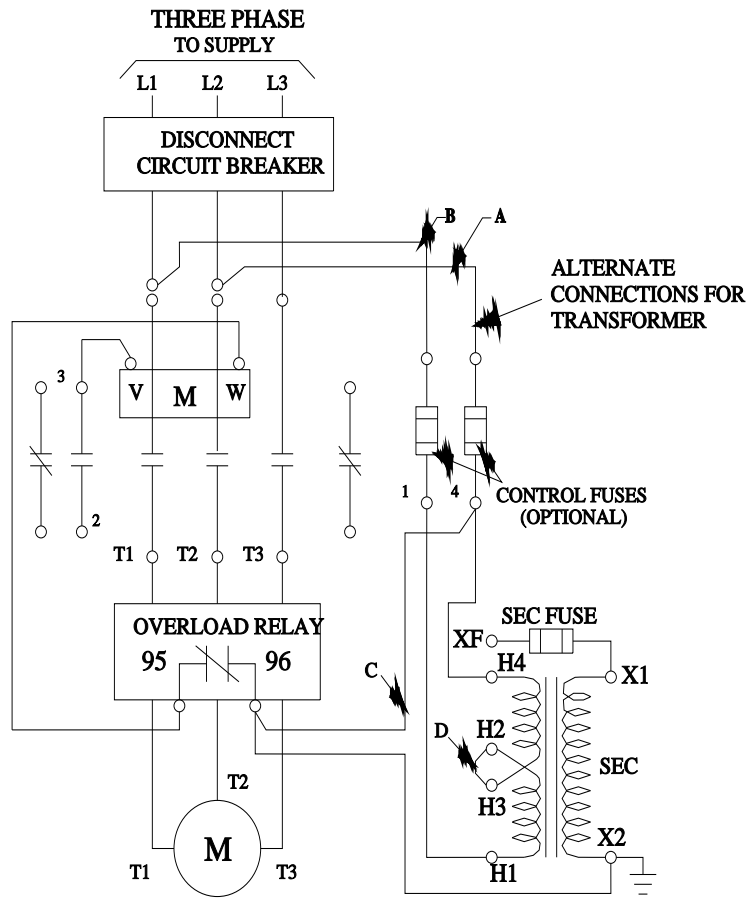

last modified:

1/25/2022