

Description

Microsemi's™ PoE controller, the PD69000 is a cost-effective, pre-programmed unit with an application used to implement Enhanced mode. It is used in conjunction with Microsemi's PoE Managers PD69012 and PD69008 in Ethernet switches to allow next generation network devices to share power and data over the same cable, as specified in the IEEE standard 802.3af and the IEEE802.3at-draft2.0. When used in conjunction with the PD69000, the PD69012/PD69008 operate in Enhanced mode, which allows the user to operate in a total Power-over-Ethernet stand-alone mode.

The controller features an ESPI bus for each of the PoE devices and a communication interface with the Host CPU via UART or I²C protocol.

The device is based on Freescale's MC9S08 MCUs family. It includes an asynchronous serial communications interface, a serial peripheral interface and a dual 2-channel, 16 bit timer. In addition, it includes an 8-channel 10-bit analog-to-digital converter.

Pin Configuration

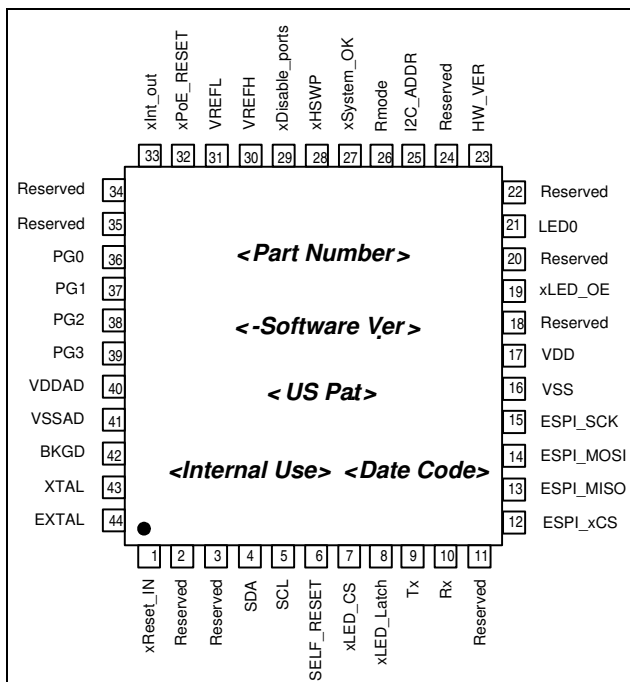

Marking Definitions

The label on the device includes the following:

- ◆ **<Part number>** Hardware P/N (e.g. PD69000)
- ◆ **<Software Ver>** software version (e.g. 0120)
- ◆ **<US Pat>** USA patent number of Microsemi
- ◆ **<Internal Use>** factory Internal Use
- ◆ **<Date Code>** Burning date code in the following format: yyww (yy = year, ww = week)

Supported Features

- ◆ Controls up to 96 PoE ports (8 x PD69012)
- ◆ Pre-Standard / Capacitor detection
- ◆ Detection of Cisco devices
- ◆ Supports both UART and I²C interfaces to the Host CPU
- ◆ Backwards compatible with the PD63000, PD62000 and PDIC66000
- ◆ Power Management for up to 96 ports
- ◆ Rmode pin for default parameters selection
- ◆ Programmable over-voltage and under voltage
- ◆ Pre-defined power budget – 16 discrete levels
- ◆ LED stream support
- ◆ System-OK indication
- ◆ Software download via I²C or UART
- ◆ System and port measurements
- ◆ Detailed port status
- ◆ Thermal protection and monitoring
- ◆ Programmable temperature alarm limit
- ◆ Interrupt out pin for system and port events
- ◆ Forced power for system testing
- ◆ System reset
- ◆ Port power limit setting
- ◆ Port matrix and priority
- ◆ Automatic PoE device type detection
- ◆ RoHS compliant

Ordering Information

Part Number	Disconnect	Detection	Version
PD69000xy-gggg	x = A: AC x = D: DC	y = R: Resistor y = C: Resistor/legacy	gggg*

*For the latest firmware version available, refer to Microsemi website or to customer care support.

Firmware Download

Initial burning of the controller's firmware is performed in the factory.

Firmware upgrades can be performed by the user using the communication interface (see Application Note 126 Cat No. 06-0006-080).

Applicable Documents

- ◆ IEEE 802.3af-2003 standard, DTE Power via MDI
- ◆ IEEE 802.3at-draft2.0
- ◆ Microsemi PD69012 Data Sheet, Cat. No. 06-0072-058
- ◆ Microsemi PD69008 Data Sheet, Cat. No. 06-0071-058
- ◆ Serial communication protocol User Guide 06-0032-056
- ◆ Microsemi Application Note 174 for Designing 48-port Enhanced PoE System (802.3af/802.3at Compliant), Cat. No. 06-0054-080
- ◆ Application Note 126: Software Download for PoE Units, Cat. No. 06-0006-080
- ◆ Freescale Semiconductor MC9S08GT60ACFB electrical characteristics

Package Information

The PD69000 is housed in a 44-pin QFP plastic package, 10 x 10 x 2 mm.

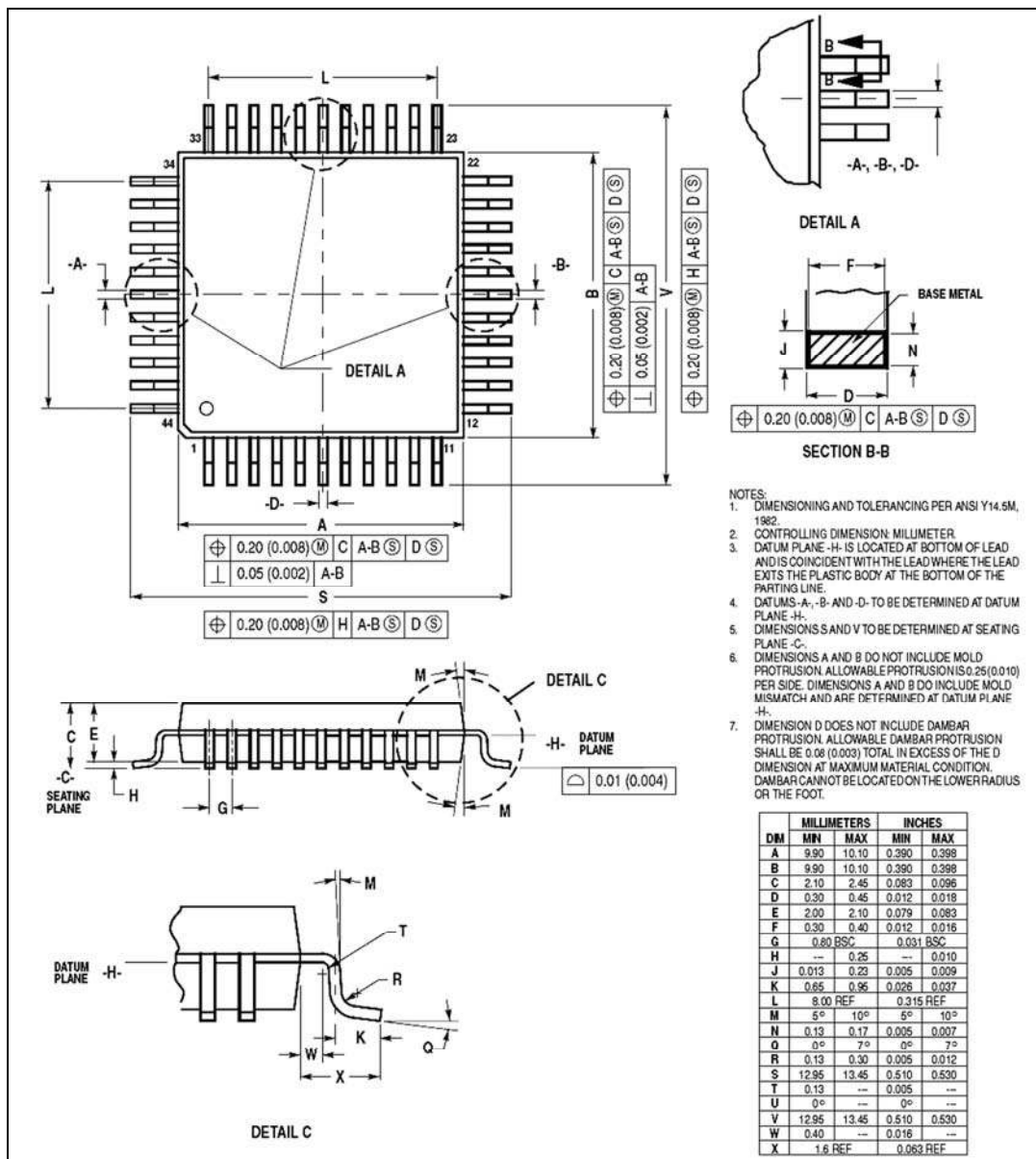

Pin Functionality

PIN	PIN NAME	PIN TYPE	PIN DESCRIPTION
1.	xReset_In	Digital input	Reset input
2.	Reserved	Digital output	
3.	Reserved	Digital output	
4.	SDA	Digital I/O	I2C data
5.	SCL	Digital input	I2C clock
6.	Self_reset	Digital output	Internal self Reset
7.	xLED_CS	Digital output	Chip select for LED stream
8.	xLED_Latch	Digital output	Latch for LED stream
9.	Tx	Digital output	UART transmit
10	Rx	Digital input	UART receive
11	Reserved	Digital output	
12	ESPI_xCS	Digital I/O	ESPI bus to PoE manager
13	ESPI_MISO	Digital I/O	ESPI bus to PoE manager
14	ESPI_MOSI	Digital I/O	ESPI bus to PoE manager
15	ESPI_SCK	Digital output	ESPI bus to PoE manager
16	VSS	Digital ground	Digital ground
17	VDD	Digital power	Main Supply 3.3v
18	Reserved	Digital I/O	Shorted to pin 20
19	xLED_OE	Digital I/O	Enable for status LED
20	Reserved	Digital I/O	Shorted to pin 18
21	LED0	Digital I/O	
22	Reserved	Digital I/O	

PIN	PIN NAME	PIN TYPE	PIN DESCRIPTION
23	HW_VER	A/D input	Hardware version
24	Reserved	A/D input	
25	I2C_ADDR	A/D input	I2C address of PD69000
26	Rmode	A/D input	N/A
27	xSystem_OK	Digital output	System validity indication
28	xHSWP	Digital I/O	N/A
29	xDisable_ports	Digital input	Disable all PoE Ports
30	VREFH	A/D ref. voltage	Reference high level
31	VREFL	A/D ref. voltage	Reference low level
32	xPoE_RESET	Digital output	Reset to PoE managers
33	xInt_Out	Digital output	Interrupt output indication
34	Reserved	Digital I/O	
35	Reserved	Digital I/O	
36	PG0	Digital input	Power Good #0
37	PG1	Digital input	Power Good #1
38	PG2	Digital input	Power Good #2
39	PG3	Digital input	Power Good #3
40	VDDAD	Analog power	Main Supply 3.3v
41	VSSAD	Analog ground	Analog ground
42	BKGD	Digital I/O	BDM burn-in
43	XTAL	Analog output	Oscillator output
44	EXTAL	Analog input	Oscillator input

Electrical Specification

Comment: For detailed electrical specification refer to the following datasheets (at: www.freescale.com)

- Manufacturer - Freescale Semiconductor
- Manufacturer part number - MC9S08GT60A

Main Features Description

Function	Description
Supports up to eight PoE devices, 96 ports	The PoE devices can be cascaded for up to eight PoE devices, that will fit into a 96 ports PoE system utilizing one PoE Controller (PD69000)
Power management	The system supports two power management modes: Class mode, Dynamic mode and static mode. See Technical Note 113, Cat. No. 06-0002-081 for more details.
Threshold configuration	Over-voltage and under-voltage thresholds configuration for disconnection purposes.
High Power ports	The PoE devices can be configured (both hardware and software) so as to enable higher current through ports (up to ~720mA)
Communication	Supports both I ² C and UART interfaces with Host CPU.
Legacy (capacitor) detection	Allows detection and powering of pre-standard devices (PDs).
LED stream	Direct SPI interface to an external LED Stream circuitry. It allows the designer to implement a simple LED circuit that does not require a software code.
System OK indication	Digital output pin to the Host, indicating that voltage and temperature range are valid.
System and port measurements	Measurements of the following parameters: Current (mA), Power consumption (W), Vmain (V), Port voltage (V), Class of PD (0-4).
Detailed port status	Port statuses are received from PoE managers such as: port on, port off due to disconnection or due to overload
Interrupt pin	Interrupt out from the PoE Controller indicating events such as: Port On, Port Off, Port Fault, PoE device Fault, Voltage out of range and more. For a full list of interrupt events, refer to Serial Communication Protocol, Cat. No. 06-0032-056.
Port power limit	Configurable Port power limit; when a port exceeds power limit, it is automatically disconnected
Power matrix control	Allows the layout designer to connect all physical ports to the logical ports whenever desired.
'Power Good' interrupt from power supply	For systems comprising more than a single power supply, a fast port disconnection mechanism is executed in cases where one power supply fails, in order to maintain operation and prevent collapse of the other power supplies.

I²C Address Selection

I²C interface between the Host CPU and a specific PD69000 requires the setting of address for the device; this is done by applying a specific voltage level to pin#25 (I2C_ADDR) as shown below:

I2C_ADDR Voltage Level	I ² C Address (hexadecimal)
0.00 to 0.21 V	UART
0.21 to 0.41 V	0x4
0.41 to 0.62 V	0x8
0.62 to 0.83 V	0xC
0.83 to 1.03 V	0x10
1.03 to 1.24 V	0x14
1.24 to 1.44 V	0x18
1.44 to 1.65 V	0x1C
1.65 to 1.86 V	0x20
1.86 to 2.06 V	0x24
2.06 to 2.27 V	0x28
2.27 to 2.48 V	0x2C
2.48 to 2.68 V	0x30
2.68 to 2.89 V	0x34
2.89 to 3.09 V	0x38
3.09 to 3.30 V	0x3C

The information contained in the document is PROPRIETARY AND CONFIDENTIAL information of Microsemi and cannot be copied, published, uploaded, posted, transmitted, distributed or disclosed or used without the express duly signed written consent of Microsemi. If the recipient of this document has entered into a disclosure agreement with Microsemi, then the terms of such Agreement will also apply. This document and the information contained herein may not be modified, by any person other than authorized personnel of Microsemi. No license under any patent, copyright, trade secret or other intellectual property right is granted to or conferred upon you by disclosure or delivery of the information, either expressly, by implication, inducement, estoppel or otherwise. Any license under such intellectual property rights must be approved by Microsemi in writing signed by an officer of Microsemi. Microsemi reserves the right to change the configuration, functionality and performance of its products at anytime without any notice. This product has been subject to limited testing and should not be used in conjunction with life-support or other mission-critical equipment or applications. Microsemi assumes no liability whatsoever, and Microsemi disclaims any express or implied warranty, relating to sale and/or use of Microsemi products including liability or warranties relating to fitness for a particular purpose, merchantability, or infringement of any patent, copyright or other intellectual property right. The product is subject to other terms and conditions which can be located on the web at <http://www.microsemi.com/legal/tnc.asp>

Revision History

Revision Level / Date	Para. Affected	Description
1.0 31/ August.08		Initial release
1.1 22/ January.09	P3	Comment added
1.1 27 Jul 10		Changing catalog numbers metrology

© 2009 Microsemi LTD.
All rights reserved.

For support contact: sales_AMSG@microsemi.com

Visit our web site at: www.microsemi.com

Cat. No. DS_PD69000