



American Opto Plus LED Corp.

L944MURC-45D

3.9 x 3.9 x 3.0mm Hype Red High Power LED

PACKAGE OUTLINES

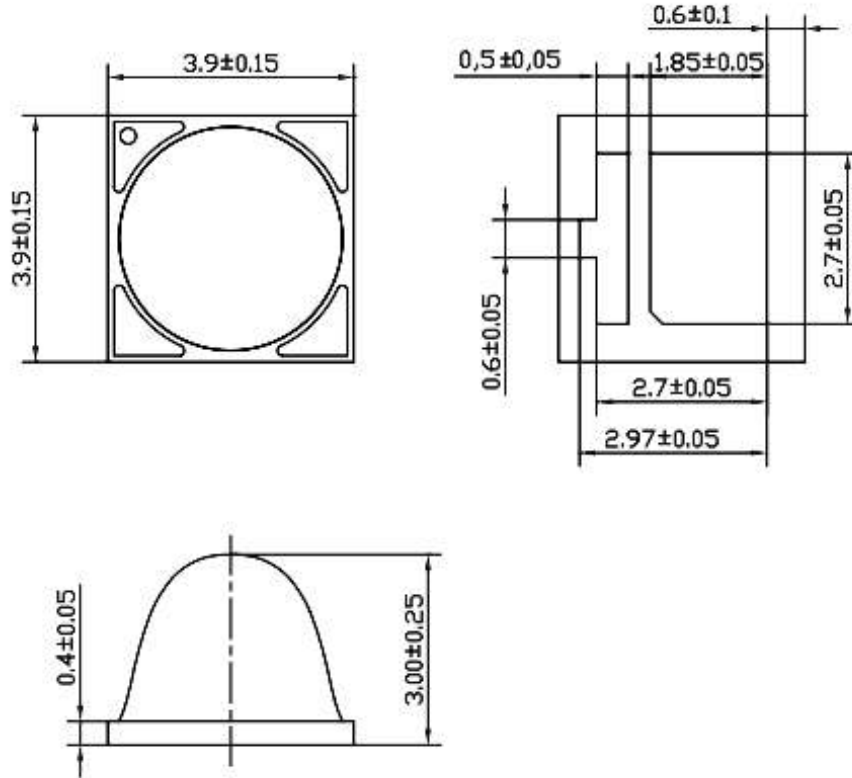

FEATURES

1. Dimensions: 3.9mm(L)×3.9mm(W).
2. High Radiant Flux type.
3. All Metal Design Cu Substrate with Silicone Lens.
4. Exceed narrow beam angle 45°.
5. Ultra-low thermal resistance.
6. MSL Level: 3.

Note:

1. Units are in millimeters.



American Opto Plus LED Corp.
L944MURC-45D
3.9 x 3.9 x 3.0mm Hype Red High Power LED

PAD CONFIGURATION

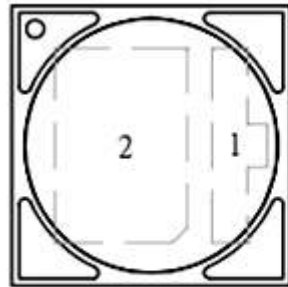

TOP

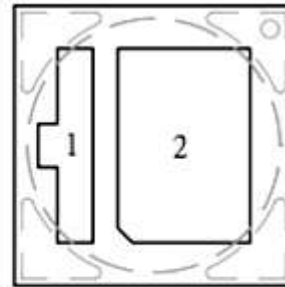

BOTTOM

Pad	Function
1	Cathode
2	Anode, Thermal

Note:

1. Please do not put conductive material on the top surface of the LEDs.



American Opto Plus LED Corp.

L944MURC-45D

3.9 x 3.9 x 3.0mm Hype Red High Power LED

ABSOLUTE MAXIMUM RATINGS

T_j=25°C

Parameter	Symbol	Rating	Unit
Power Dissipation	P	3	W
Forward Current	I _F	1000	mA
Forward Pulse Current	I _{FP}	1400	mA
Thermal Resistance, Junction Case	R _{th, J-C1}	3	°C/W
Reverse Voltage	V _R	5	V
LED Junction Temperature	T _j	125	°C
Operating Temp. Range	T _{opr}	-40°C~+80°C	
Storage Temp. Range	T _{stg}	-40°C~+120°C	
Soldering Condition	T _{sol}	260°C for 5 sec.	

Forward Pulse Current (1/10 Duty Cycle, 400msec Pulse Width).

The thermal resistance value is measured with MCPCB (star).

ELECTRICAL/OPTICAL CHARACTERISTICS (Deep Red)

T_j=25°C

Parameter	Symbol	Min	Typ	Max	Test Condition	Unit
Forward Voltage	V _F	2.07	2.4	3.03	I _F =700mA	V
Reverse Current	I _R	--	--	100	V _R =5V	μA
Radiant Flux	Φ _e	700	900	--	I _F =700mA	mW
Peak Wavelength	λ _p	650	--	670		nm



American Opto Plus LED Corp.
L944MURC-45D
3.9 x 3.9 x 3.0mm Hype Red High Power LED

RADIATION PATTERN

Typical Representative Spatial Radiation Pattern

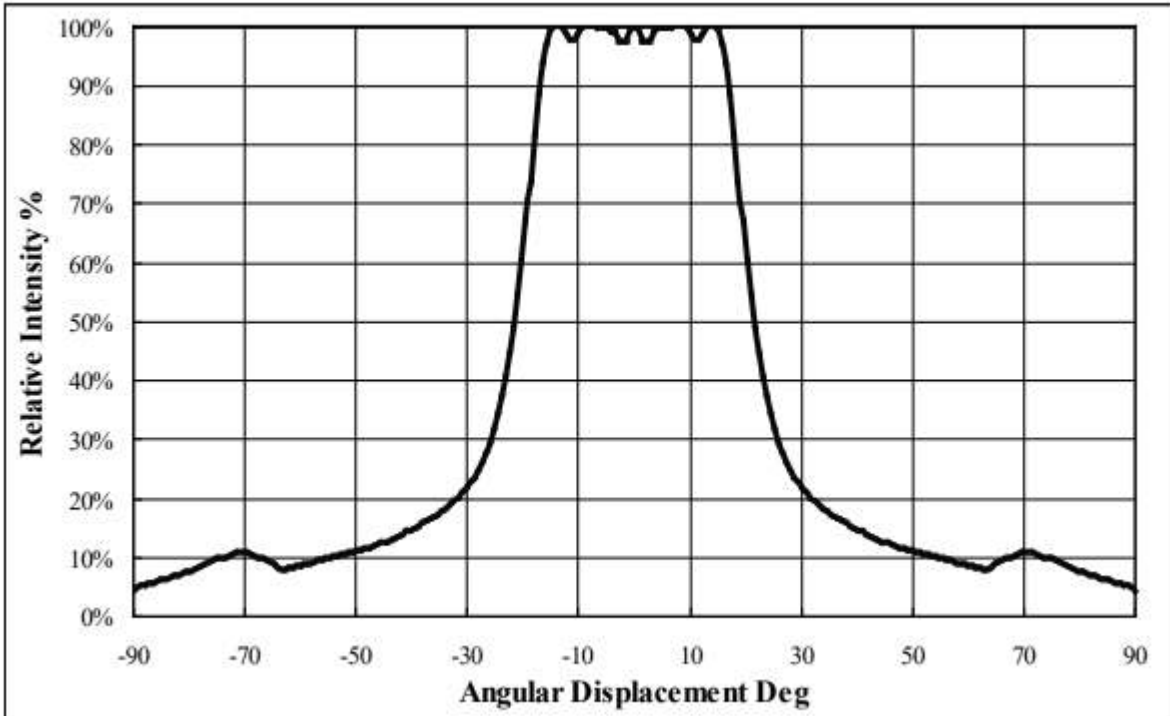



American Opto Plus LED Corp.
L944MURC-45D
3.9 x 3.9 x 3.0mm Hype Red High Power LED

BIN CODE LIST

T_j=25°C

Item	Bin Code	Symbol	Condition	Min	Max	Unit
Forward Voltage	D	V _F	IF=700mA	2.07	2.31	V
	E			2.31	2.55	
	F			2.55	2.79	
	G			2.79	3.03	
Radiant Flux	H	Φ _e	IF=700mA	700	800	mW
	J			800	900	
	K			900	1000	
	L			1000	1200	

Forward voltage measurement allowance is ± 0.1V.

Luminous flux measurement allowance is ± 10%.



American Opto Plus LED Corp.

L944MURC-45D

3.9 x 3.9 x 3.0mm Hype Red High Power LED

CHARACTERISTIC DIAGRAMS

Forward Current vs. Forward Voltage

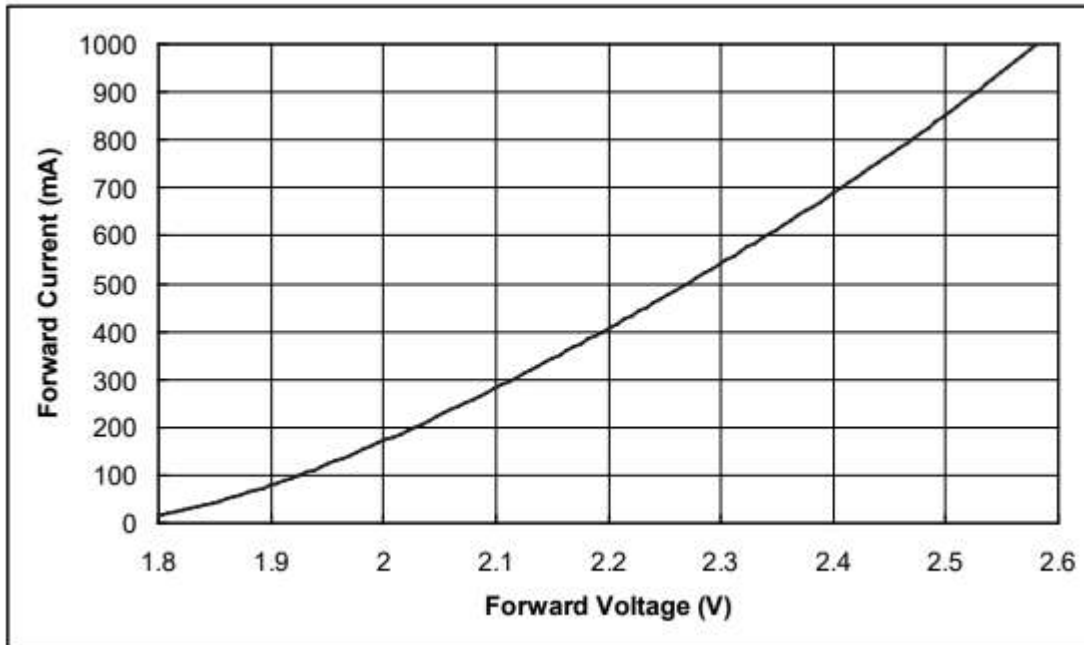

Relative Intensity vs. Forward Current

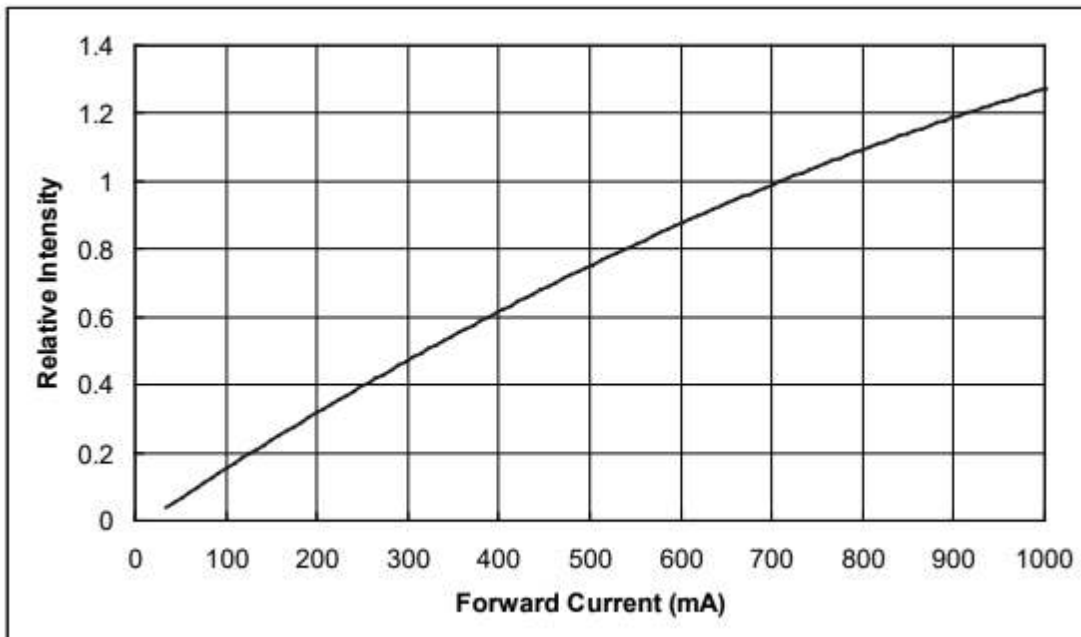



American Opto Plus LED Corp.
L944MURC-45D
3.9 x 3.9 x 3.0mm Hype Red High Power LED

CHARACTERISTIC DIAGRAM

Relative Intensity vs. Wavelength

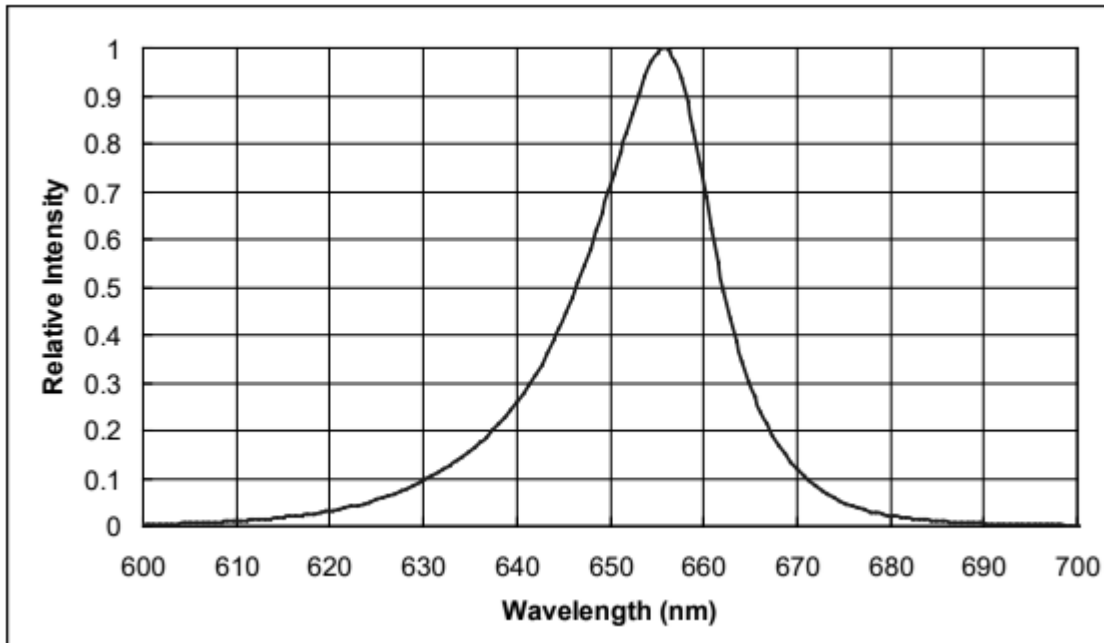



American Opto Plus LED Corp.

L944MURC-45D

3.9 x 3.9 x 3.0mm Hype Red High Power LED

PACKAGING SPECIFICATIONS

Taping Dimension

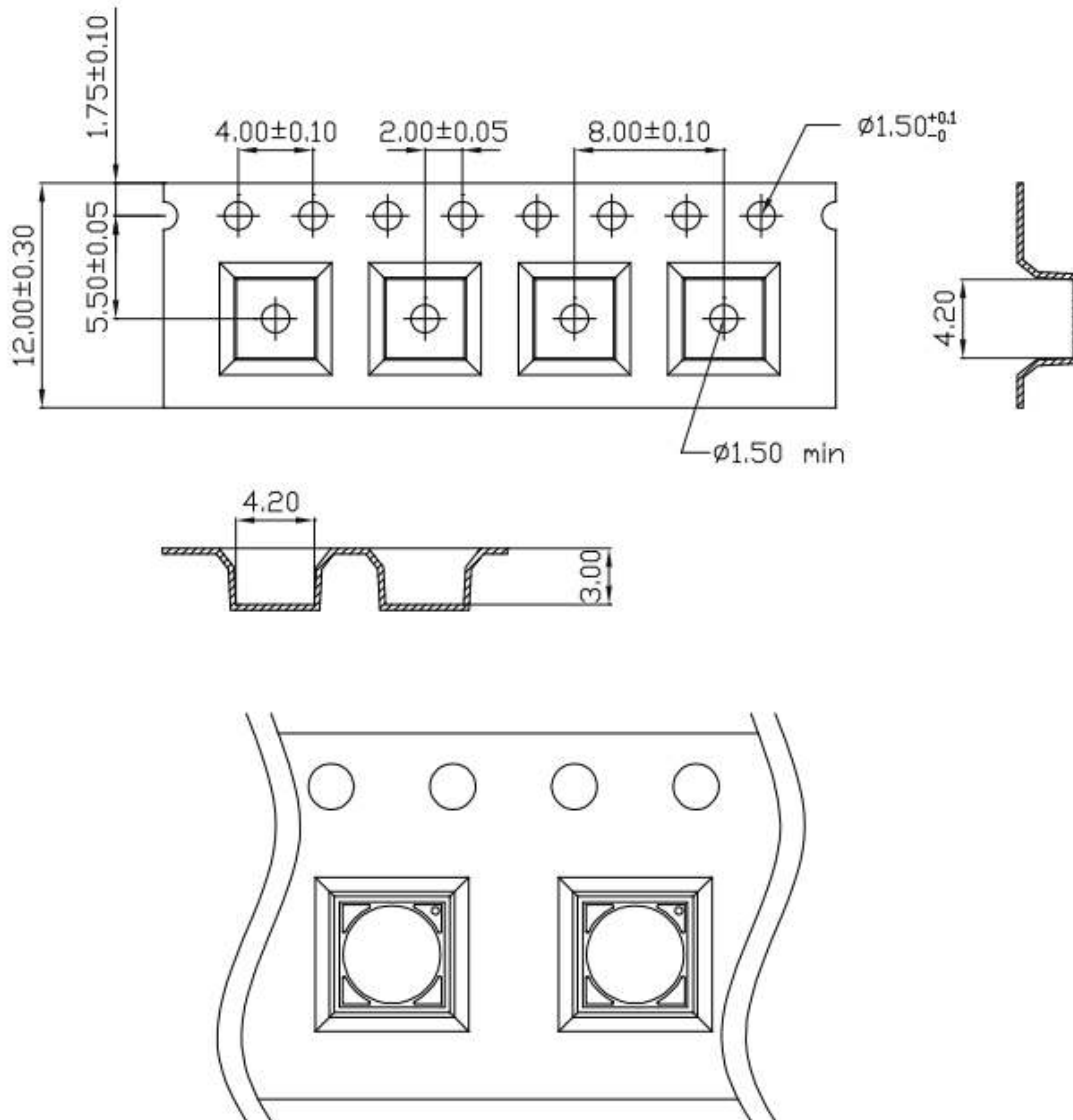

Note:

1. Moisture proof bag.
2. 1 Reel/bag.
3. 2500 pcs/reel.
- 4 Units are in millimeters.



American Opto Plus LED Corp.

L944MURC-45D

3.9 x 3.9 x 3.0mm Hype Red High Power LED

PACKAGING SPECIFICATIONS

Reel Dimensions (Unit: mm)

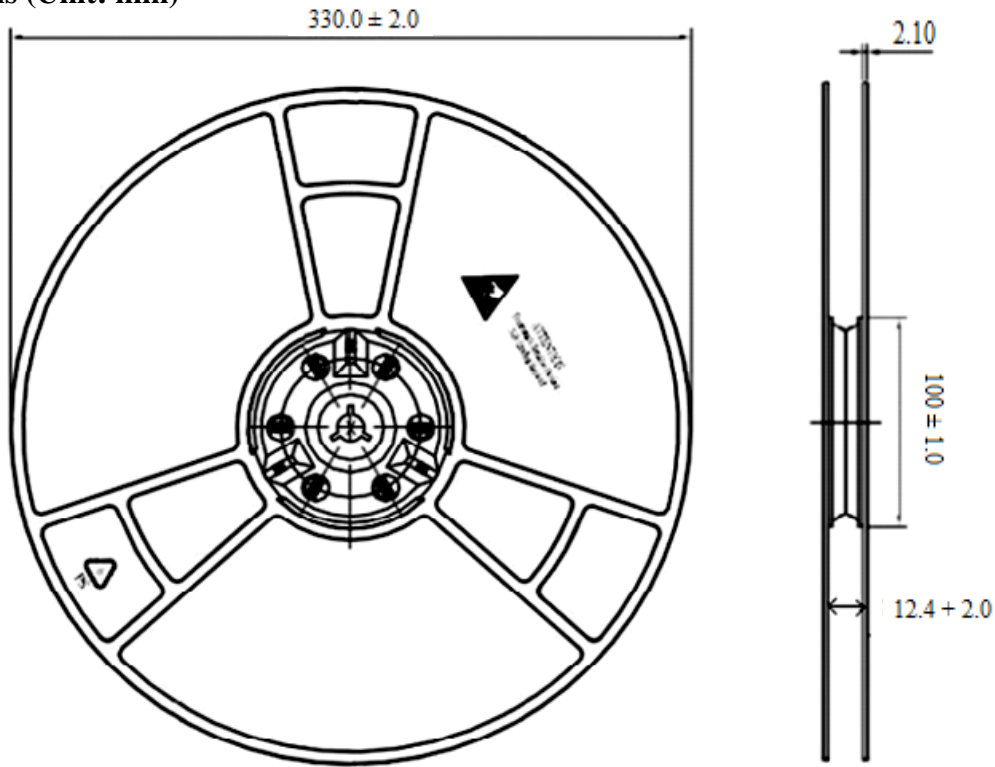

Anti-Statistic Bag (Unit: mm)

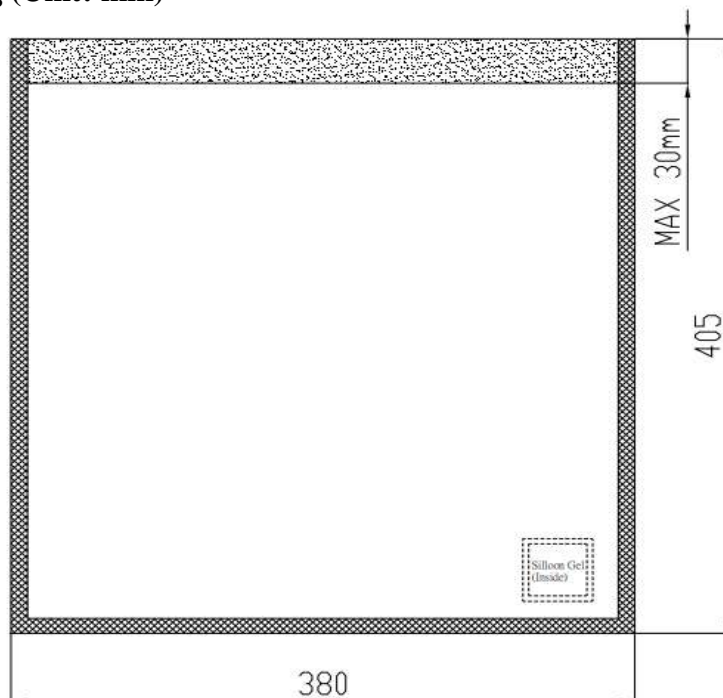



American Opto Plus LED Corp.

L944MURC-45D

3.9 x 3.9 x 3.0mm Hype Red High Power LED

QUALIFICATION RELIABILITY TEST

Classification	Test Item	Test Conditions	Reference Standard
Endurance Test	Operation Life	IF = 700mA Ta = 25°C Test Duration = 1000hrs	MIL – STD – 750: 1026 MIL – STD – 883: 1005 JIS C 7021: B-1
	High Temp. High Humidity Storage	Ta = 85 ± 5°C RH = 85 ± 5% Test Duration = 1000hrs	MIL – STD – 202: 103B JIS C 7021: B-11
	High Temperature Storage	Ta = 105 ± 5°C Test Duration = 1000hrs	MIL – STD – 202: 1008 JIS C 7021: B-10
	Low Temperature Storage	Ta = -40 ± 5°C Test Duration = 1000hrs	JIS C 7021: B-12
Environmental Test	Temperature Cycling	-30°C ~ 25°C ~ 105°C ~ 25°C 30min – 5min – 30min – 5 min Test Duration = 10 cycles	MIL-STD-202: 107D MIL-STD-750: 1051 MIL-STD-883: 1010 JIS C 7021: A-4
	Thermal Shock	-30 ± 5°C ~ 105 ± 5°C 30min ~ 30min Test Duration = 10 cycles	MIL-STD-202: 107D MIL-STD-750: 1051 MIL-STD-883: 1011
	Solder Resistance	Tsol = 260 ± 5°C Dwell Time: 10 sec	MIL-STD-202: 210A MIL-STD-750: 2031 JIS C 7021: A-1



American Opto Plus LED Corp.
L944MURC-45D
3.9 x 3.9 x 3.0mm Hype Red High Power LED

RELIABILITY TESTING

Measuring Items	Symbol	Measuring Conditions	Failure Criteria
Forward Voltage	VF	IF=700mA	VF shift > 10%
Luminous	Iv%	IF=700mA	Iv% shift > 10%



American Opto Plus LED Corp.

L944MURC-45D

3.9 x 3.9 x 3.0mm Hype Red High Power LED

RECOMMENDED SOLDER PROFILE

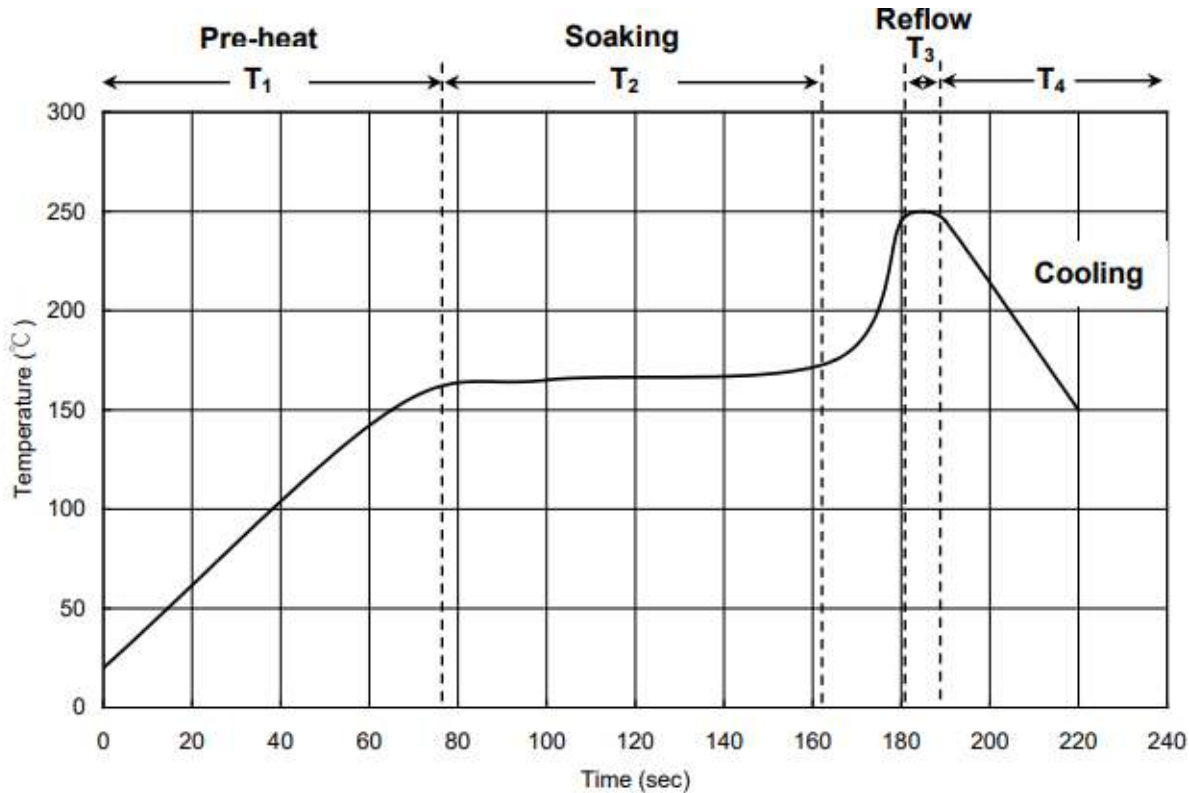

	Parameter	Values
T1	Ramp Up Rate	1.0 ~ 3.0 °C/sec
	Pre-heat Time	50 ~ 80 sec
T2	Soaking Temperature	155 ~ 185 °C
	Dwell Time During Soaking	60 ~ 120 sec
T3	Reflow Temperature	240 ~ 250 °C
	Reflow Time	Max 10 sec
	Ramp Up Rate During Reflow	1.2 ~ 2.3 °C/sec
T4	Cooling	1.0 ~ 6.0 °C/sec

Suggest using Sn96Ag3Cu 0.5 lead free solder.

Cleaning: Use alcohol – based cleaning solvents such as isopropyl alcohol to clean the LED if necessary.



American Opto Plus LED Corp.

L944MURC-45D

3.9 x 3.9 x 3.0mm Hype Red High Power LED

RECOMMENDED SOLDER PATTERN

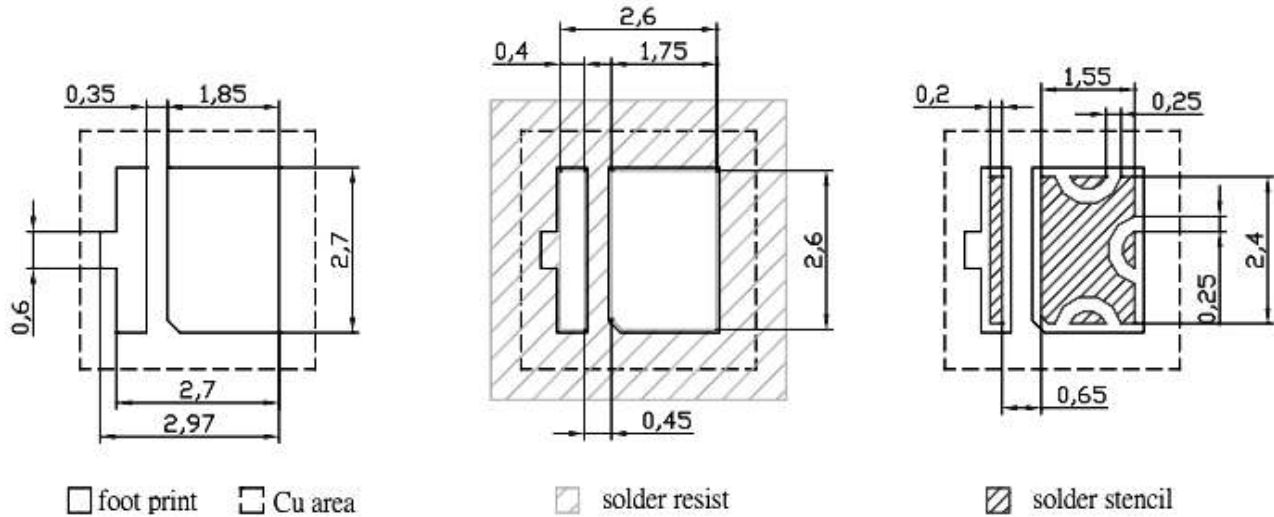

Note:

1. Unit in millimeters.
2. Tolerance is ± 0.05 .



American Opto Plus LED Corp.

L944MURC-45D

3.9 x 3.9 x 3.0mm Hype Red High Power LED

HANDLING PRECAUTIONS



Do not poke the silicone encapsulant with sharp object



Do not stack assembled PCB



Do not hold the LED with hand



Do not touch and press the silicone encapsulant

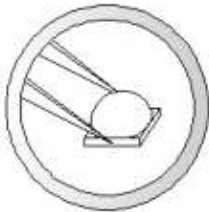

Hold the LED only by the metal substrate



Clean the silicone surface with cotton bud with minimal pressure



Use pick and place nozzle per recommendation in datasheet