

REVISIONS			
REV	DESCRIPTION, ECN, EAR NO.	DATE	APP'D
A	PROPOSAL	JUL03/13	L.CHAN
B	ADD OPERATING TEMPERATURE	FEB08/14	L.CHAN
C	ADD PACKAGING INFORMATION	APR11/14	L.CHAN
D	ADD DIMENSION FOR PIN LENGTH	MAY25/16	L.CHAN
E	ADD DIMENSION FOR PIN AND POST	JUL21/16	L.CHAN
F	ADD DIMENSION FOR PIN AND POST	JUL22/16	L.CHAN
G	FIX ERROR	MAY31/18	L.CHAN

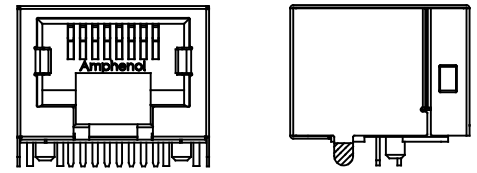

SHOWING FOR RJE73-188-00X00
(WITHOUT SHIELD TABS)

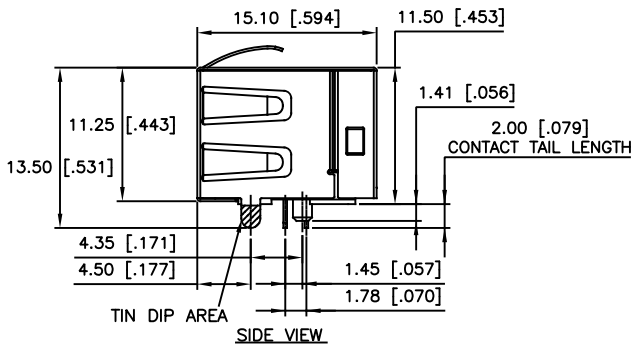
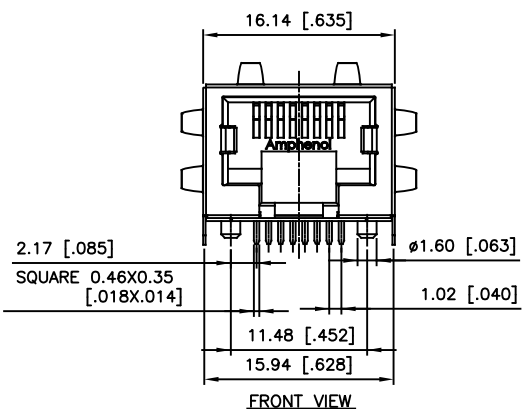
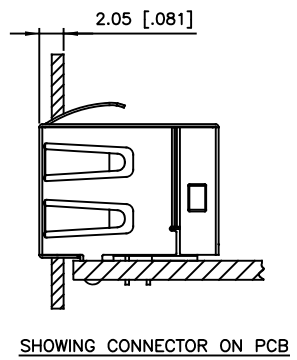
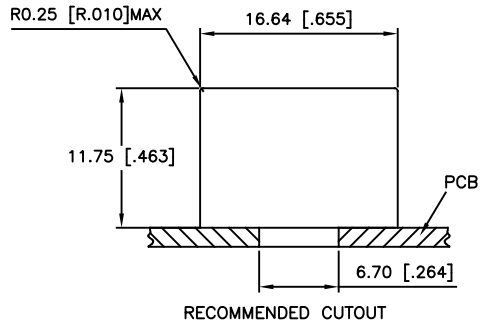

SHOWING CONNECTOR ON PCB

- 1. MATERIALS:**
 PLASTIC HOUSING: HIGH TEMPERATURE THERMOPLASTIC
 FLAMMABILITY RATING UL 94V-0
 COLOUR: BLACK
- CONTACTS:** PHOSPHOR BRONZE
 PLATING: SELECTIVE GOLD PLATING ON MATING SURFACES
 SEE AMPHENOL PART NUMBER FOR DETAIL.
 50 μ" [1.27 MICRONS]
 MIN. NICKEL UNDERPLATE
 100 μ" [2.54 MICRONS]
 MIN. TIN ON CONTACT TAILS.
- SHIELD:** STAINLESS STEEL WITH TIN DIP ON SOLDER TAIL
- MATES WITH MODULAR PLUG CONFORMING TO FCC PART 68, SUBPART F.**
- RECOMMENDED SOLDER PROCESS:** WAVE SOLDER, PEAK TEMPERATURE 260° FOR 8~10 SECOND.

- AMPHENOL PART NUMBER: RJE73-188-00X0X
- GOLD PLATING OPTION
 1=6u" GOLD PLATING
 2=15u" GOLD PLATING
 3=30u" GOLD PLATING
 4=50u" GOLD PLATING
- GROUND TABS OPTION
 0=WITHOUT TAB
 1=WITH SIDE AND TOP TABS

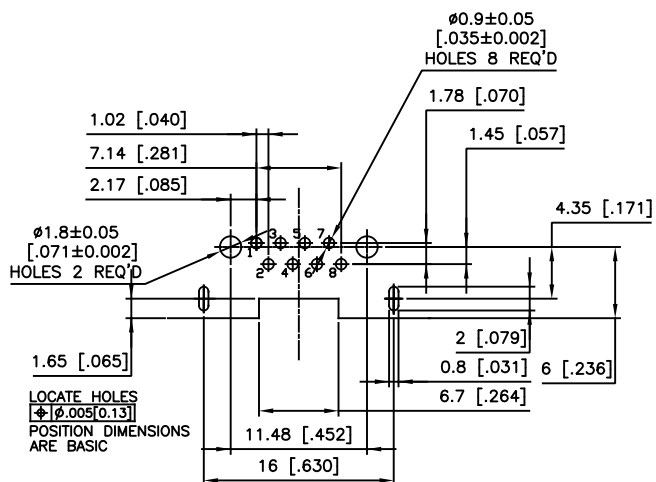

RECOMMENDED P.C.B. LAYOUT
(COMPONENT SIDE OF BOARD)
TOLERANCES: +/- 0.05[.002]



UNLESS SPECIFIED OTHERWISE		DRAWN GAVIN.H	DATE JUL03/13	Amphenol Canada Corp. Commercial Products
PRIMARY UNITS MILLIMETER	CHECKED LAWRENCE.C	JUL03/13	TITLE	
SECONDARY INCH	M.E. APP'D		MODULAR JACK, 8 POSITIONS, 8 CONTACTS, SHIELDED, NO LEDS, WITH TAPE & REEL PACKAGING -RoHS COMPLIANT	
REFERENCE IN PARENTHESES	Q.A. APP'D		DWG. NO.	
GENERAL TOLERANCES	DWG APPR.		P-RJE73-188-00X0X	
1 DECIMAL PLACE ±0.35	ENG. REL. NO.		REV G	
2 DECIMAL PLACES ±0.30	REF.		CODE ID NO. 03554 DWG SIZE: C SCALE: N/A SHEET 1 OF 2	
3 DECIMAL PLACES ±0.20	THIRD ANGLE PROJECTION			
ANGULAR DEGREES ±1.0°	DO NOT SCALE DRAWING			

THIS DOCUMENT CONTAINS PROPRIETARY INFORMATION AND SUCH INFORMATION MAY NOT BE DISCLOSED TO OTHERS FOR ANY PURPOSE OR USED FOR MANUFACTURING PURPOSES WITHOUT WRITTEN PERMISSION FROM AMPHENOL CANADA CORP.

REVISIONS				
REV	DESCRIPTION, ECN, EAR NO.	DATE	APP'D	
A	PROPOSAL	JUL03/13	L.CHAN	
B	ADD OPERATING TEMPERATURE	FEB08/14	L.CHAN	
C	ADD PACKAGING INFORMATION	APR11/14	L.CHAN	
D	ADD DIMENSION FOR PIN LENGTH	MAY25/16	L.CHAN	
E	ADD DIMENSION FOR PIN AND POST	JUL21/16	L.CHAN	
F	ADD DIMENSION FOR PIN AND POST	JUL22/16	L.CHAN	
G	FIX ERROR	MAY31/18	L.CHAN	

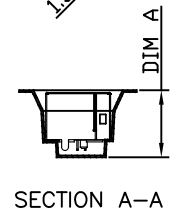
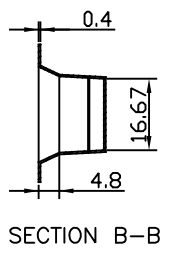
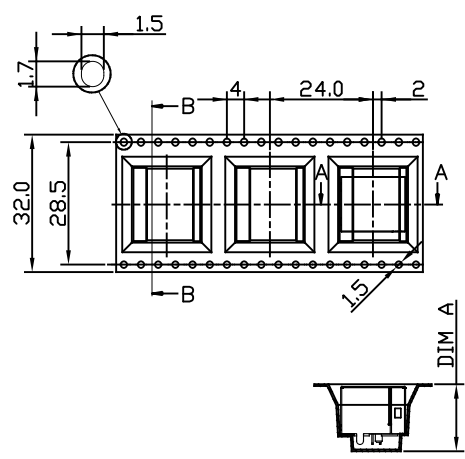

← DIRECTION OF CONNECTOR LOADED INTO MACHINE

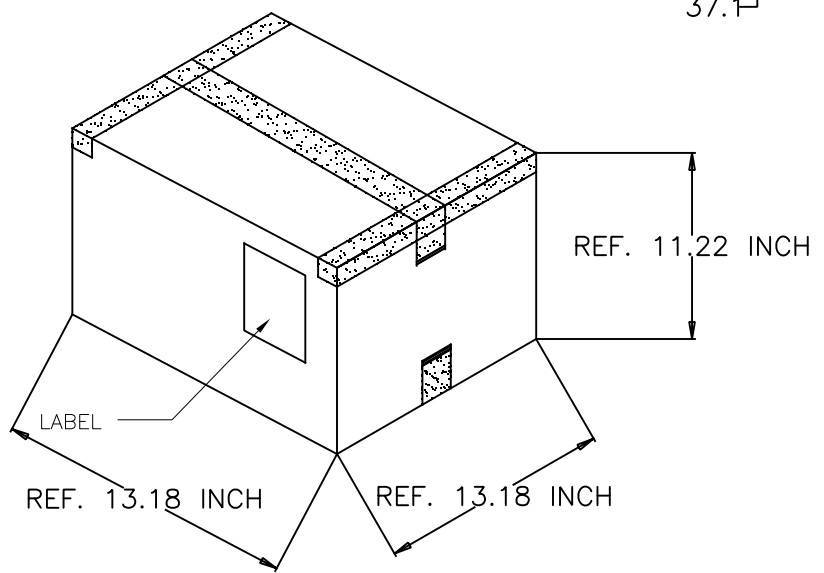
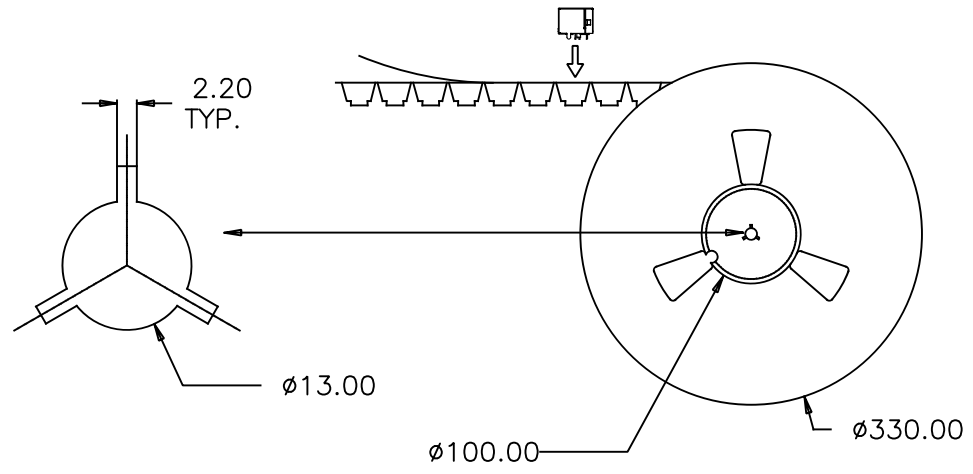
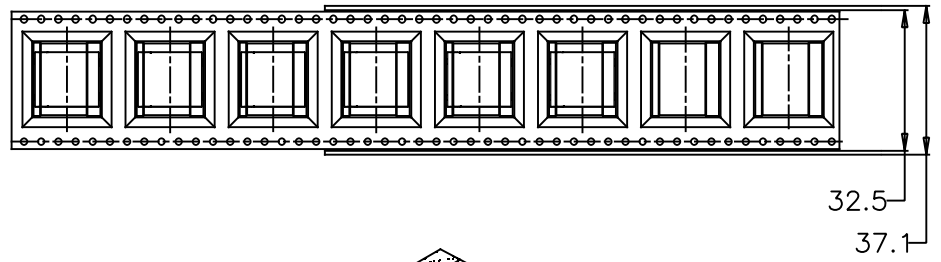

PACKAGING NOTES:

1. 8 EMPTY CAVITIES FOR TAPE LEADER AND 15 EMPTY CAVITIES FOR TAPE TRAILER.
2. A FULLY LOADED CARTON SHOULD CONTAIN 7 REELS OF CONNECTOR.



RJE73-188-00X00	WITHOUT TAB	180PCS	1260PCS	15.18mm
RJE73-188-00X01	WITH TABS	160PCS	1120PCS	16.02mm
AMPHENOL PART NUMBER	TAB OPTION	QUANTITY PER REEL	QUANTITY PER CARTON	DIM A

UNLESS SPECIFIED OTHERWISE	DRAWN GAVIN.H	DATE JUL03/13
PRIMARY UNITS INCH	CHECKED LAWRENCE.C	DATE JUL03/13
SECONDARY MILLIMETER	M.E. APP'D	
REFERENCE IN PARENTHESES	Q.A. APP'D	
GENERAL TOLERANCES	DWG APPR.	
1 DECIMAL PLACE ±0.35	ENG. REL. NO.	
2 DECIMAL PLACES ±0.30	REF.	
3 DECIMAL PLACES ±0.20		
ANGULAR DEGREES ±1.0°		
THIRD ANGLE PROJECTION	DO NOT SCALE DRAWING	

Amphenol Canada Corp.
Commercial Products

TITLE: MODULAR JACK, 8 POSITIONS, 8 CONTACTS, SHIELDED, NO LEDS, WITH TAPE & REEL PACKAGING -RoHS COMPLIANT

DWG. NO. P-RJE73-188-00X0X REV G

CODE ID NO. 03554 DWG SIZE: c SCALE: N/A SHEET 2 OF 2

REVISIONS				
REV	DESCRIPTION, ECN, EAR NO.	DATE	APP'D	
A	PROPOSAL	JUL03/13	L.CHAN	
B	ADD OPERATING TEMPERATURE	FEB08/14	L.CHAN	
C	ADD PACKAGING INFORMATION	APR11/14	L.CHAN	
D	ADD DIMENSION FOR PIN LENGTH	MAY25/16	L.CHAN	
E	ADD DIMENSION FOR PIN AND POST	JUL21/16	L.CHAN	
F	ADD DIMENSION FOR PIN AND POST	JUL22/16	L.CHAN	
G	FIX ERROR	MAY31/18	L.CHAN	

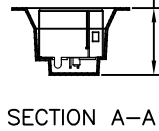
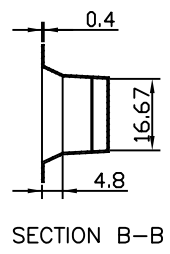
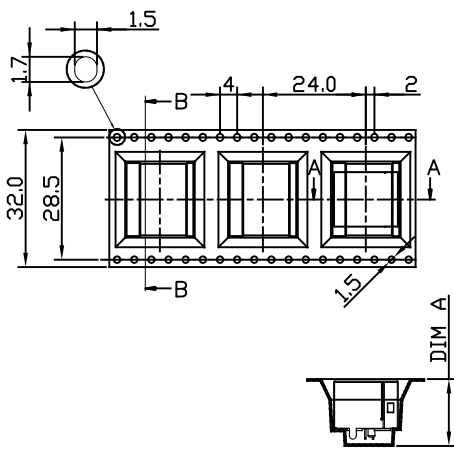

← DIRECTION OF CONNECTOR LOADED INTO MACHINE

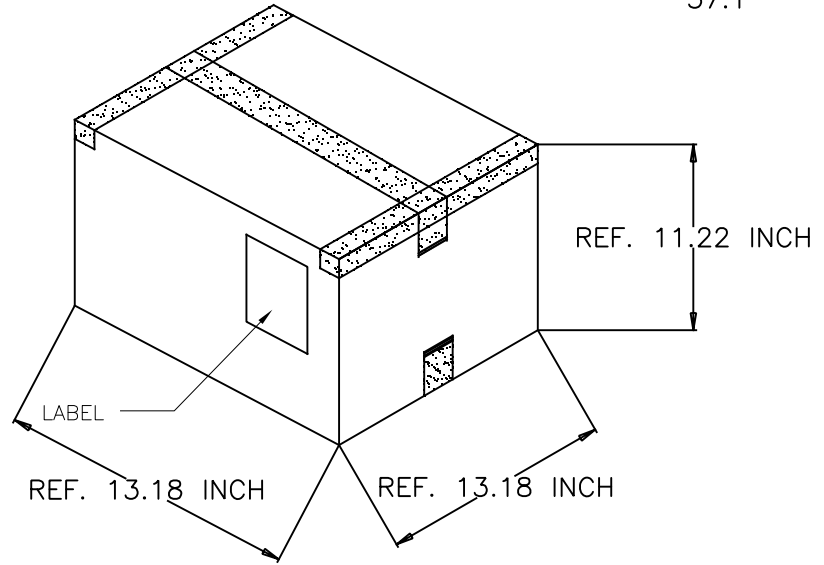
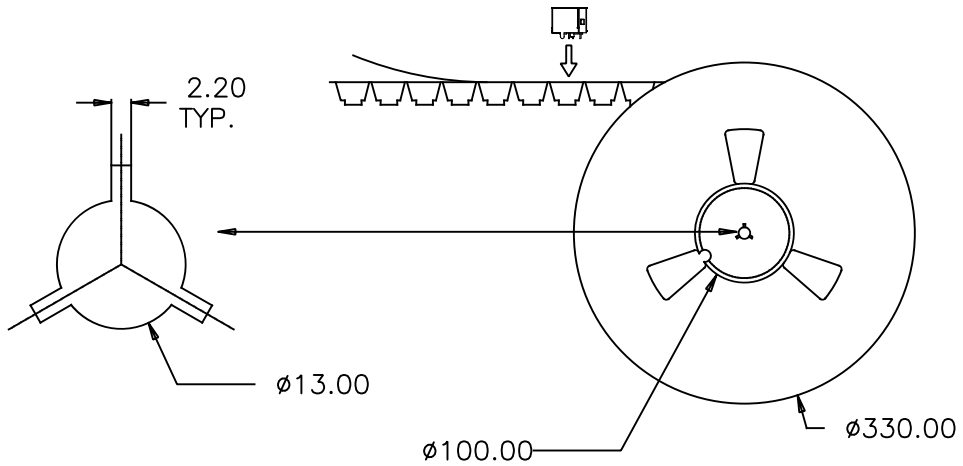
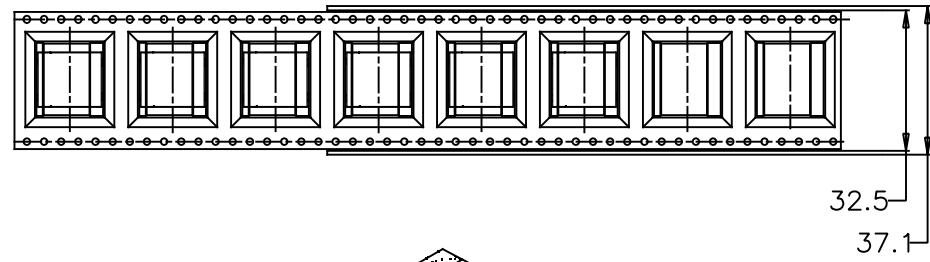

PACKAGING NOTES:

1. 8 EMPTY CAVITIES FOR TAPE LEADER AND 15 EMPTY CAVITIES FOR TAPE TRAILER.
2. A FULLY LOADED CARTON SHOULD CONTAIN 7 REELS OF CONNECTOR.



RJE73-188-00X00	WITHOUT TAB	180PCS	1260PCS	15.18mm
RJE73-188-00XX1	WITH TABS	160PCS	1120PCS	16.02mm
AMPHENOL PART NUMBER	TAB OPTION	QUANTITY PER REEL	QUANTITY PER CARTON	DIM A

UNLESS SPECIFIED OTHERWISE	DRAWN GAVIN. H	DATE JUL03/13	Amphenol Canada Corp.	
PRIMARY UNITS INCH	CHECKED LAWRENCE.C	DATE JUL03/13	Commercial Products	
SECONDARY MILLIMETER	M.E. APP'D	Q.A. APP'D	TITLE	
REFERENCE IN PARENTHESES	DWG APPR.	ENG. REL. NO.	MODULAR JACK, 8 POSITIONS, 8 CONTACTS, SHIELDED, NO LEDS, WITH TAPE & REEL PACKAGING -RoHS COMPLIANT	
GENERAL TOLERANCES	REF.	THIRD ANGLE PROJECTION	DWG. NO. P-RJE73-188-00X0X	REV G
1 DECIMAL PLACE ±0.35		DO NOT SCALE DRAWING	CODE ID NO. 03554	DWG SIZE: C
2 DECIMAL PLACES ±0.30			SCALE: N/A	SHEET 2 OF 2
3 DECIMAL PLACES ±0.20				
ANGULAR DEGREES ±1.0°				