

REV.	DESCRIPTION	DATE	APPROVED
<b>A</b>	Engineering Release	<b>04/10/03</b>	<b>M. C.</b>
<b>B</b>	Engineering Update w/o Changes	<b>01/28/05</b>	<b>M. C.</b>
<b>C</b>	Removed Material Code	<b>05/23/16</b>	<b>J. C.</b>

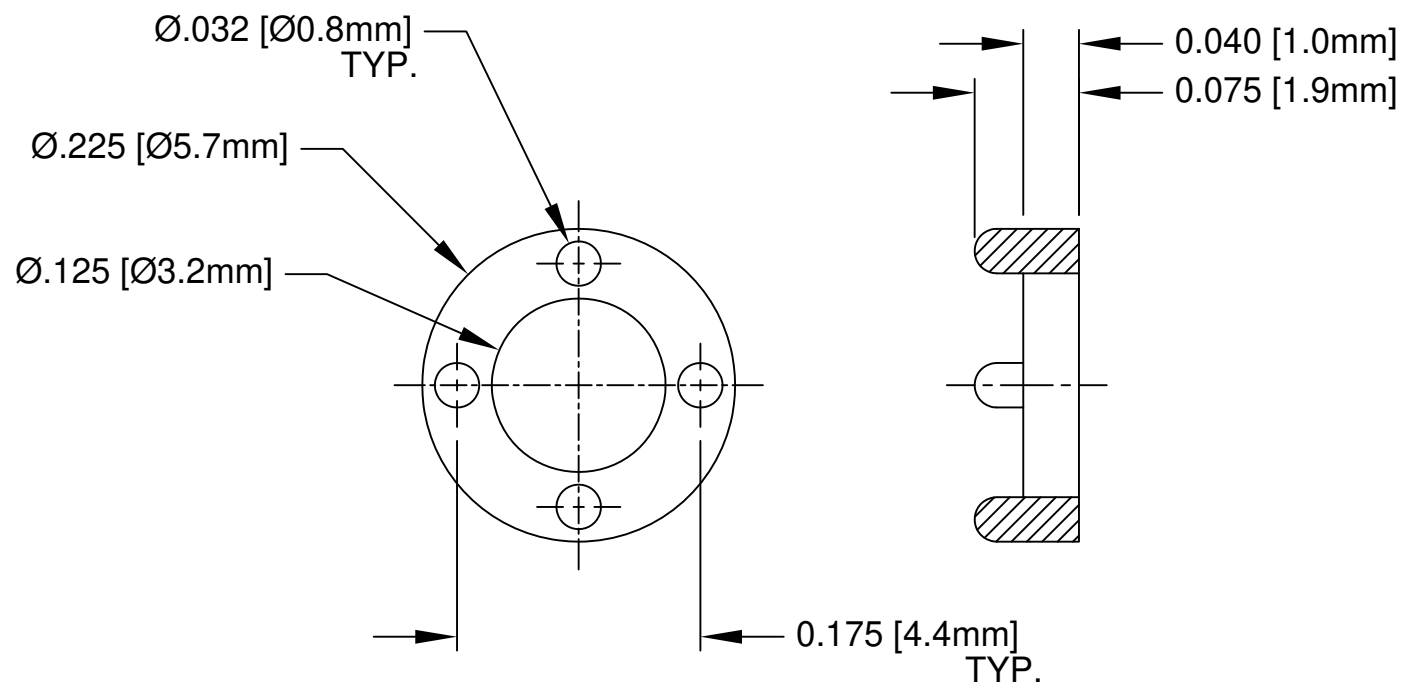

- 2. MATERIAL: NYLON 6/6, 94V-2, WHITE.
- 1. GENERAL SPECIFICATIONS: BIVAR MOLDED COMPONENT SPECIFICATION BV00-E101.

STANDARD TOLERANCE ( UNLESS OTHERWISE SPECIFIED ) DECIMALS                      ANGULAR .X            ± .1                      X°    ± 1° .XX          ± .01 .XXX        ± .005			
		4 THOMAS, IRVINE, CA. 92618 TEL.: (949) 951-8808    FAX: (949) 951-3974	
		<b>TITLE:</b> PERM-O-PAD LED MOUNT	
<b>DESIGNED:</b> <b>D. Green</b>	<b>DATE:</b> <b>04/10/03</b>	<b>PART NO:</b> 103-080	<b>REVISION:</b> <b>C</b>
<b>CHECKED:</b> <b>M. Chen</b>	<b>DATE:</b> <b>04/10/03</b>	<b>CAGE CODE :</b> 32559	<b>SHEET #</b> 1 <b>OF</b> 1
<small>CAD GENERATED DOCUMENT. DO NOT MEASURE DRAWING.</small>			